

NOTES:

- △
- △
- △
- △

REV.	REVISIONS
A	
B	

S. R. 54-3585

ECO 7748  
EXT CHANGES  
SEE ECO 7748

1/19/70

**HONEYWELL**  
INC  
COMPUTER CONTROL DIVISION  
Old Connecticut Path, Framingham, Mass

DR. D. HAMEL  
ENG. K. IZBICKI  
APP.

DATE  
11-26-68  
7-8-69

TITLE	H-316
	COLUMN No. 1
SIZE	DWG NO.
C	70024485
REV.	B

PROJECT NO. 55202

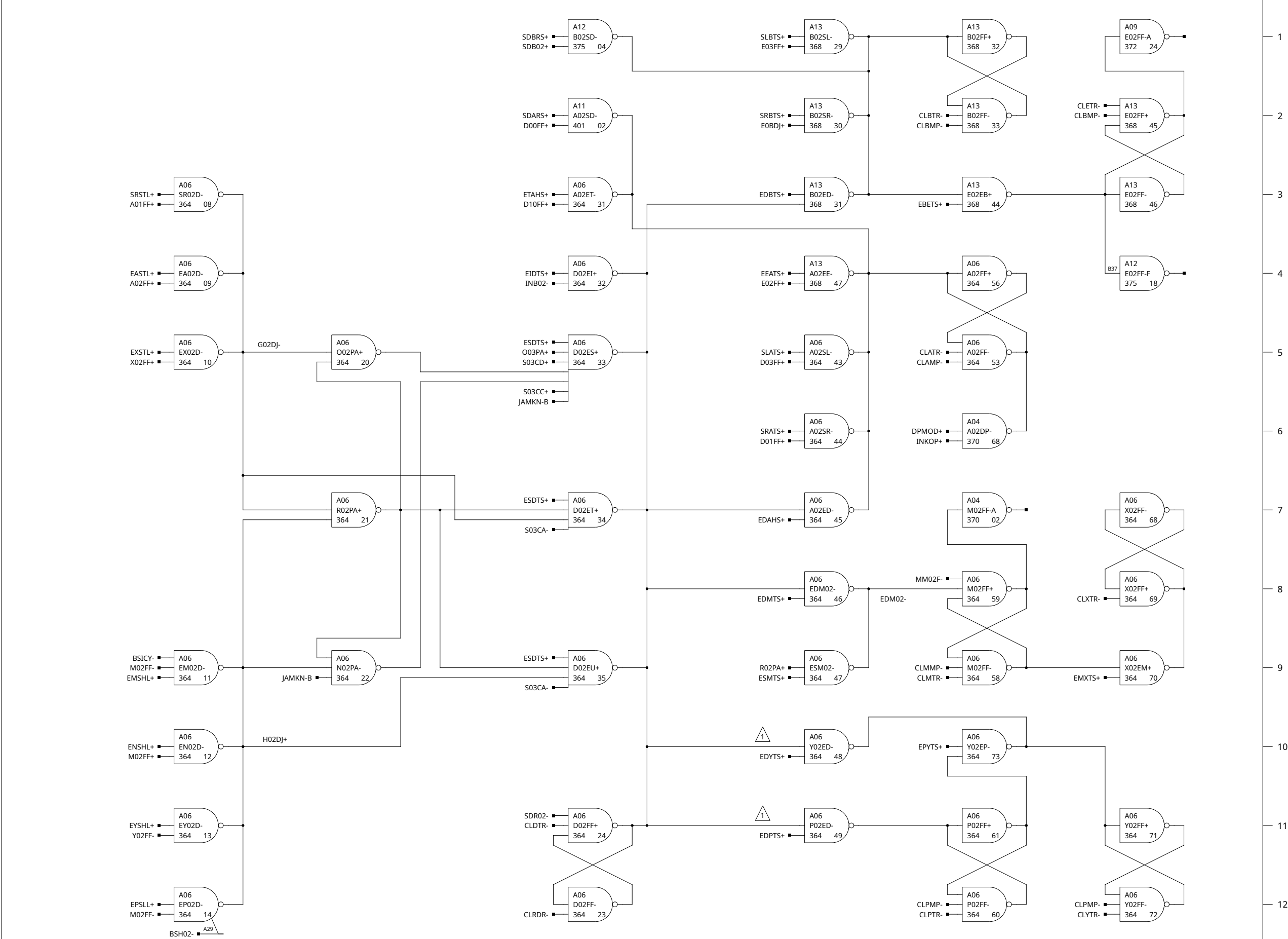

**NOTES:**  
 1. DELETE D02FF+ AND ADD BSD02+ WITH EXT. ADD OPTION  
 2.  
 3.  
 4.

REV.	DATE	DESCRIPTION
A	1/19/70	ECO 7748 EXT CHANGES SEE ECO 7748
B		
C		
D		
E		
F		
G		
H		
J		
K		
L		
M		
N		
P		

**HONEYWELL**  
 INC  
 COMPUTER CONTROL DIVISION  
 Old Connecticut Path, Framingham, Mass

DR. D. HAMEL	DATE
ENG. K. IZBICKI	11-26-68
APP.	7-8-69

PROJECT NO. 55202

TITLE	H-316
COLUMN No.	2
SIZE	C
DWG NO.	70024486
REV.	B

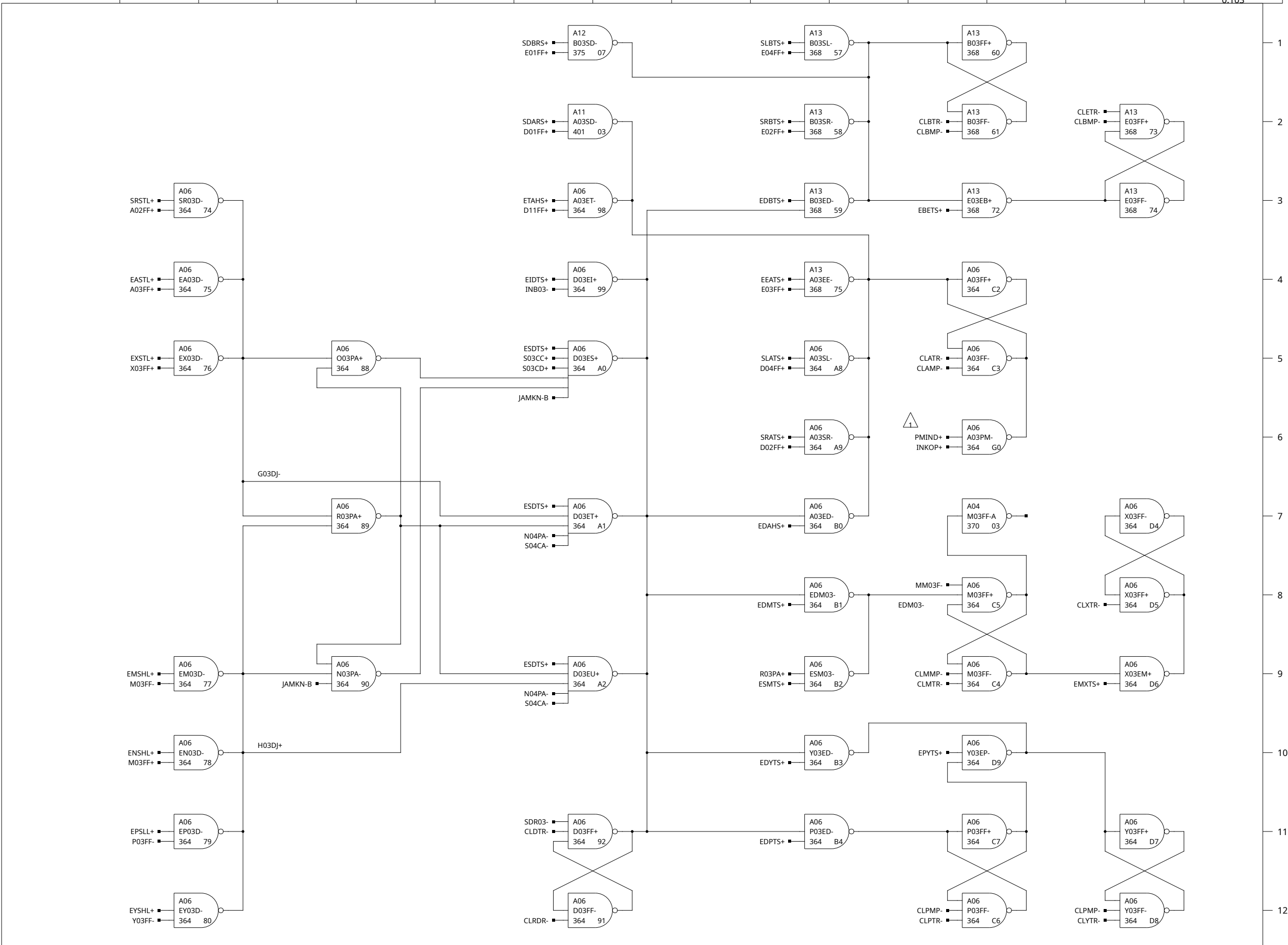

NOTES:  
 △ THIS PT MUST BE GND WITH NO EXT ADD OPTION  
 △  
 △  
 △  
 △

REV.	A
REVISIONS	
CHK.	
S. R.	54-3585
EXT CHANGES SEE ECO TA.	
N 8220 105000 77880 1090081	
1/19/70	

**HONEYWELL**  
 INC  
 COMPUTER CONTROL DIVISION  
 Old Connecticut Path, Framingham, Mass

DR. D. HAMEL	DATE
ENG. K. IZBICKI	11-26-68
APP.	7-8-69

PROJECT NO. 55202

TITLE	H-316
	COLUMN No. 3
SIZE	DWG NO.
C	70024487
REV.	B

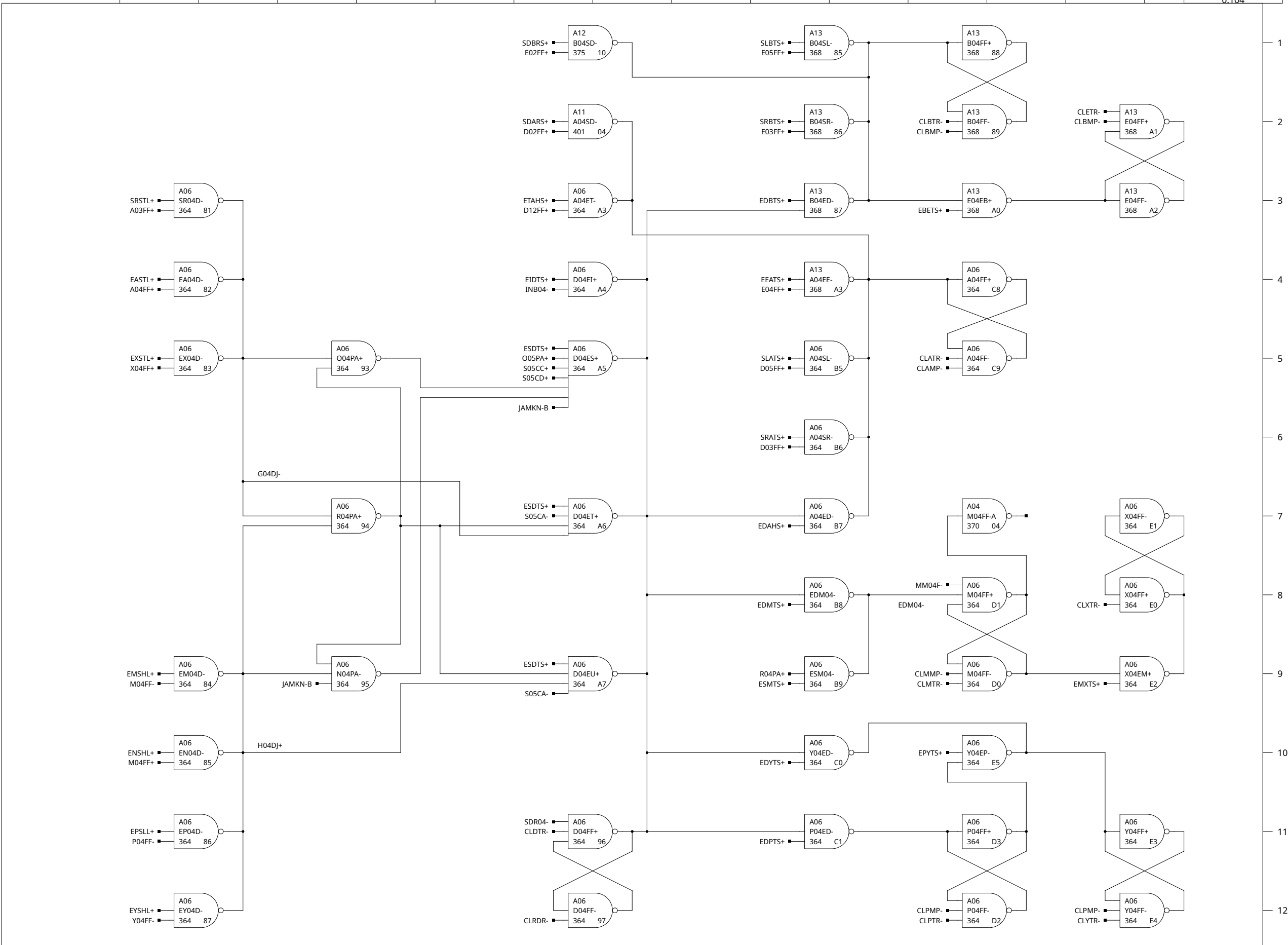

NOTES:  
 △  
 △  
 △  
 △

REV.	REVISIONS
A	
B	

1/19/70  
 S. R. 54-3585  
 ECO 7748  
 EXT CHANGES SEE ECO T.A.

**HONEYWELL**  
 INC  
 COMPUTER CONTROL DIVISION  
 Old Connecticut Path, Framingham, Mass

DR. D. HAMEL  
 ENG. K. IZBICKI  
 APP.

DATE  
 11-26-68  
 7-2-69

PROJECT NO. 55202

TITLE  
 H-316  
 COLUMN No. 4

SIZE DWG NO. REV.  
 C 70024488 B

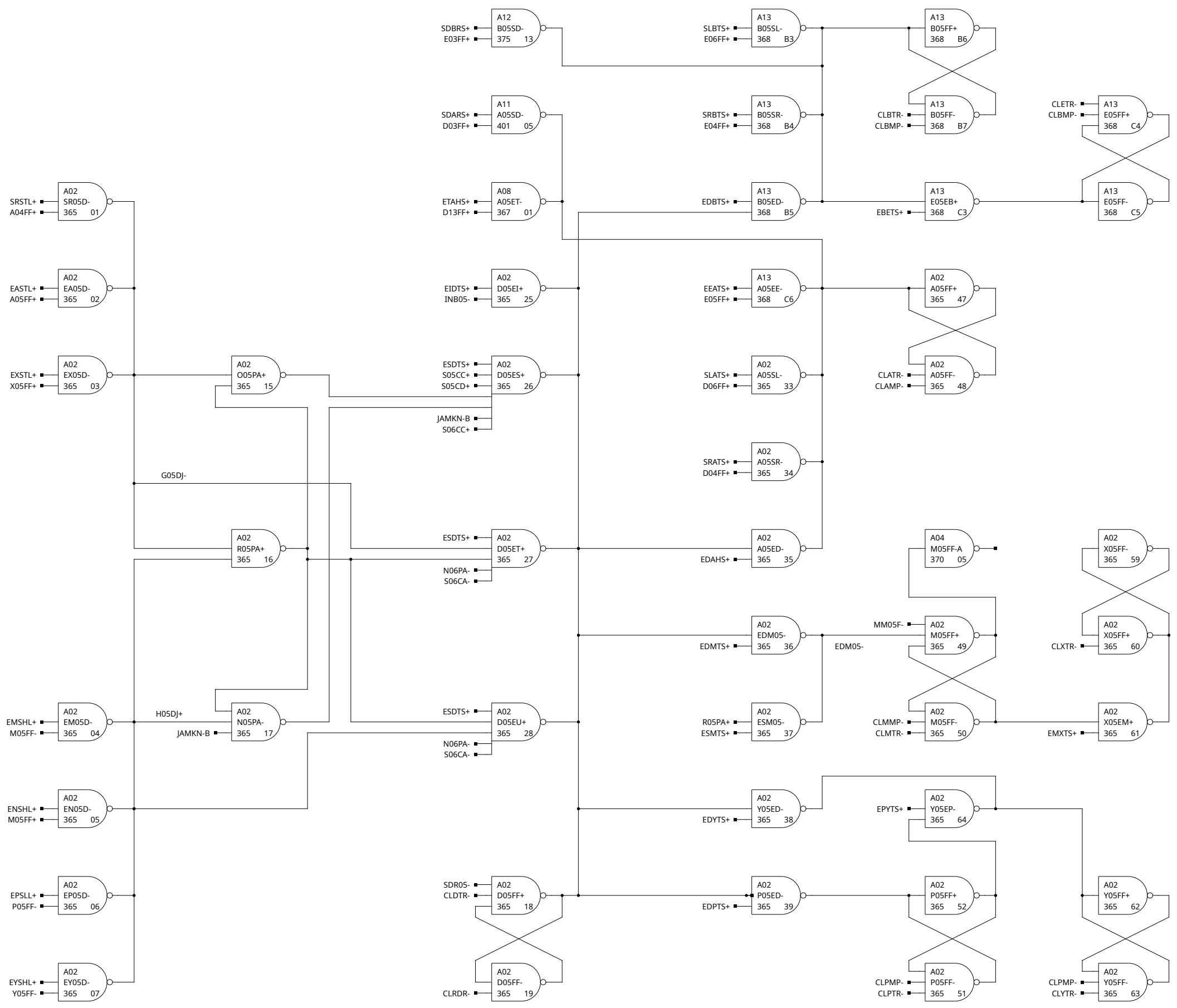

NOTES:  
 △  
 △  
 △  
 △

REV.	REVISIONS
A	
B	

S. R. 54-3585  
 ECO 7748  
 EXT CHANGES SEE ECO T.A.

**HONEYWELL**  
 INC  
 COMPUTER CONTROL DIVISION  
 Old Connecticut Path, Framingham, Mass

DR. D. HAMEL	DATE
ENG. K. IZBICKI	11-26-68
APP.	7-2-69

PROJECT NO. 55202

TITLE	H-316
	COLUMN No. 5
SIZE	DWG NO.
C	70024489
REV.	B

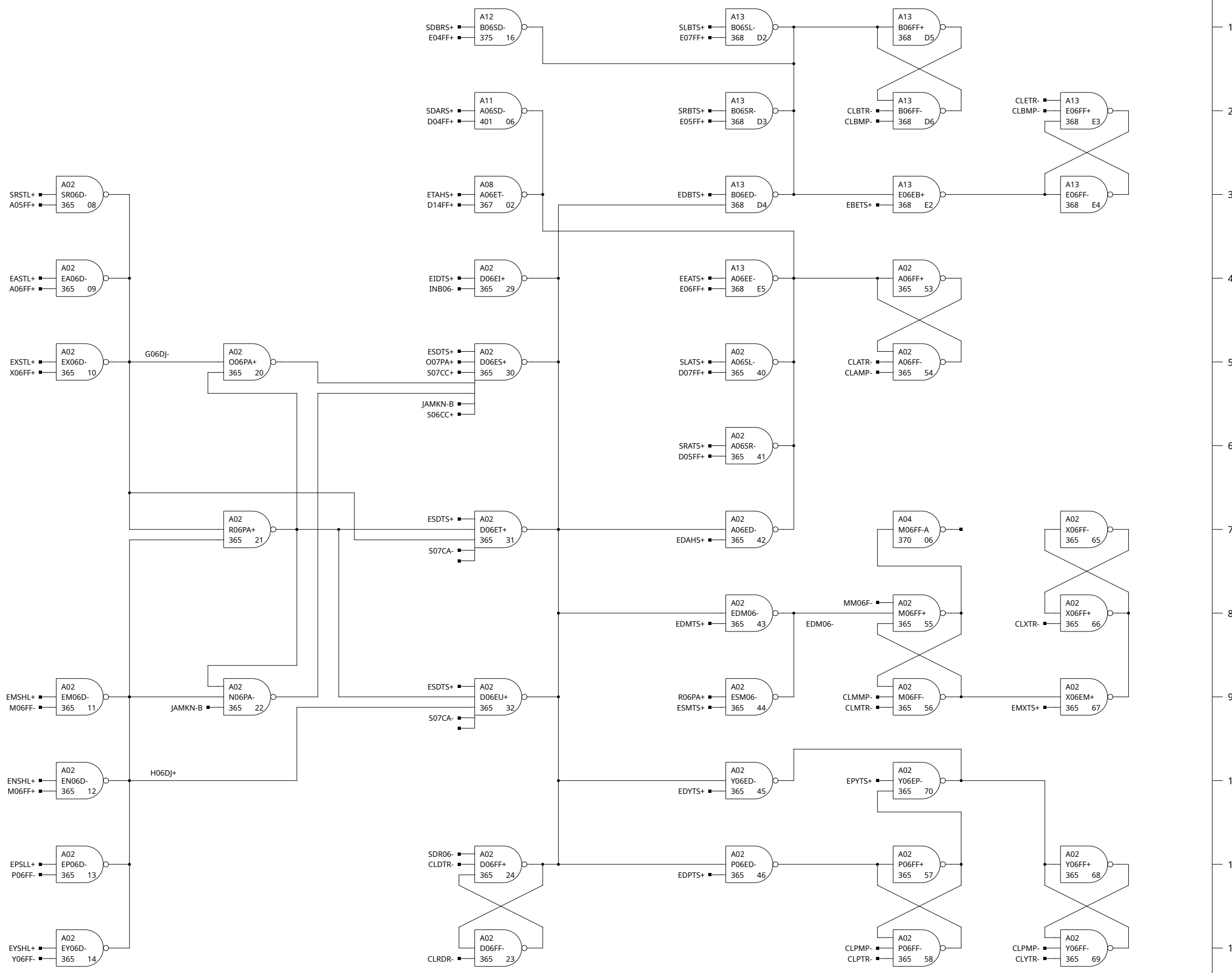

REV.	DATE	BY	CHK.
A	1/19/70	B	
S. R. 54-3585			
ECO 7748			
EXT CHANGES SEE ECO 7748			

**HONEYWELL**  
 INC  
 COMPUTER CONTROL DIVISION  
 Old Connecticut Path, Framingham, Mass

DR. D. HAMEL	DATE
ENG. K. IZBICKI	11-26-68
APP.	7-2-69

PROJECT NO. 55202

TITLE	H-316
COLUMN No.	6
SIZE	DWG NO.
C	70024490
REV.	B

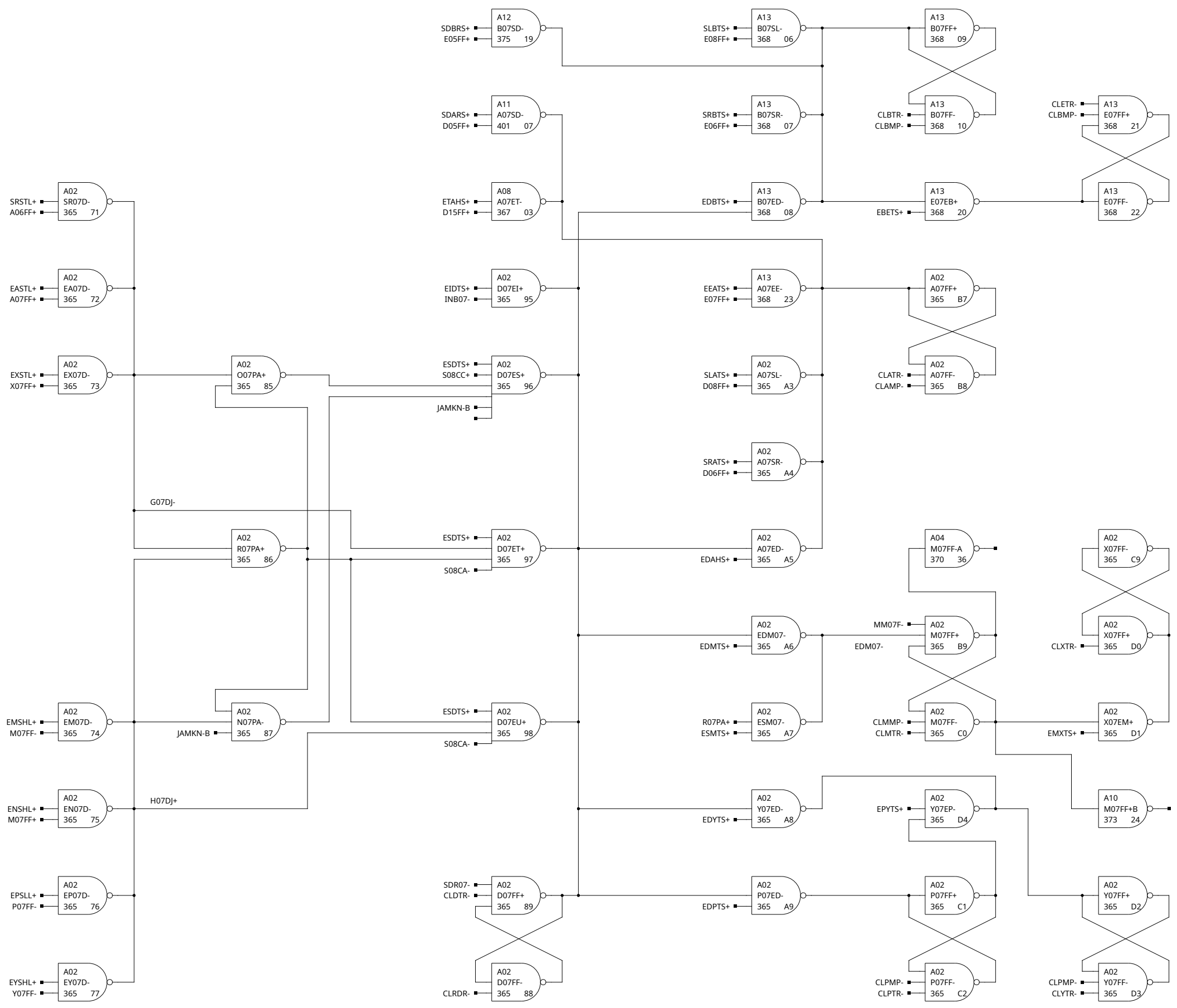

NOTES:  
 △  
 △  
 △  
 △

REV.	REVISIONS
A	
B	ECO 7748 EXT CHANGES SEE ECO 7748
1/19/70	

S. R. 54-3585

**HONEYWELL**  
 INC  
 COMPUTER CONTROL DIVISION  
 Old Connecticut Path, Framingham, Mass

DR. D. HAMEL  
 ENG. K. IZBICKI  
 APP.

DATE  
 11-26-68  
 7-2-69

PROJECT NO. 55202

TITLE  
 H-316  
 COLUMN No. 7

SIZE DWG NO.  
 C 70024491

REV.  
 B

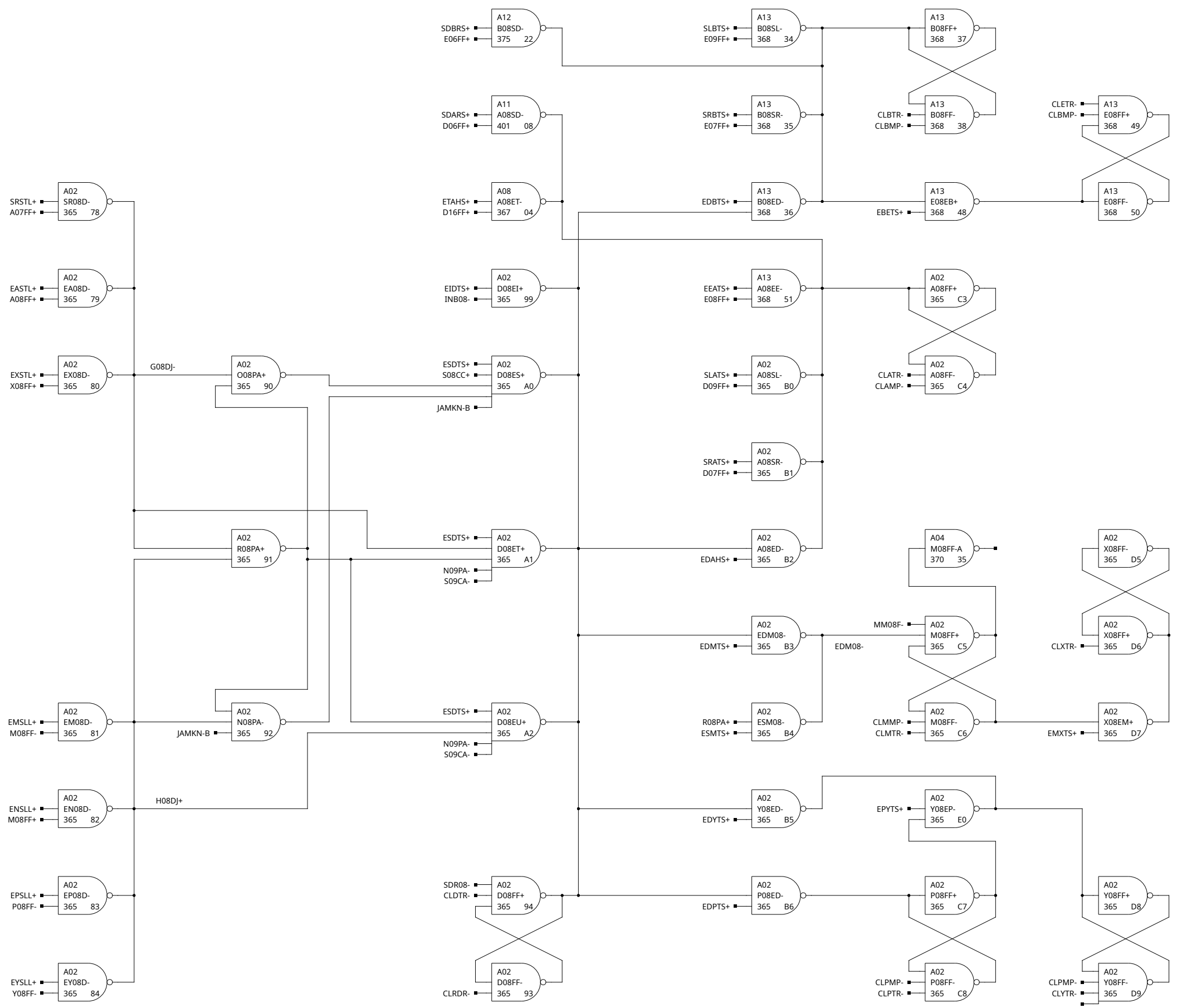

1  
2  
3  
4  
5  
6  
7  
8  
9  
10  
11  
12

NOTES:  
△  
△  
△  
△

REV.	DATE	DESCRIPTION
A	1/19/70	EXT CHANGES SEE ECO T.A.
B		
C		
D		
E		
F		
G		
H		
J		
K		
L		
M		
N		
P		

**HONEYWELL**  
INC  
COMPUTER CONTROL DIVISION  
Old Connecticut Path, Framingham, Mass

DR. D. HAMEL  
ENG. K. IZBICKI  
APP.

DATE  
11-26-68  
7-2-69

PROJECT NO. 55202

TITLE  
H-316  
COLUMN No. 8

SIZE DWG NO. REV.  
C 70024492 B



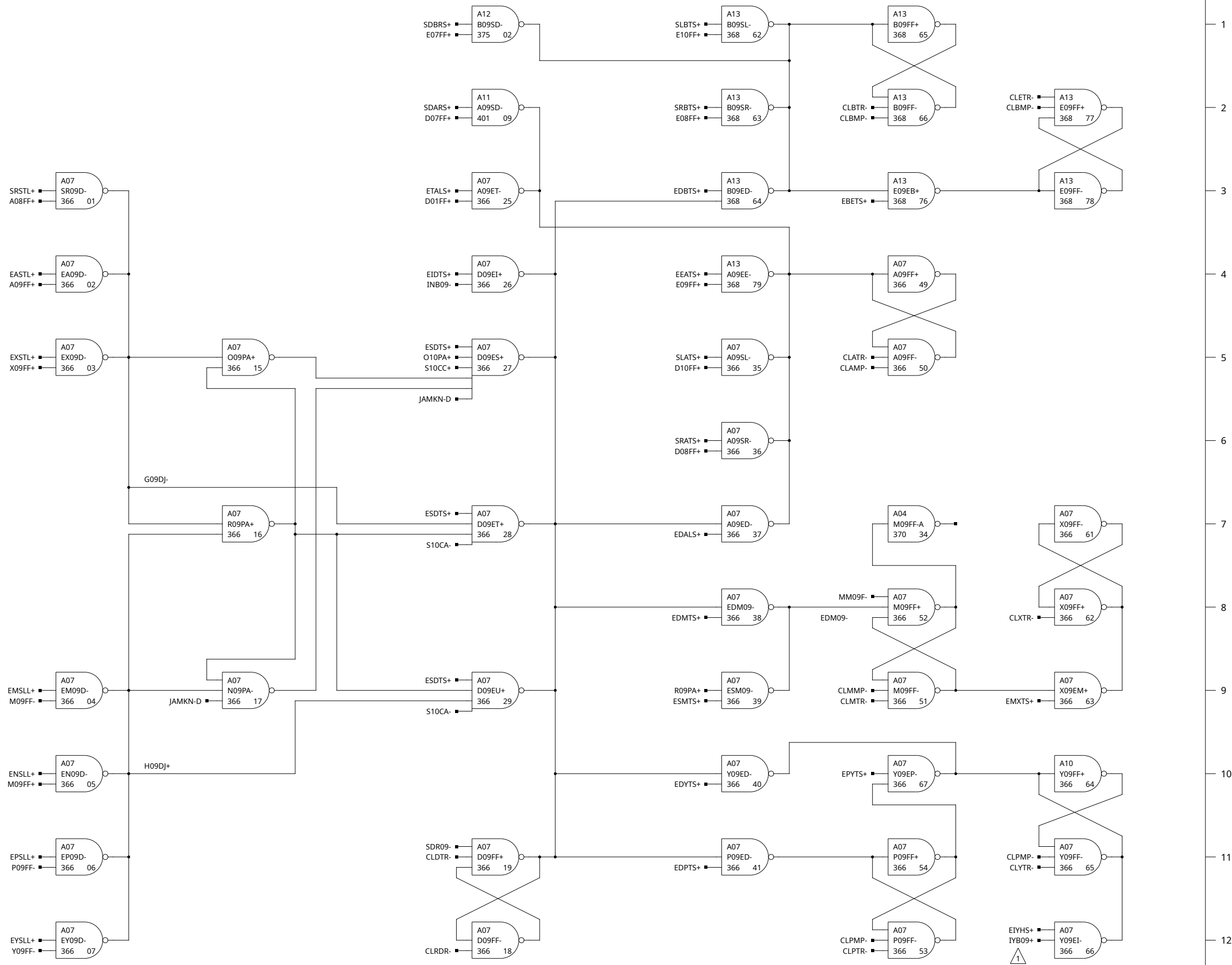

NOTES:  
 △ THIS PT. IS GND WITH NO DMC OPTION  
 △  
 △  
 △

REV.	REVISIONS
A	
B	

1/19/70  
 S. R. 54-3585  
 ECO 7748  
 EXT CHANGES SEE ECO T.A.

**HONEYWELL**  
 INC  
 COMPUTER CONTROL DIVISION  
 Old Connecticut Path, Framingham, Mass

DR. D. HAMEL  
 ENG. K. IZBICKI  
 APP.

DATE  
 11-26-68  
 7-2-69

PROJECT NO. 55202

TITLE  
 H-316  
 COLUMN No. 9

SIZE DWG NO. REV.  
 C 70024493 B

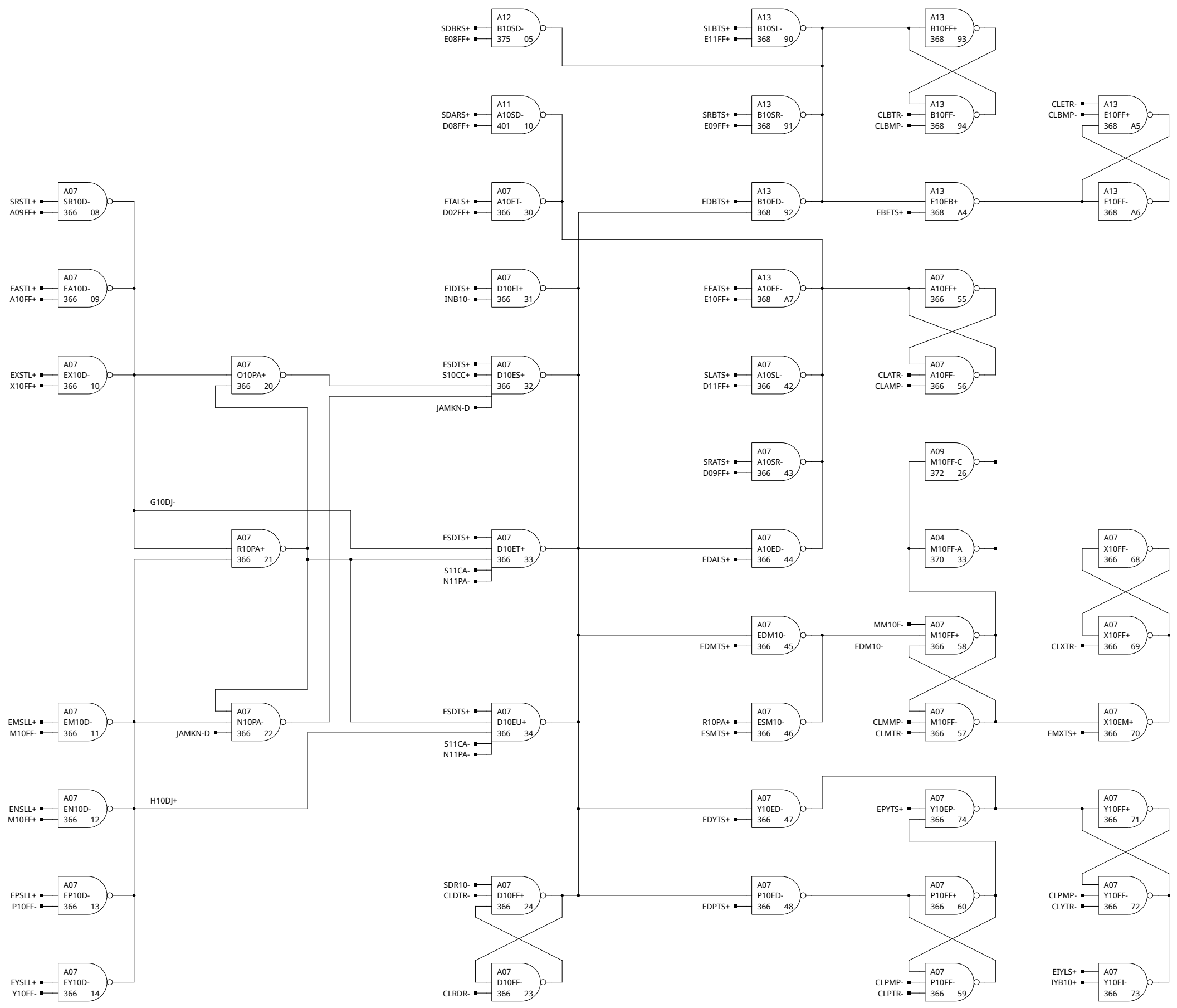

1  
2  
3  
4  
5  
6  
7  
8  
9  
10  
11  
12

NOTES:  
△  
△  
△  
△

REV.	REVISIONS
A	
B	

1/19/70  
S. R. 54-3585  
ECO 7748  
EXT CHANGES SEE ECO T.A.

**HONEYWELL**  
INC  
COMPUTER CONTROL DIVISION  
Old Connecticut Path, Framingham, Mass

DR. D. HAMEL  
ENG. K. IZBICKI  
APP.

DATE  
11-26-68  
7-2-69

PROJECT NO. 55202

TITLE  
H-316  
COLUMN No. 10

SIZE DWG NO. REV.  
C 70024494 B

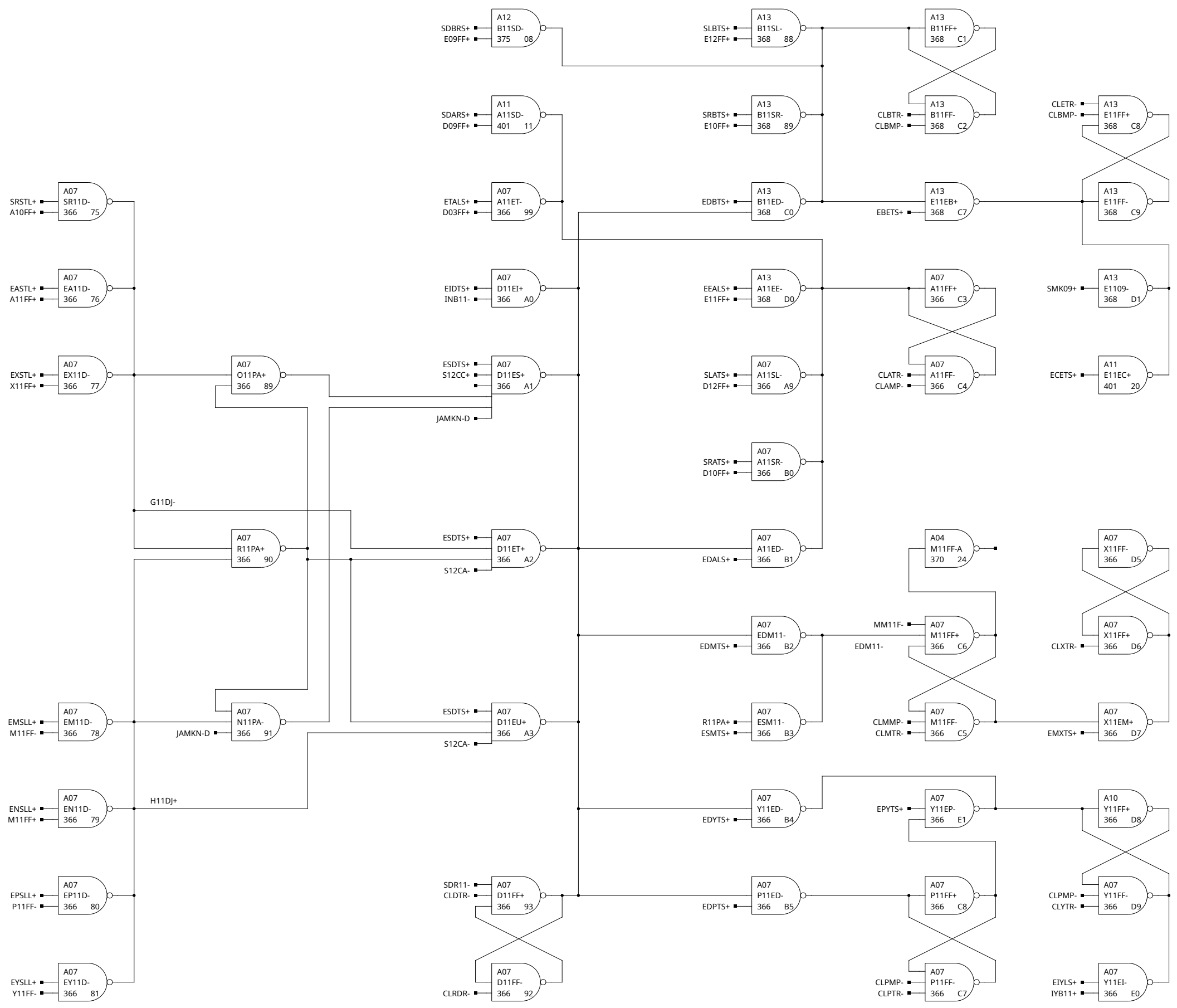

NOTES:  
 △  
 △  
 △  
 △

REV.	REVISIONS
A	
B	

1/19/70  
 S. R. 54-3585  
 ECO 7748  
 EXT CHANGES  
 SEE ECO 7748

**HONEYWELL**  
 INC  
 COMPUTER CONTROL DIVISION  
 Old Connecticut Path, Framingham, Mass

DR. D. HAMEL	DATE
ENG. K. IZBICKI	11-25-68
APP.	7-2-69

PROJECT NO. 55202

TITLE	H-316
	COLUMN No. 11
SIZE	DWG NO.
C	70024495
REV.	B

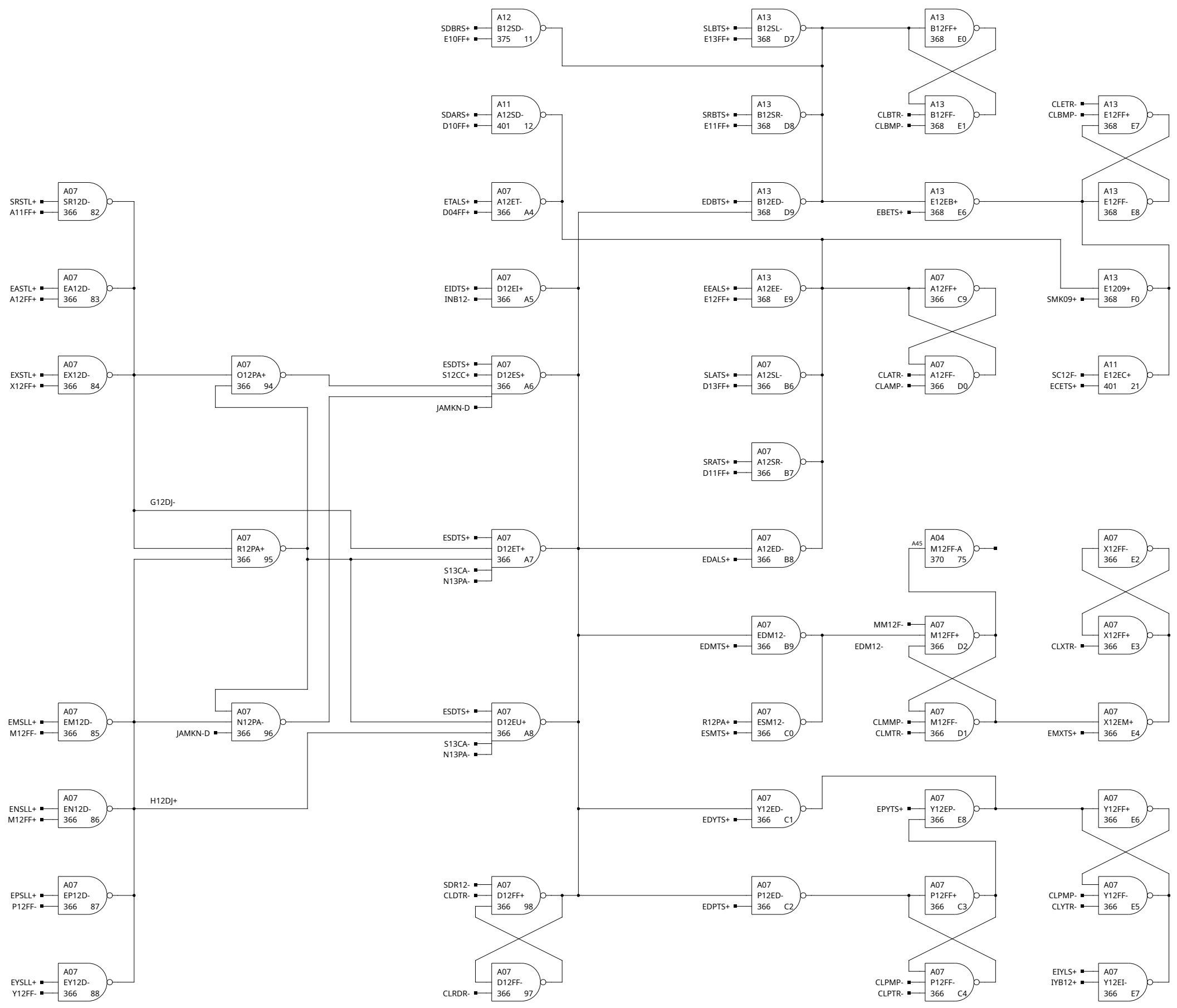

NOTES:  
 △  
 △  
 △  
 △

REV.	DATE	DESCRIPTION
A	1/19/70	EXT CHANGES SEE ECO T.A.
B	ECO 7748	EXT CHANGES SEE ECO T.A.

S. R. 54-3585

**HONEYWELL**  
 INC  
 COMPUTER CONTROL DIVISION  
 Old Connecticut Path, Framingham, Mass

DR. D. HAMEL	DATE
ENG. K. IZBICKI	11-26-68
APP.	7-2-69

PROJECT NO. 55202

TITLE	H-316
COLUMN No.	12
SIZE	DWG NO. 70024496
REV.	B

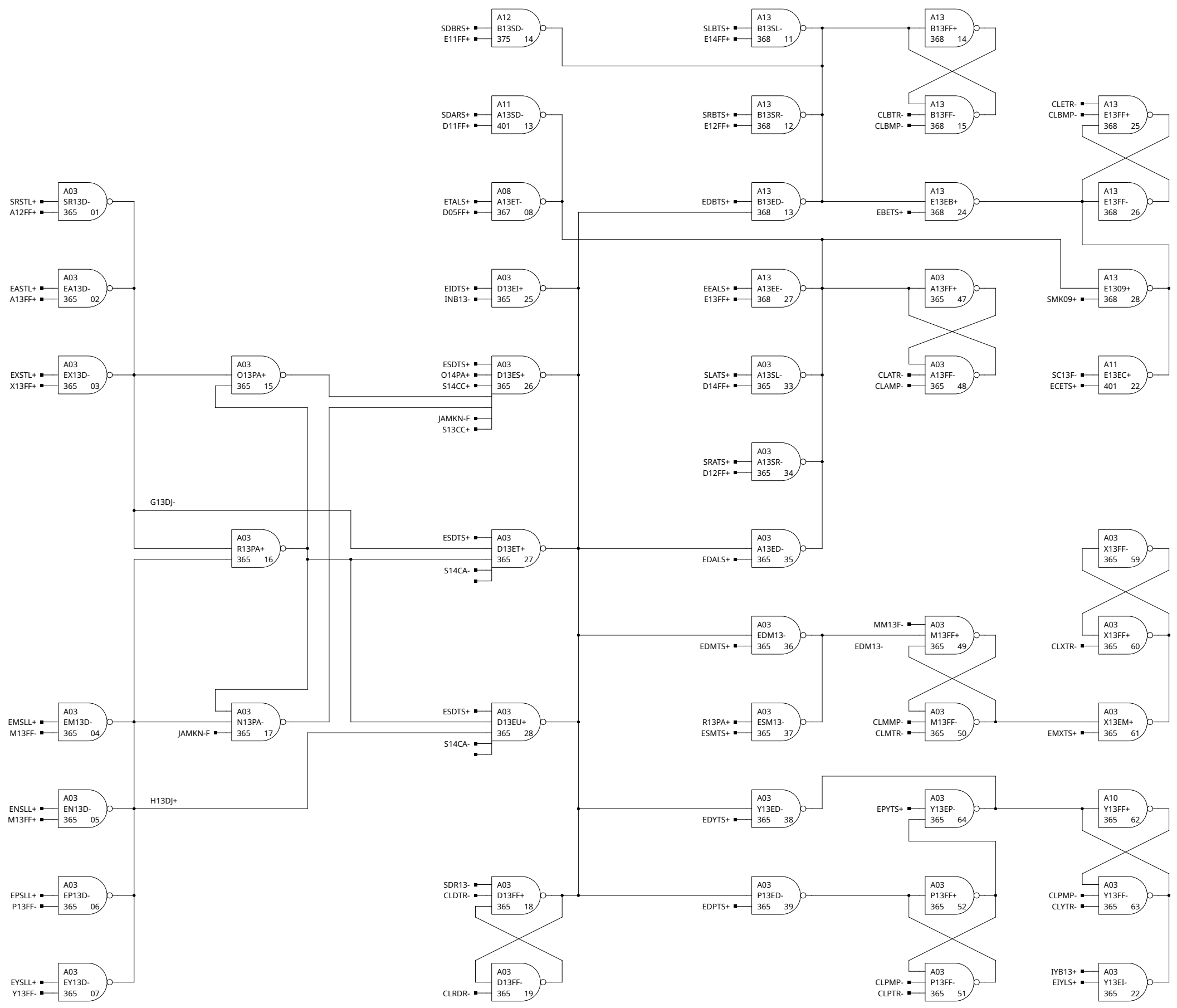

NOTES:  
 △  
 △  
 △  
 △

REV.	REVISIONS
A	
B	1/19/70
	ECO 7748
	EXT CHANGES SEE ECO 7748

S. R. 54-3585

**HONEYWELL**  
 INC  
 COMPUTER CONTROL DIVISION  
 Old Connecticut Path, Framingham, Mass

DR. D. HAMEL	DATE
ENG. K. IZBICKI	11-26-68
APP.	7-2-69

PROJECT NO. 55202

TITLE	H-316
	COLUMN No. 13
SIZE	DWG NO.
C	70024497
REV.	B

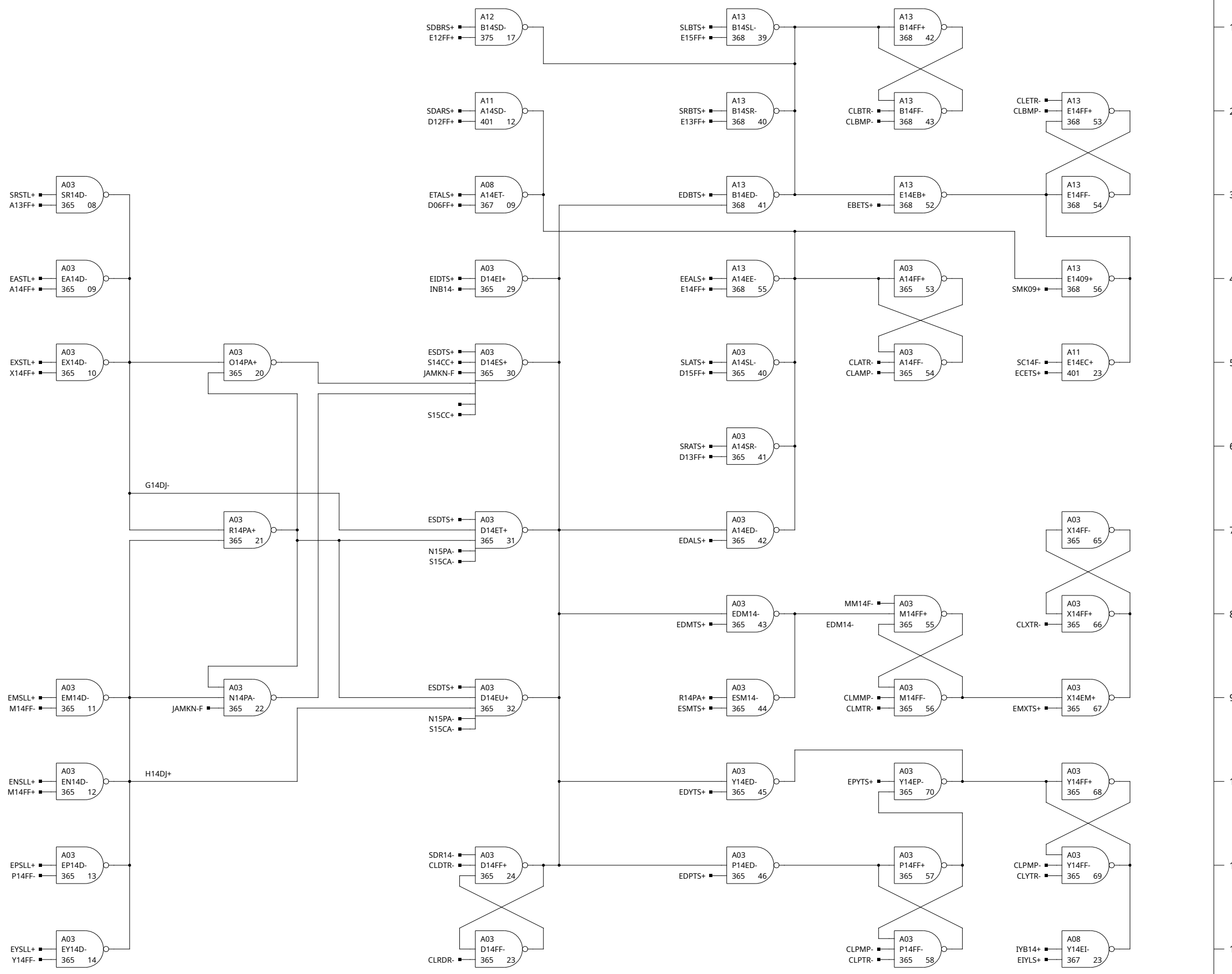

NOTES:  
 △  
 △  
 △  
 △

REV.	REVISIONS
A	
B	1/19/70
	ECO 7748
	EXT CHANGES
	SEE ECO 7748

S. R. 54-3585

**HONEYWELL**  
 INC  
 COMPUTER CONTROL DIVISION  
 Old Connecticut Path, Framingham, Mass

DR. D. HAMEL DATE  
 ENG. K. IZBICKI 11-26-68  
 APP. 7-2-69

PROJECT NO. 55202

TITLE  
 H-316  
 COLUMN No. 12

SIZE DWG NO. REV.  
 C 70024498 B

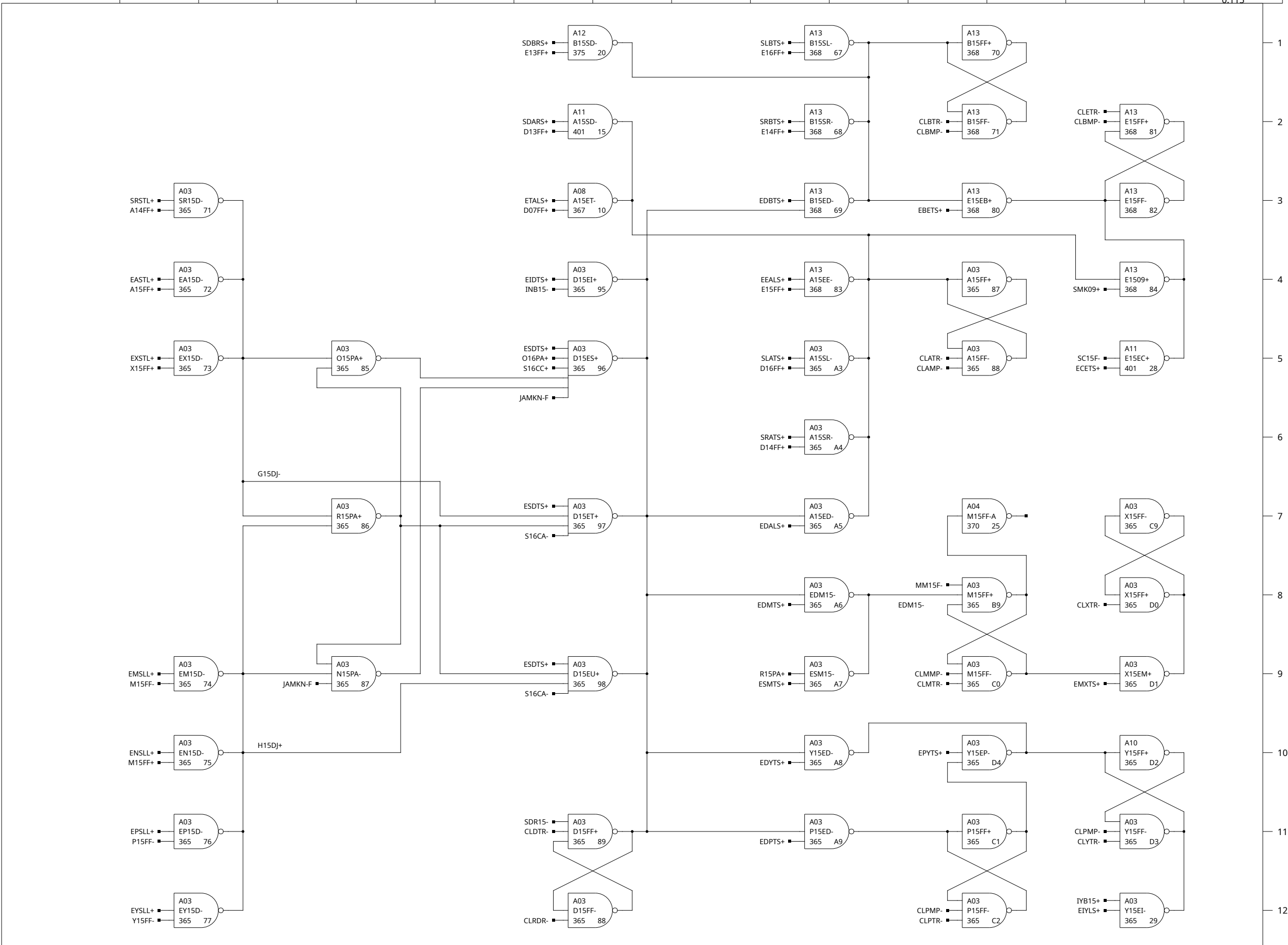

NOTES:  
 △  
 △  
 △  
 △

REV.	DATE	DESCRIPTION
A	1/19/70	ECO 7748 EXT CHANGES SEE ECO 7748
B		
C		
D		
E		
F		
G		
H		
J		
K		
L		
M		
N		
P		

**HONEYWELL**  
 INC  
 COMPUTER CONTROL DIVISION  
 Old Connecticut Path, Framingham, Mass

DR. D. HAMEL	DATE
ENG. K. IZBICKI	11-26-68
APP.	7-2-69

PROJECT NO. 55202

TITLE	H-316
	COLUMN No. 15
SIZE	DWG NO.
C	70024499
REV.	B

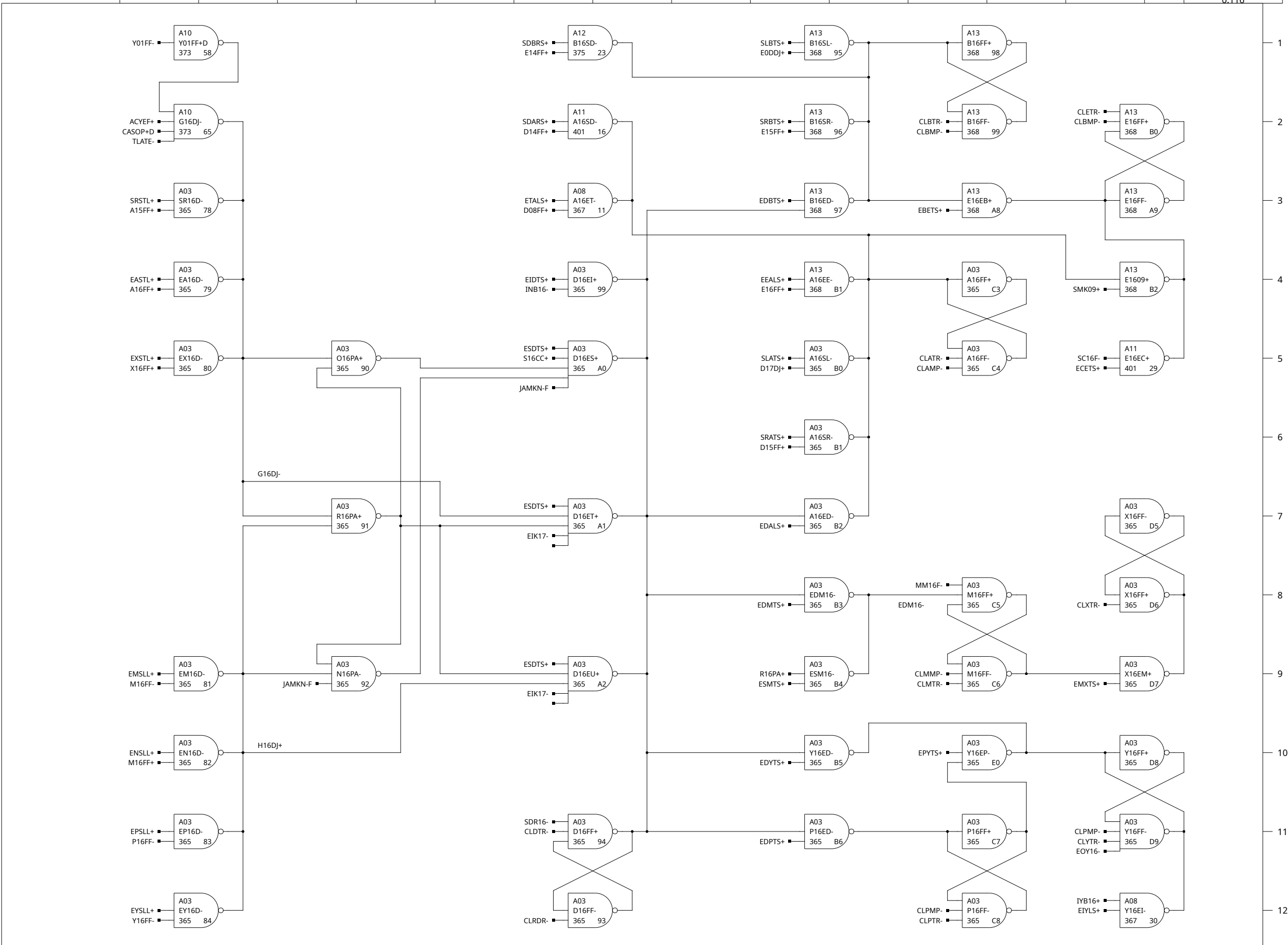

NOTES:  
 △  
 △  
 △  
 △

REV.	REVISIONS	DATE
A		
B		

S. R. 54-3585  
 ECO 7748  
 EXT CHANGES SEE ECO T.A.

**HONEYWELL**  
 INC  
 COMPUTER CONTROL DIVISION  
 Old Connecticut Path, Framingham, Mass

DR. D. HAMEL  
 ENG. K. IZBICKI  
 APP. \_\_\_\_\_

DATE  
 11-26-68  
 7-2-69

PROJECT NO. 55202

TITLE  
 H-316  
 COLUMN No. 16

SIZE DWG NO. REV.  
 C 70024500 B



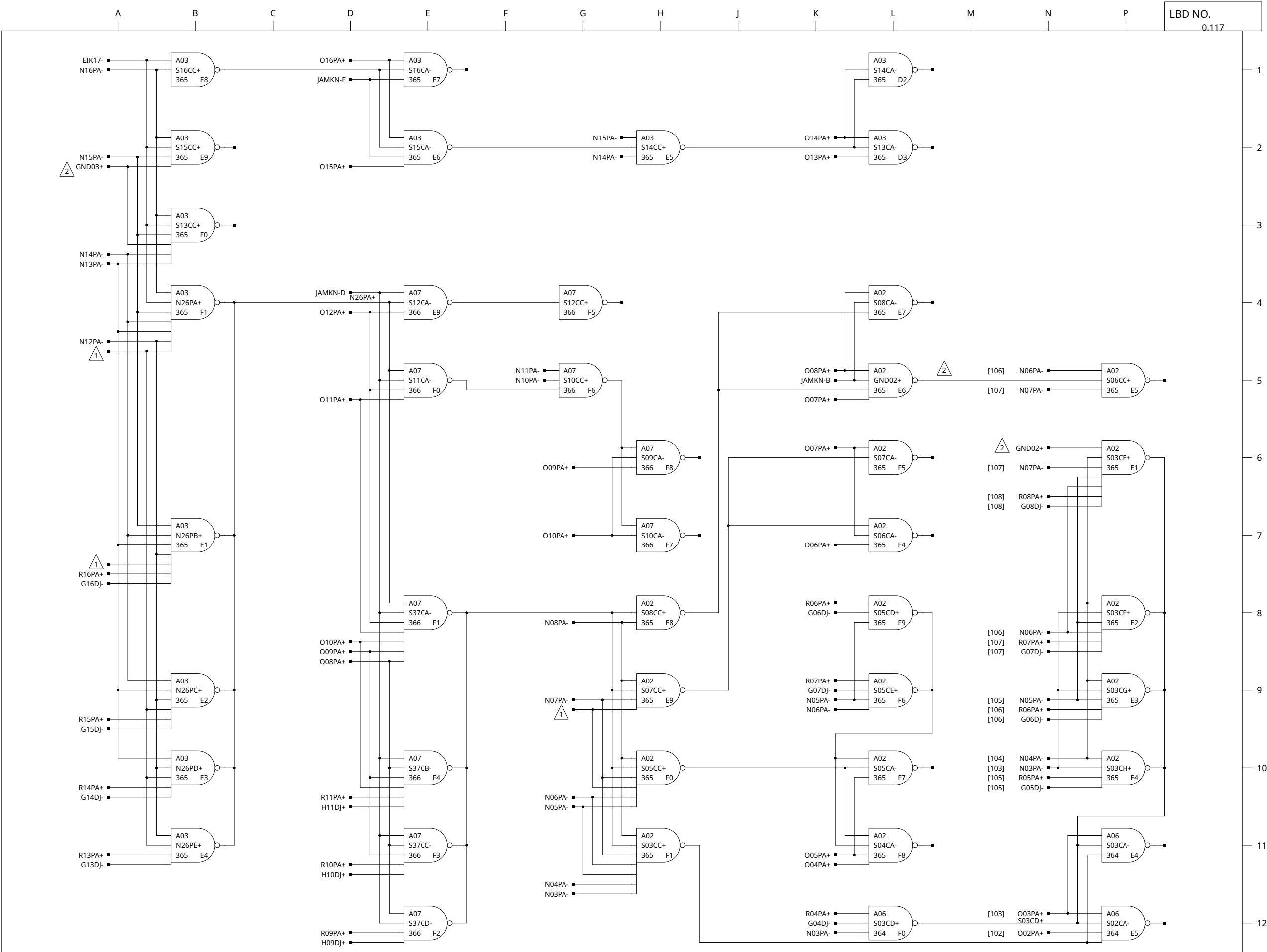

**NOTES:**

- △ THESE PTS ARE FLOATING. THIS IS DUE TO THE DOUBLE USAGE OF CC365
- △ THESE PTS ARE TIED TO THEIR PAC GROUNDS. THIS IS DUE TO THE DOUBLE USAGE OF CC365

REV.	REVISIONS	DATE
A		
B	ECO 7748	1/19/70
	EXT CHANGES SEE ECO 7748	

S. R. 54-3585

**HONEYWELL**  
INC  
COMPUTER CONTROL DIVISION  
Old Connecticut Path, Framingham, Mass

DR. D. HAMEL	DATE
ENG. K. IZBICKI	11-27-1968
APP.	4-1-69

PROJECT NO. 55202

TITLE	H-316
	CARRY NETWORK
SIZE	DWG NO.
C	70024501
REV.	B

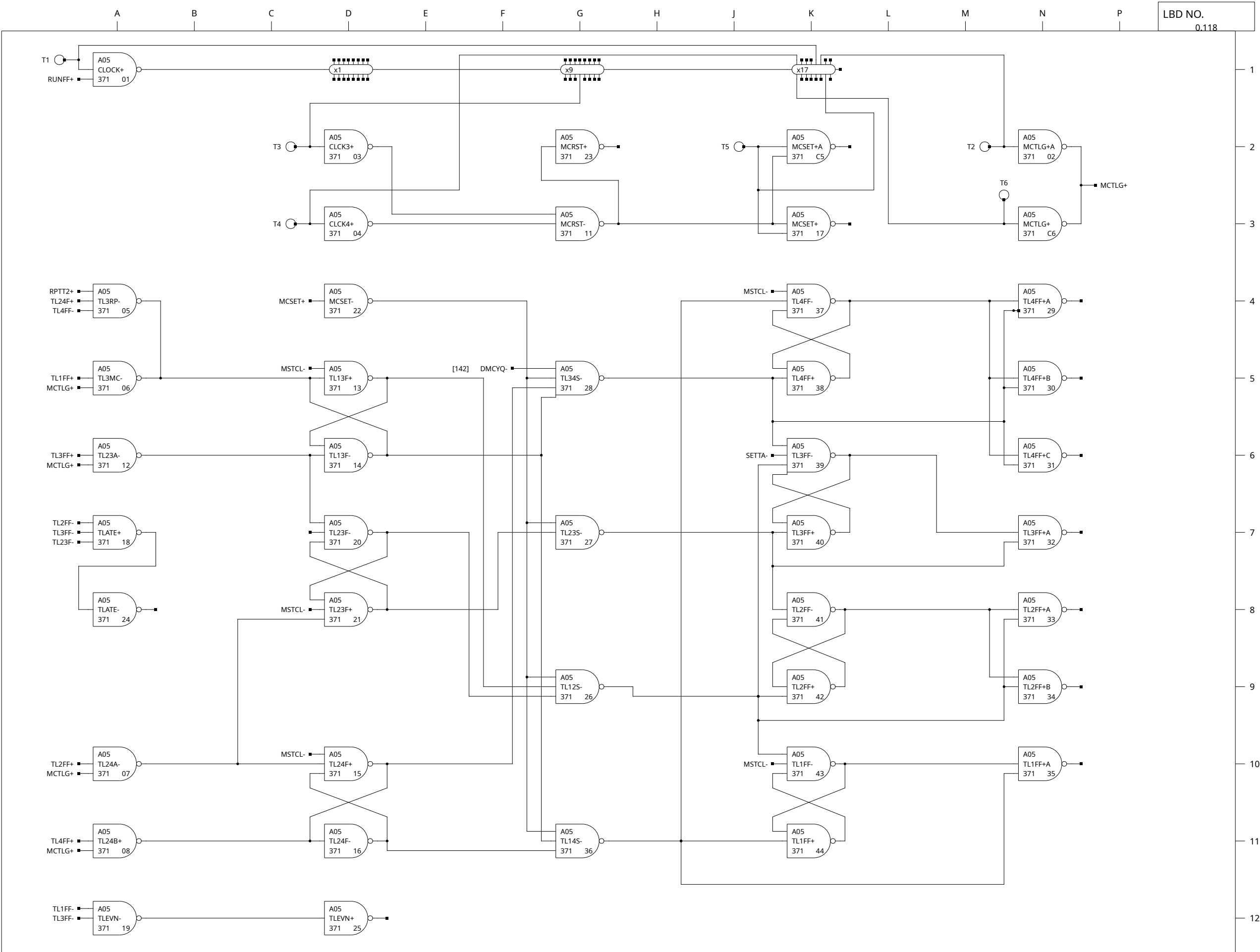

LBD NO. 0.118

- NOTES:  
 △  
 △  
 △  
 △

REV.	REVISIONS	DATE
A		
B	ECO 7748	1/19/70
	EXT CHANGES SEE ECO 7748	
	S. R. 54-3585	

**HONEYWELL**  
 INC  
 COMPUTER CONTROL DIVISION  
 Old Connecticut Path, Framingham, Mass

DR. D. HAMEL	DATE
ENG. K. IZBICKI	1-9-1969
APP.	7-2-69

PROJECT NO. 55202

TITLE	H-316	REV.	B
	TLG AND CLOCK		
SIZE	DWG NO.		
C	70024502		

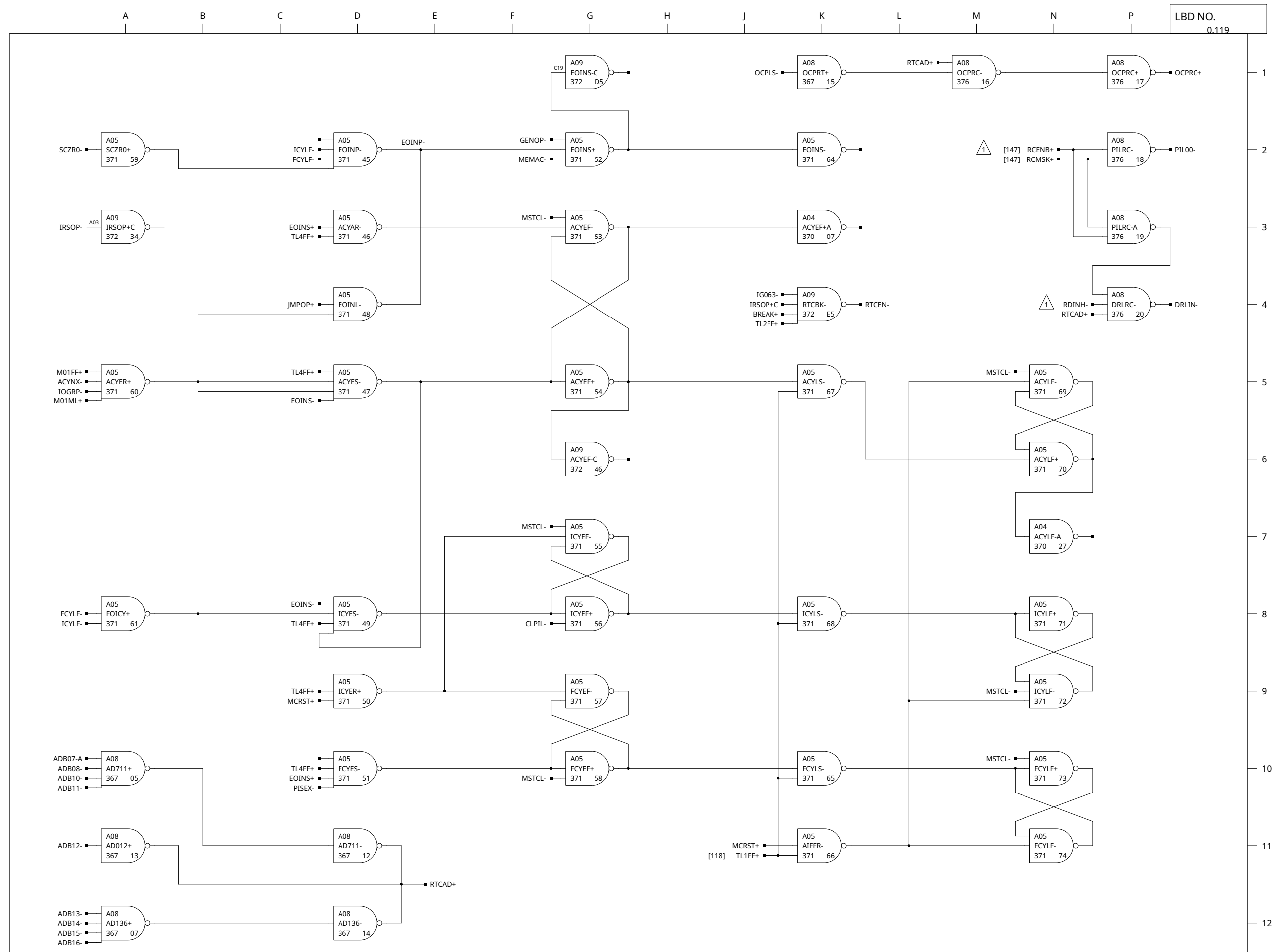

**NOTES-**

- △ REMOVE GROUND WHEN USING REAL TIME CLOCK
- △
- △
- △

REV.	REVISIONS	DATE
A		
B		

S. R. 54-3585  
 ECO 7/48  
 EXT CHANGES SEE ECO T.A.

		TITLE	
		H-316	
COMPUTER CONTROL DIVISION		PHASE REGISTER	
Old Connecticut Path, Framingham, Mass			
DR. D. HAMEL	DATE	SIZE	DWG NO.
ENG. K. IZBICKI	12-12-1968		
APP.	4-1-69	C	70024503
PROJECT NO.	55202		

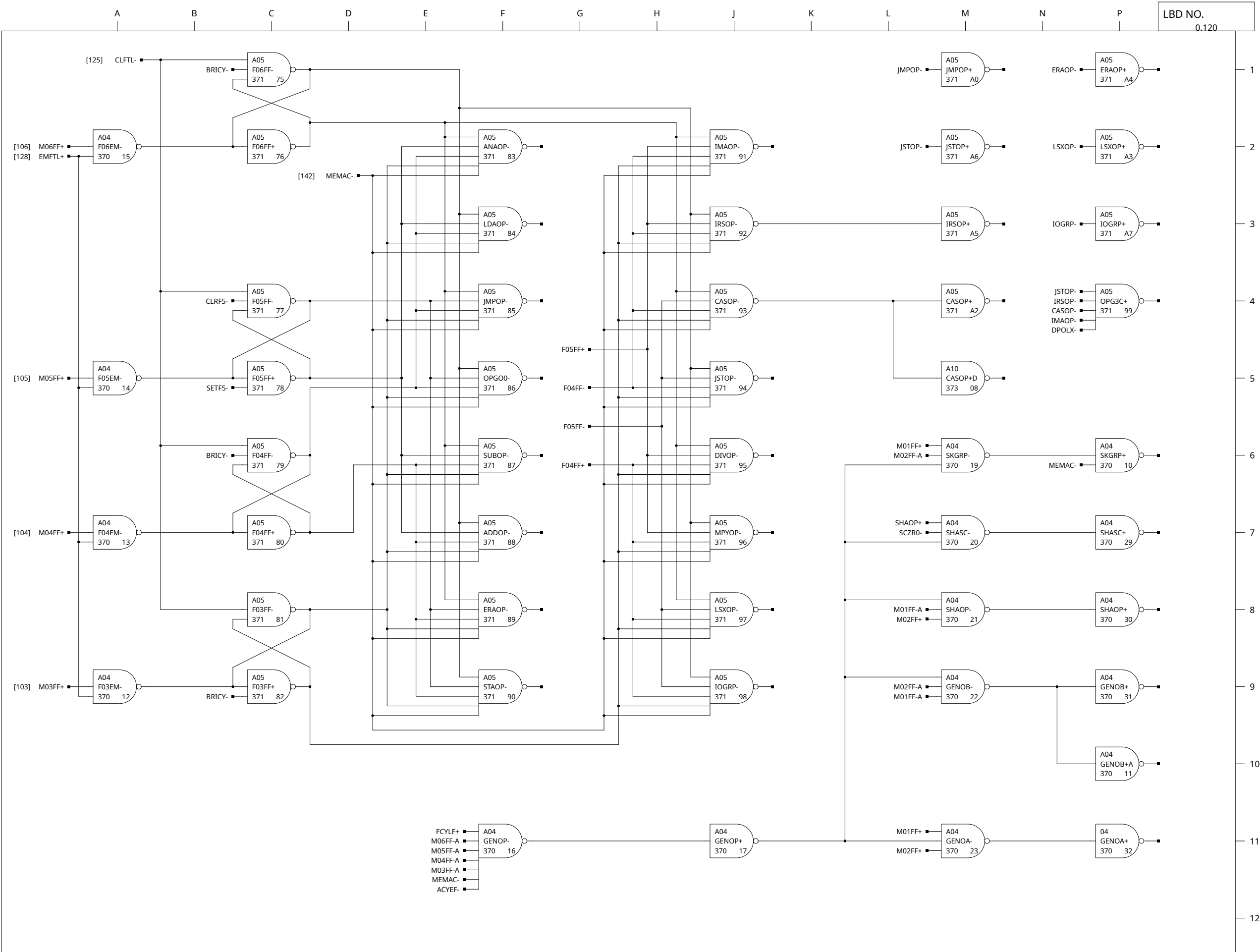

NOTES:  
 △  
 △  
 △  
 △

CHK.	REV.	REVISIONS
	A	
	B	

S. R. 54-3585  
 ECO 7748  
 EXT CHANGES  
 SEECOT.A.  
 1/19/70

**HONEYWELL**  
 INC  
 COMPUTER CONTROL DIVISION  
 Old Connecticut Path, Framingham, Mass

DR. D. HAMEL	DATE
ENG. K. IZBICKI	13-12-68
APP.	17-2-69

PROJECT NO. 55202

TITLE	H-316
	F REG & OP DECODE
SIZE	DWG NO.
C	70024504
REV.	B

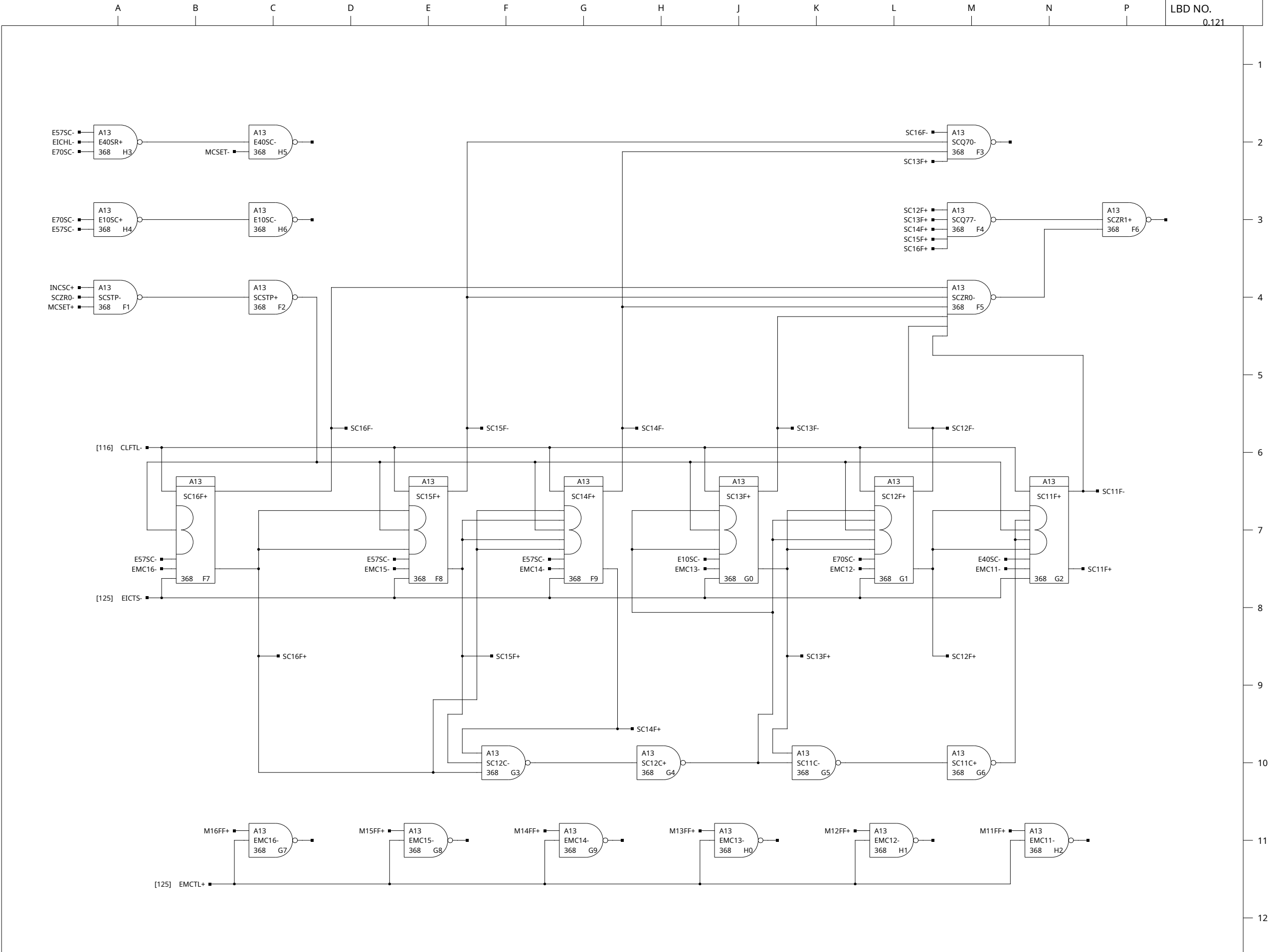

- NOTES:
- △
  - △
  - △
  - △

CHK.	REVISIONS	REV.	DATE
		A	
		B	1/19/70

**HONEYWELL**  
INC  
COMPUTER CONTROL DIVISION  
Old Connecticut Path, Framingham, Mass

DR. D. HAMEL	DATE
ENG. K. IZBICKI	12-20-1968
APP.	17-2-69

PROJECT NO. 55202

TITLE		H-316	
		SHIFT COUNTER	
SIZE	DWG NO.	REV.	
C	70024505	B	

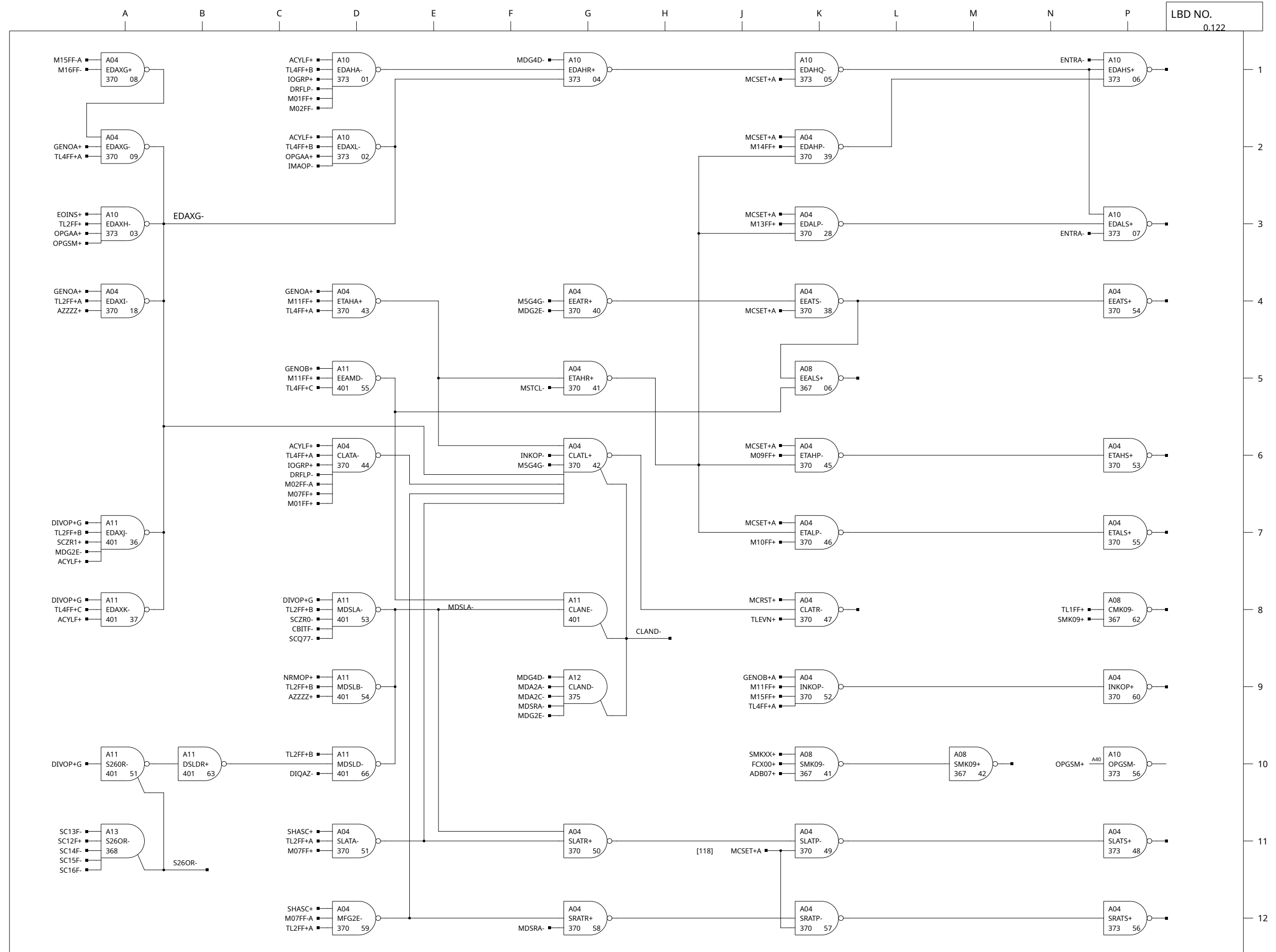

- NOTES:
- △
  - △
  - △
  - △

REV.	REVISIONS
A	
B	1/19/70
	ECO 7748
	EXT CHANGES SEE ECO T.A.

S. R. 54-3585

**HONEYWELL**  
 INC  
 COMPUTER CONTROL DIVISION  
 Old Connecticut Path, Framingham, Mass

DR. D. HAMEL	DATE
ENG. K. IZBICKI	12-23-68
APP.	7-2-69

PROJECT NO. 55202

TITLE		H-316	
CONTROL LOGIC A			
SIZE	DWG NO.	REV.	
C	70024506	B	

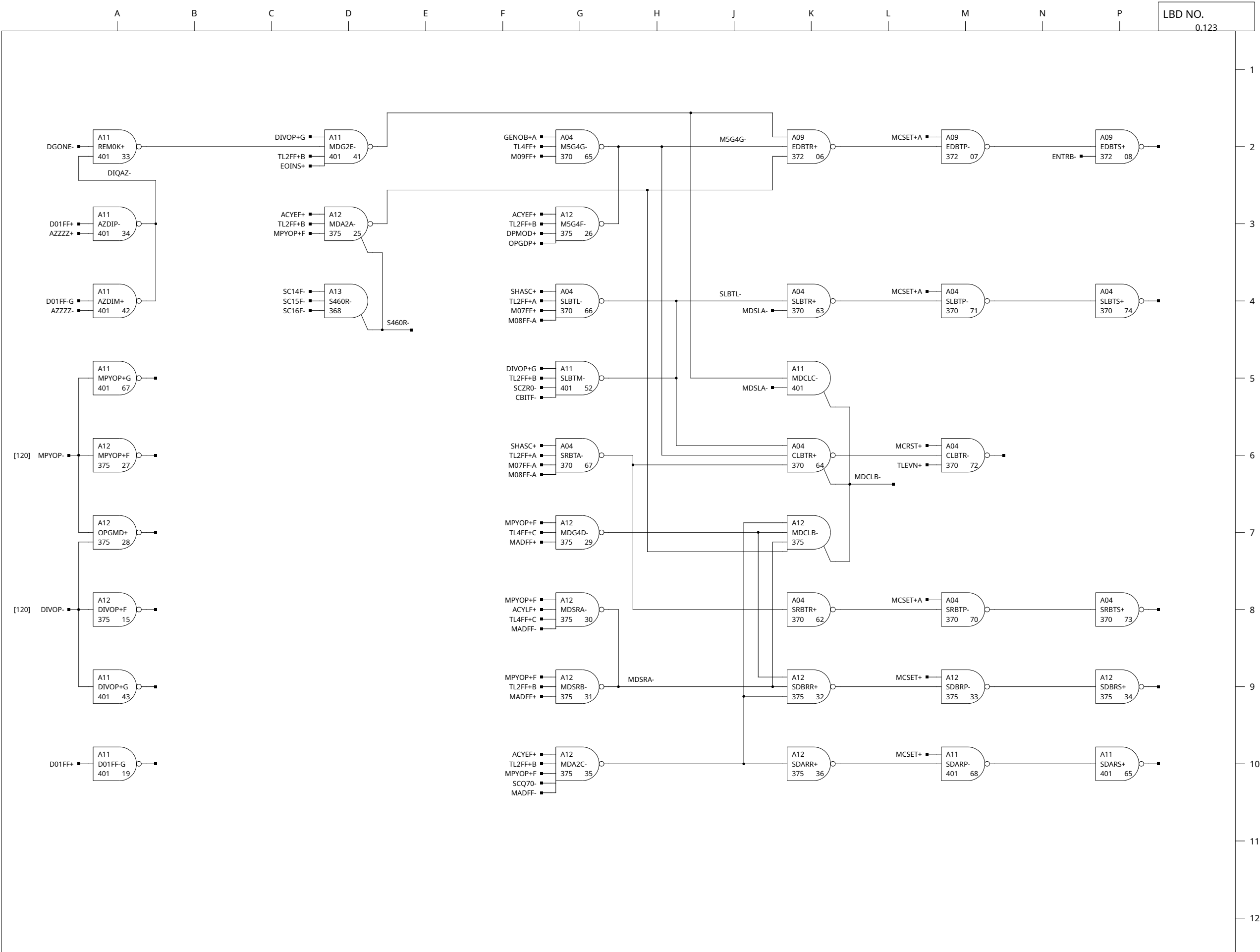

NOTES:  
 △  
 △  
 △  
 △

REV.	REVISIONS
A	
B	ECO 7748
	EXT CHANGES SEE ECO T.A.
	1/19/70

S. R. 54-3585

**HONEYWELL**  
 INC  
 COMPUTER CONTROL DIVISION  
 Old Connecticut Path, Framingham, Mass

DR. D. HAMEL	DATE
ENG. K. IZBICKI	12-26-1968
APP.	7-2-69

PROJECT NO. 55202

TITLE	H-316
	CONTROL LOGIC B
SIZE	DWG NO.
C	70024507
REV.	B

LBD NO. 0.124

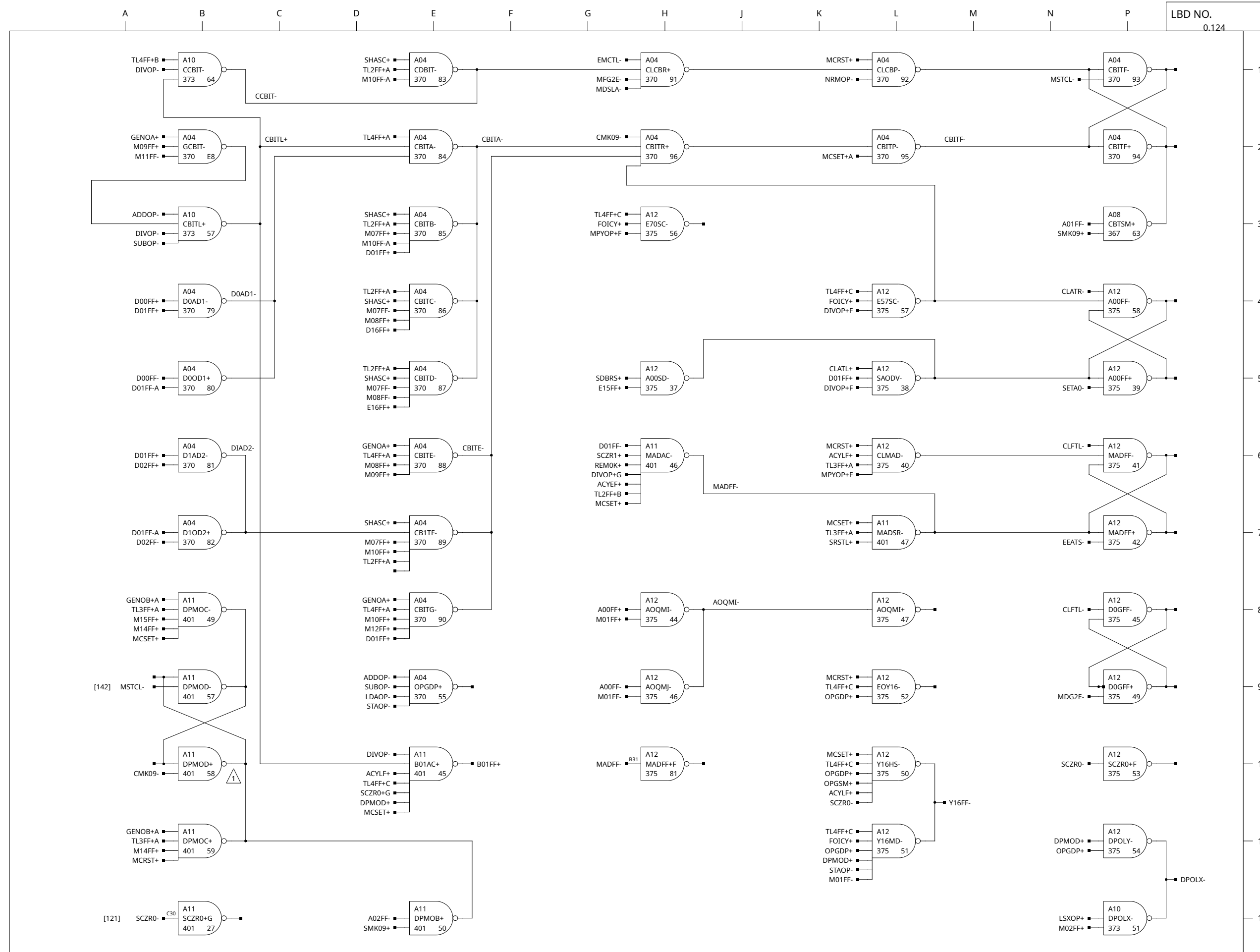

- NOTES:
- ⚠ THIS PT. IS GND WITH NO HSA OPTION
  - △
  - △
  - △
  - △

CHK.	REV.	DATE
	A	1/19/70
	B	1/19/70
S. R. 54-3585		
ECO 7748		
EXT CHANGES SEE ECO TA.		

**HONEYWELL**  
INC  
COMPUTER CONTROL DIVISION  
Old Connecticut Path, Framingham, Mass

DR. D. HAMEL	DATE
ENG. K. IZBICKI	1-13-1969
APP.	7-2-69

PROJECT NO. 55202

TITLE	H-316
	CONTROL LOGIC C
SIZE	DWG NO.
C	70024508
	REV. B



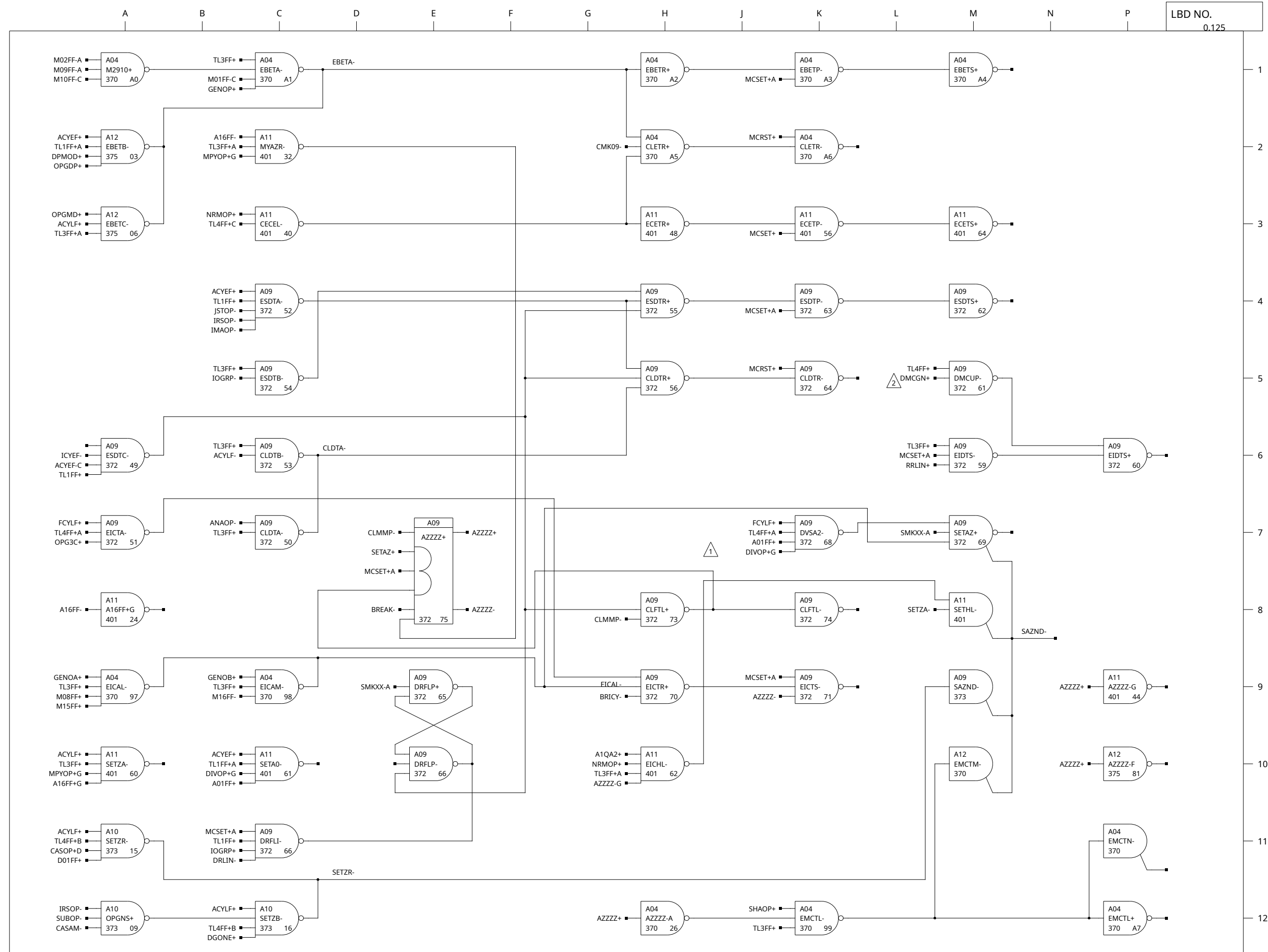

NOTES:  
 1 THIS PT. MUST BE GND WITH NO HSA OPTION.  
 2 THIS PT. TIED TO GND.

REV.	REVISED	DATE
A	ECO 7748	1/19/70
B	EXT CHANGES SEE ECO 774A	
S. R. 54-3585		

**HONEYWELL**  
 INC  
 COMPUTER CONTROL DIVISION  
 Old Connecticut Path, Framingham, Mass

DR. D. HAMEL	DATE
ENG. K. IZBICKI	12-27-1968
APP.	7-2-69

PROJECT NO. 55202

TITLE	H-316
	CONTROL LOGIC D/E
SIZE	DWG NO.
C	70024509
REV.	B

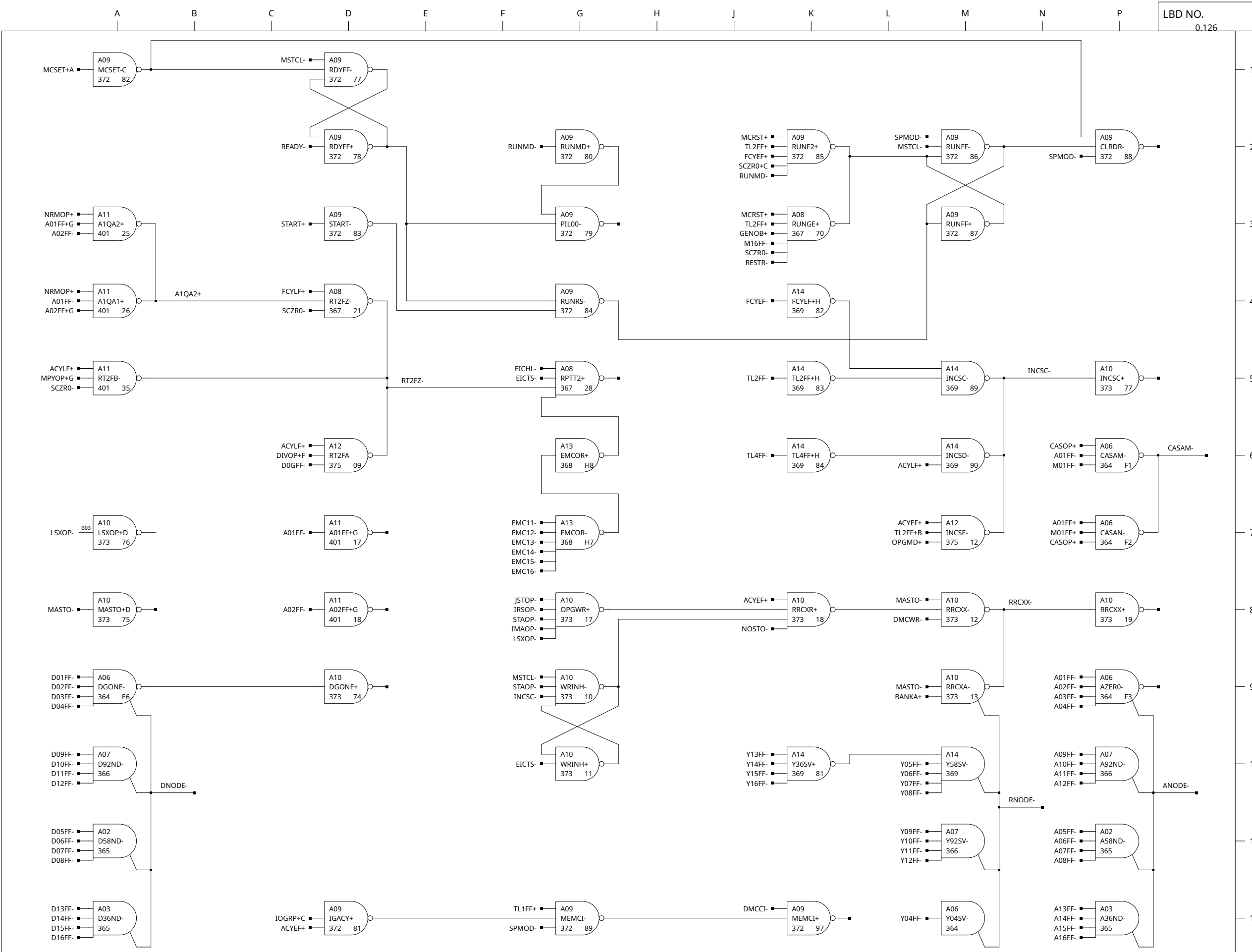

NOTES:  
 △  
 △  
 △  
 △

REV.	REVISIONS
A	
B	1/19/70
	ECO 7748
	EXT CHANGES SEE ECO 7748

S. R. 54-3585

**HONEYWELL**  
 INC  
 COMPUTER CONTROL DIVISION  
 Old Connecticut Path, Framingham, Mass

DR. D. HAMEL	DATE
ENG. K. IZBICKI	1-2-1969
APP.	7-2-69

PROJECT NO. 55202

TITLE		H-316	
CONTROL LOGIC H			
SIZE	DWG NO.	REV.	
C	70024510	B	

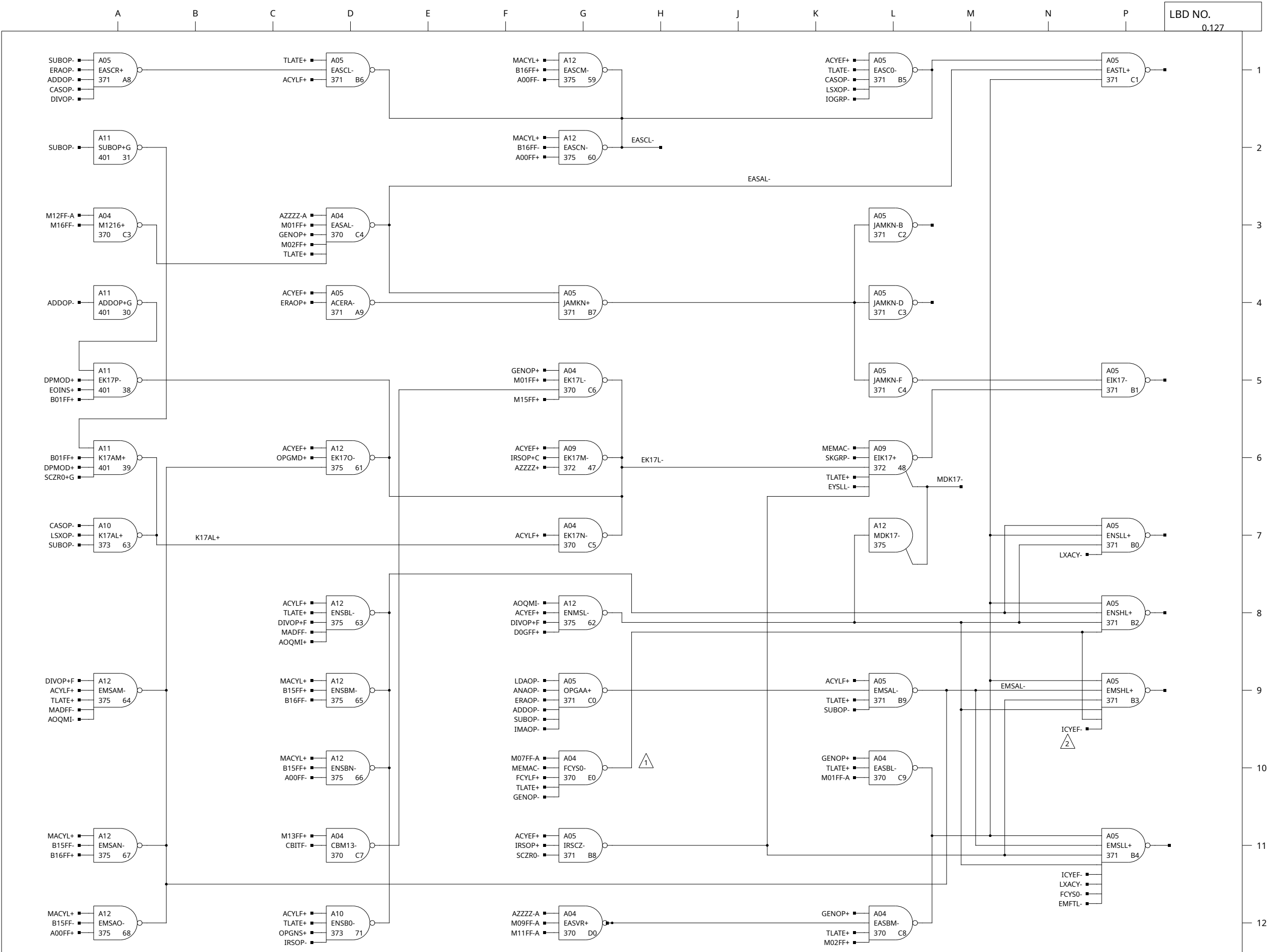

NOTES:  
 1 IF MEMORY LOCKOUT OPTION (316-08) IS INSTALLED DELETE FCYSO- FROM A1AA0526  
 2 IF MEMORY LOCKOUT OPTION (316-08) IS INSTALLED SIGNAL ICYEF- ATA1AA0528 IS REPLACED WITH ICYS1-  
 3  
 4

REV.	DESCRIPTION	DATE
A		1/19/70
B	ECO 7748	
	EXT CHANGES SEE ECO 7748	
S. R. 54-3585		
CHK.		

**HONEYWELL**  
 INC  
 COMPUTER CONTROL DIVISION  
 Old Connecticut Path, Framingham, Mass

DR. D. HAMEL	DATE
ENG. K. IZBICKI	12-31-1968
APP.	7-9-69

PROJECT NO. 55202

TITLE	H-316	CONTROL LOGIC
SIZE	DWG NO.	REV.
C	70024511	B

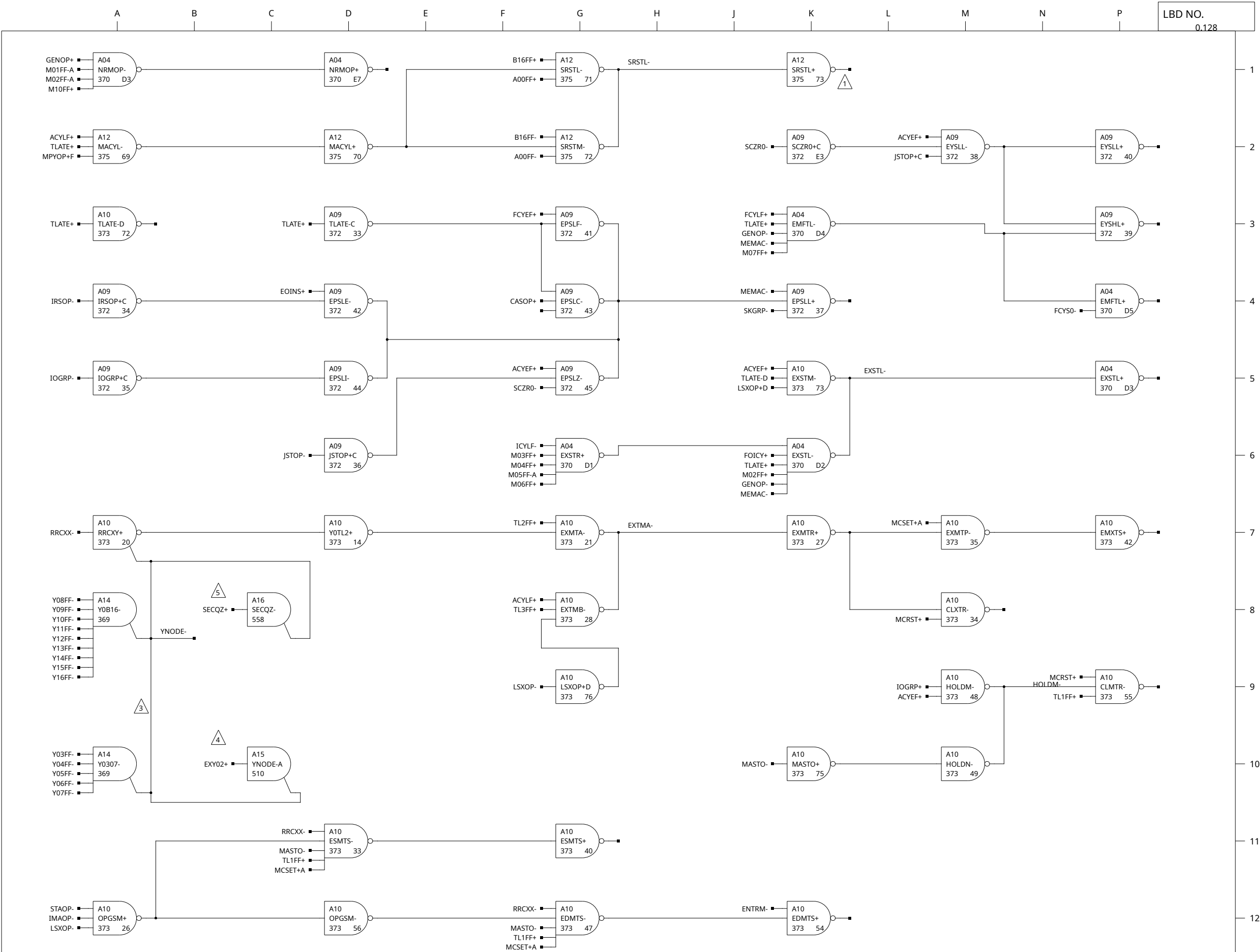

- NOTES-**
- 1 THIS PT IS TIED TO GND WITH NO HSA OPTION
  - 2 DELETE M02FF+ AND ADD M02D+ WITH EXT ADD OPTION
  - 3 DISCONNECT THIS WIRE IF MLO(316-08) IS INSTALLED
  - 4 THIS GATE INCLUDED ONLY IF MLO (316-08) IS INSTALLED

5 THIS GATE IS INCLUDED ONLY IF MLO (316-08) IS INSTALLED

REV.	REVISIONS
A	
B	1/19/70
	ECO 7748
	EXT CHANGES SEE ECO T.A.
	S. R. 54-3585

**HONEYWELL**  
 INC  
 COMPUTER CONTROL DIVISION  
 Old Connecticut Path, Framingham, Mass

DR. D. HAMEL	DATE
ENG. K. IZBICKI	12-26-1968
APP.	

PROJECT NO. 55202

TITLE	H-316	REV.	B
	CONTROL LOGIC MX	DWG NO.	70024512
SIZE	C		

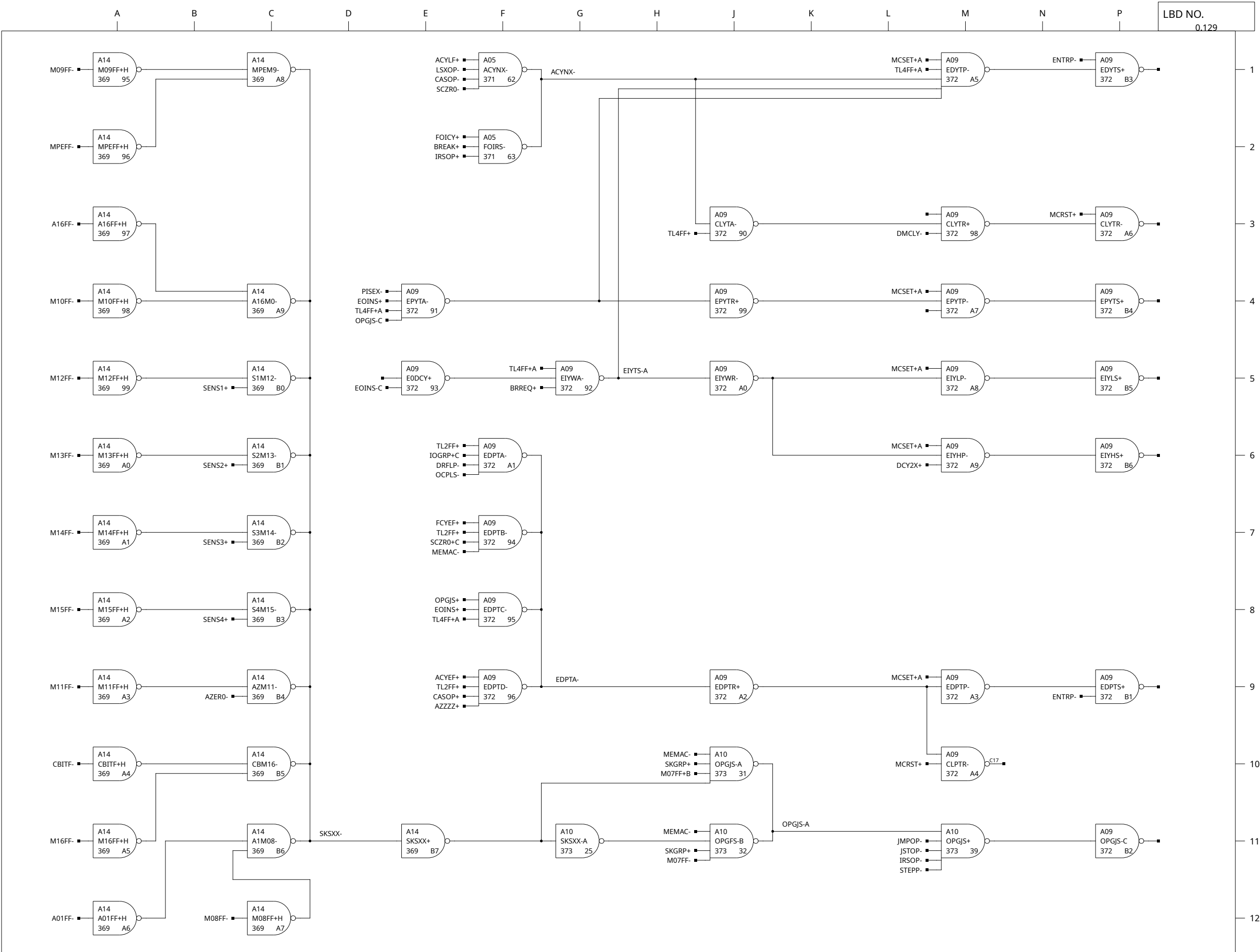

NOTES:  
 △  
 △  
 △  
 △

REV.	REVISIONS
A	
B	1/19/70
S. R. 54-3585	
ECO 7748	
EXT CHANGES SEE ECO T.A.	

**HONEYWELL**  
 INC  
 COMPUTER CONTROL DIVISION  
 Old Connecticut Path, Framingham, Mass

DR. D. HAMEL	DATE
ENG. K. IZBICKI	1-2-1969
APP.	7-2-69

PROJECT NO. 55202

TITLE	H-316
	CONTROL LOGIC PY
SIZE	DWG NO.
C	70024513
REV.	B

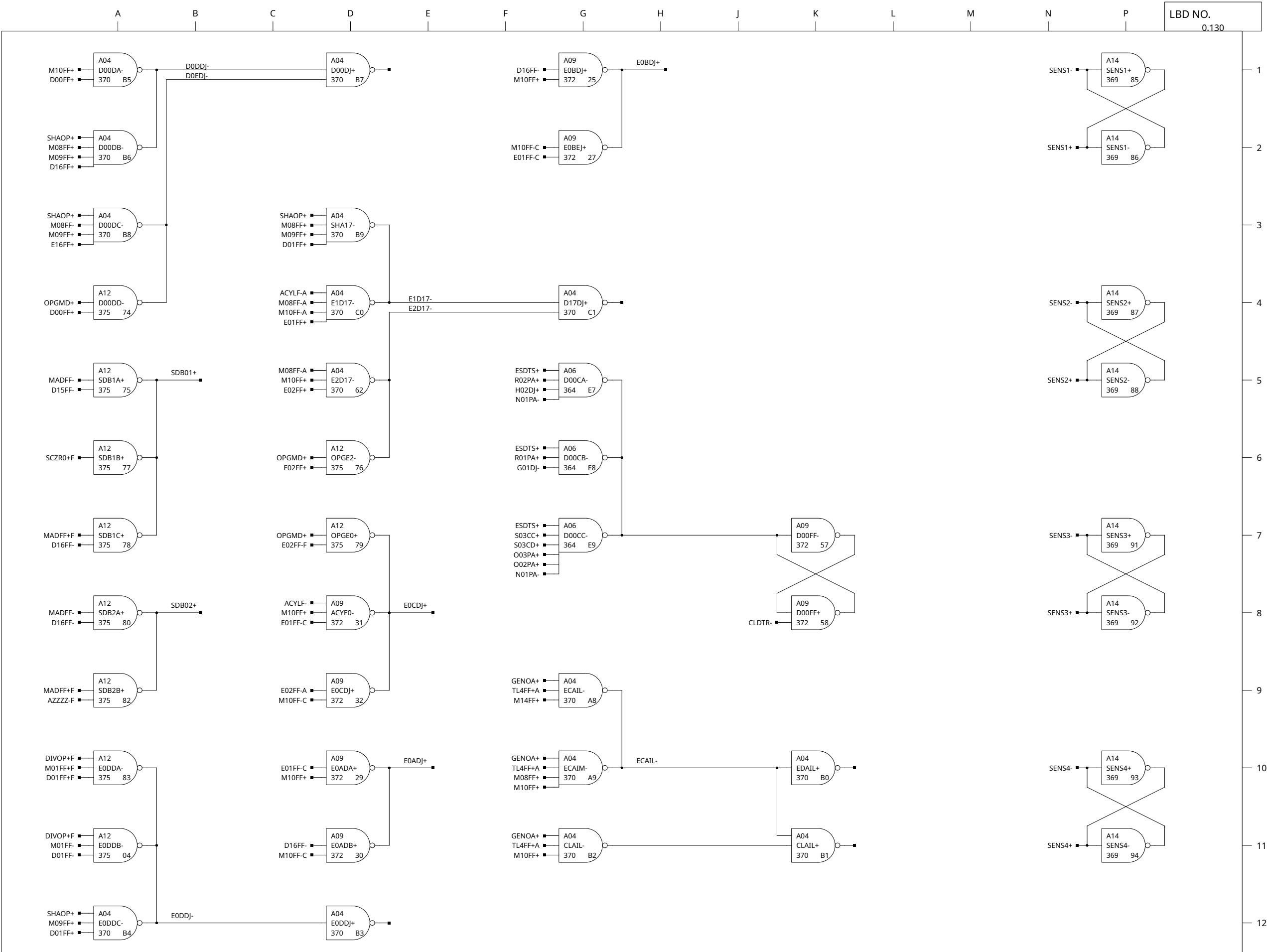

NOTES:  
 △  
 △  
 △  
 △

REV.	REVISIONS
A	
B	ECO 7/48
	EXT CHANGES SEE ECO T.A.

S. R. 54-3585

**HONEYWELL**  
 INC  
 COMPUTER CONTROL DIVISION  
 Old Connecticut Path, Framingham, Mass

DR. D. HAMEL	DATE
ENG. K. IZBICKI	1-4-1969
APP.	7-2-69

PROJECT NO. 55202

TITLE	H-316
	CONTROL LOGIC PY
SIZE	DWG NO.
C	70024514
REV.	B

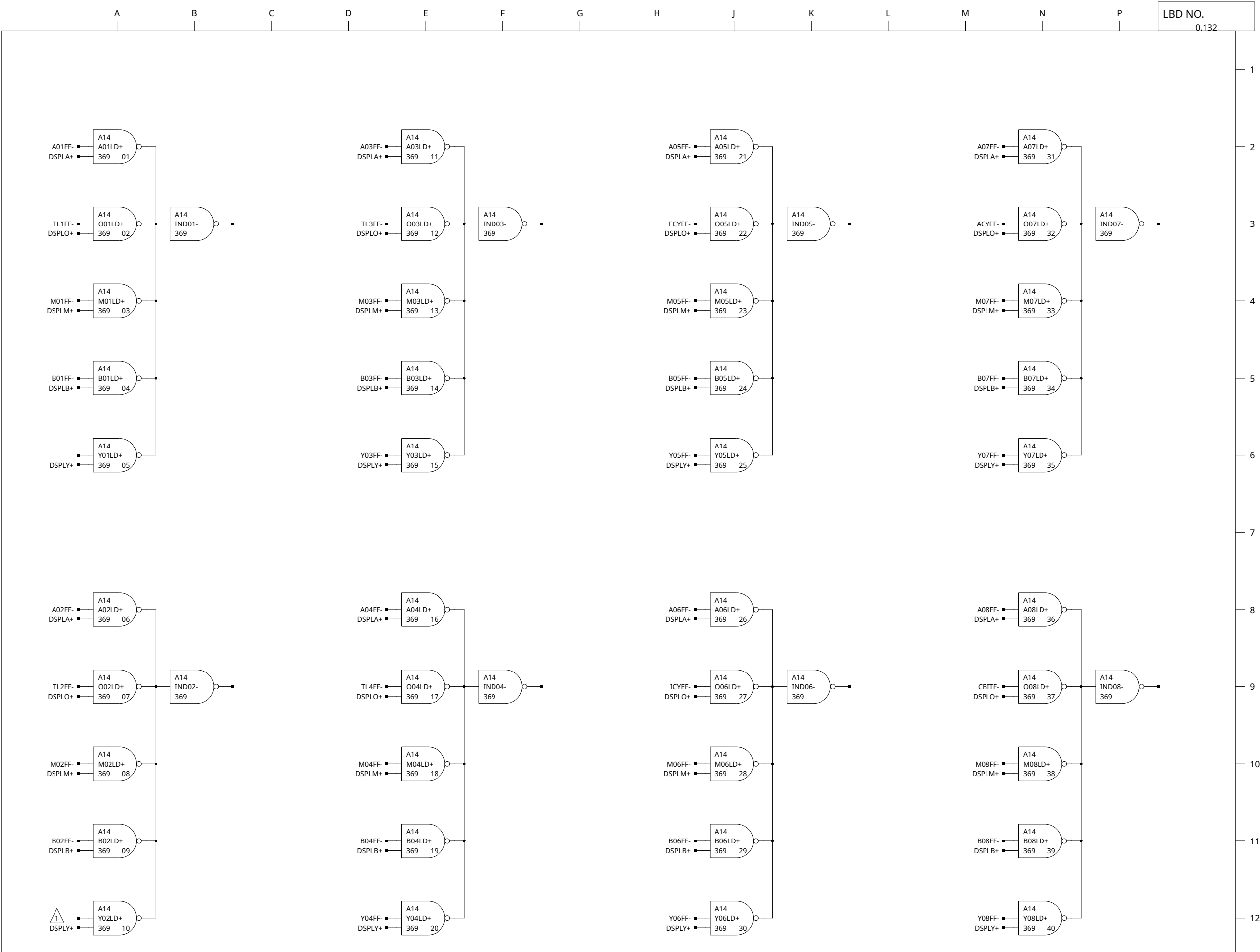

NOTES:  
 1 ADD Y02FF- WITH EXT ADD OPTION  
 2  
 3  
 4

REV.	A
REVISIONS	
CHK.	
S. R. 54-3585	
ECO 7748	1/19/70
EXT CHANGES SEE ECO T.A.	

**HONEYWELL**  
 INC  
 COMPUTER CONTROL DIVISION  
 Old Connecticut Path, Framingham, Mass

DR. D. HAMEL	DATE
ENG. K. IZBICKI	1-7-1969
APP.	
PROJECT NO. 55202	

TITLE	H-316
	LAMP DRIVER 1-8
SIZE	C
DWG NO.	70024515
REV.	B

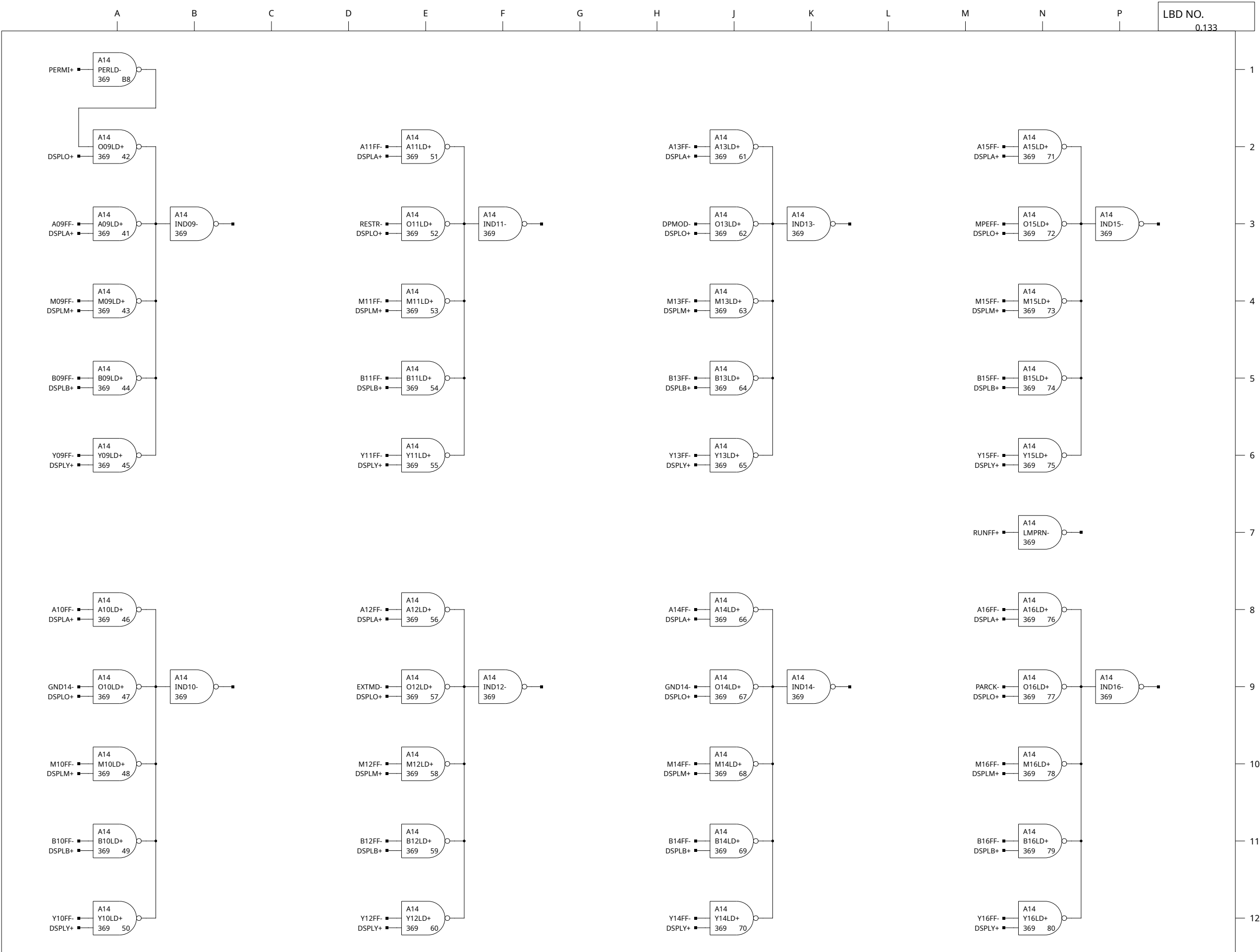

NOTES:  
 ▲  
 ▲  
 ▲  
 ▲

REV.	REVISIONS	DATE
A		
B		
C		
D		
E		
F		
G		
H		
I		
J		
K		
L		
M		
N		
O		
P		

**HONEYWELL**  
 INC  
 COMPUTER CONTROL DIVISION  
 Old Connecticut Path, Framingham, Mass

TITLE  
 H-316  
 LAMP DRIVER 9-16

DR. D. HAMEL  
 ENG. K. IZBICKI  
 APP.  
 DATE  
 1-4-1969  
 7-2-69

SIZE  
 DWG NO.  
 70024516  
 REV.  
 B

PROJECT NO. 55202

S. R. 54-3585  
 ECO 7748  
 EXT CHANGES  
 SEE ECO T.A.



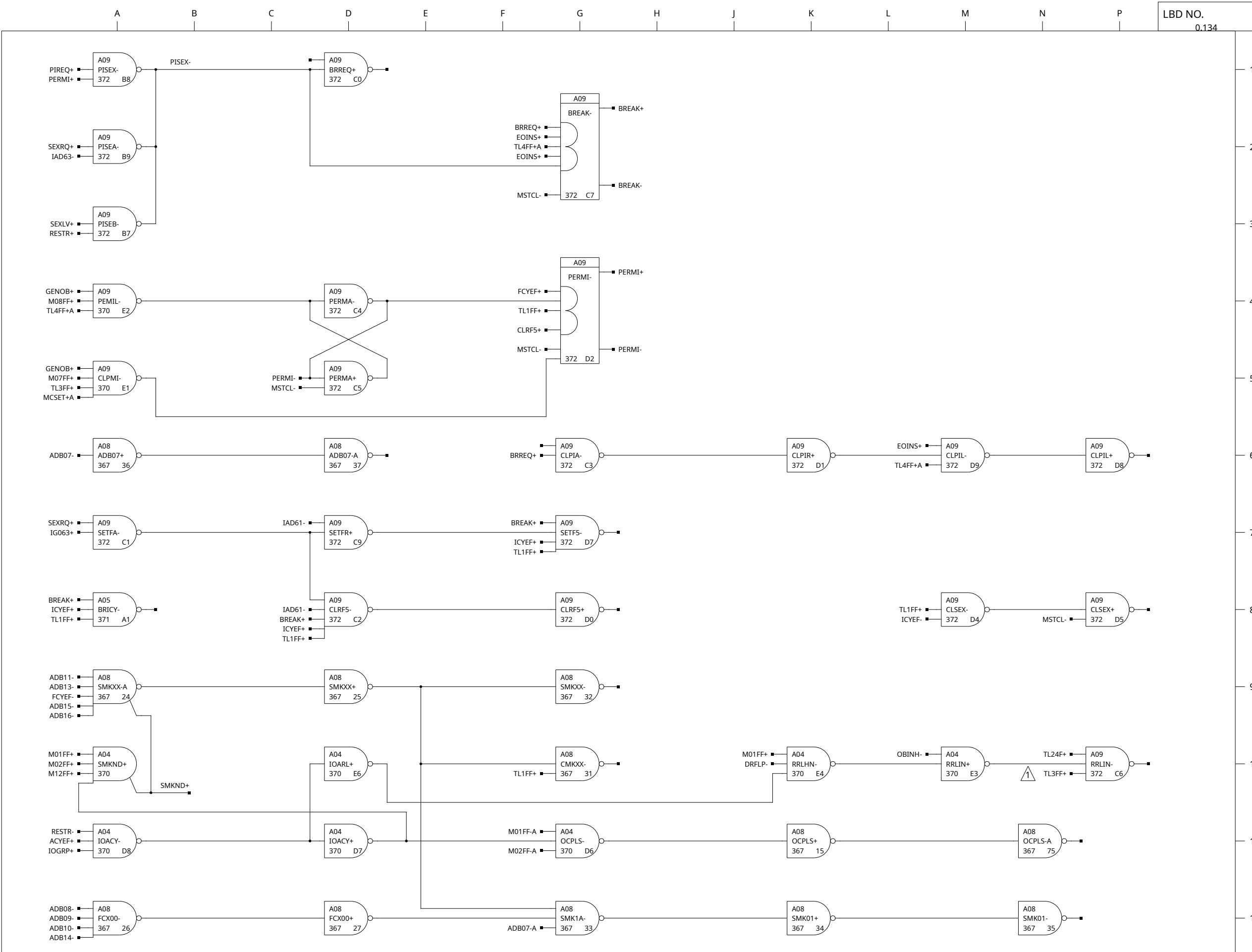

NOTES:  
 △ WITH DMC OPTION REPLACE TL3FF+ WITH DMRRL+  
 △  
 △  
 △

REV.	REVISIONS
A	
B	ECO 7227A
C	ECO 7748

S. R. 54-3585  
 EXT CHANGES SEE ECO 10/21/69  
 EXT CHANGES SEE ECO 1. A. 1/19/70

**HONEYWELL**  
 INC  
 COMPUTER CONTROL DIVISION  
 Old Connecticut Path, Framingham, Mass

DR. D. HAMEL	DATE
ENG. K. IZBICKI	1-3-1969
APP.	7-2-69

PROJECT NO. 55202

TITLE	H-316
	CONTROL LOGIC I/O
SIZE	DWG NO.
C	70024517
REV.	B

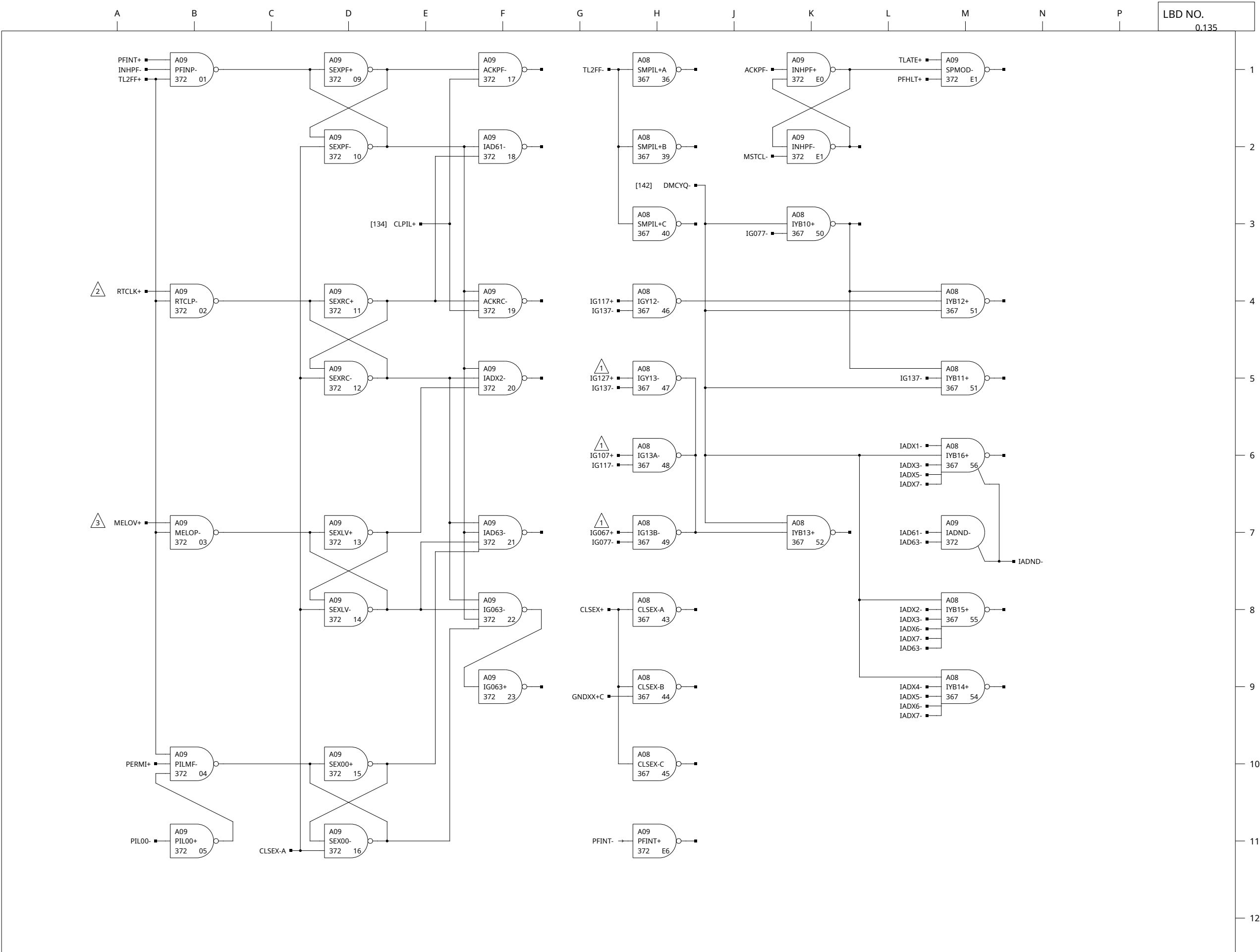

- NOTES:
- 1 THIS PT IS GND WITH NO PI OPTION
  - 2 THIS PT IS GND WITH NO RTC OPTION
  - 3 THIS PT IS GND WITH NO M.L. OPTION

REV.	REVISIONS	DATE
A		
B	ECO 7748	1/19/70
	EXT CHANGES	
	SEE ECO 7748	

S. R. 54-3585

**HONEYWELL**  
INC  
COMPUTER CONTROL DIVISION  
Old Connecticut Path, Framingham, Mass

DR. J. D. GILMARTIN	DATE
ENG. K. IZBICKI	1-9-1969
APP.	7-2-69

PROJECT NO. 55202

TITLE	H-316
	INTERRUPT ADDRESS ENCODING
SIZE	DWG NO.
C	70024518
REV.	B

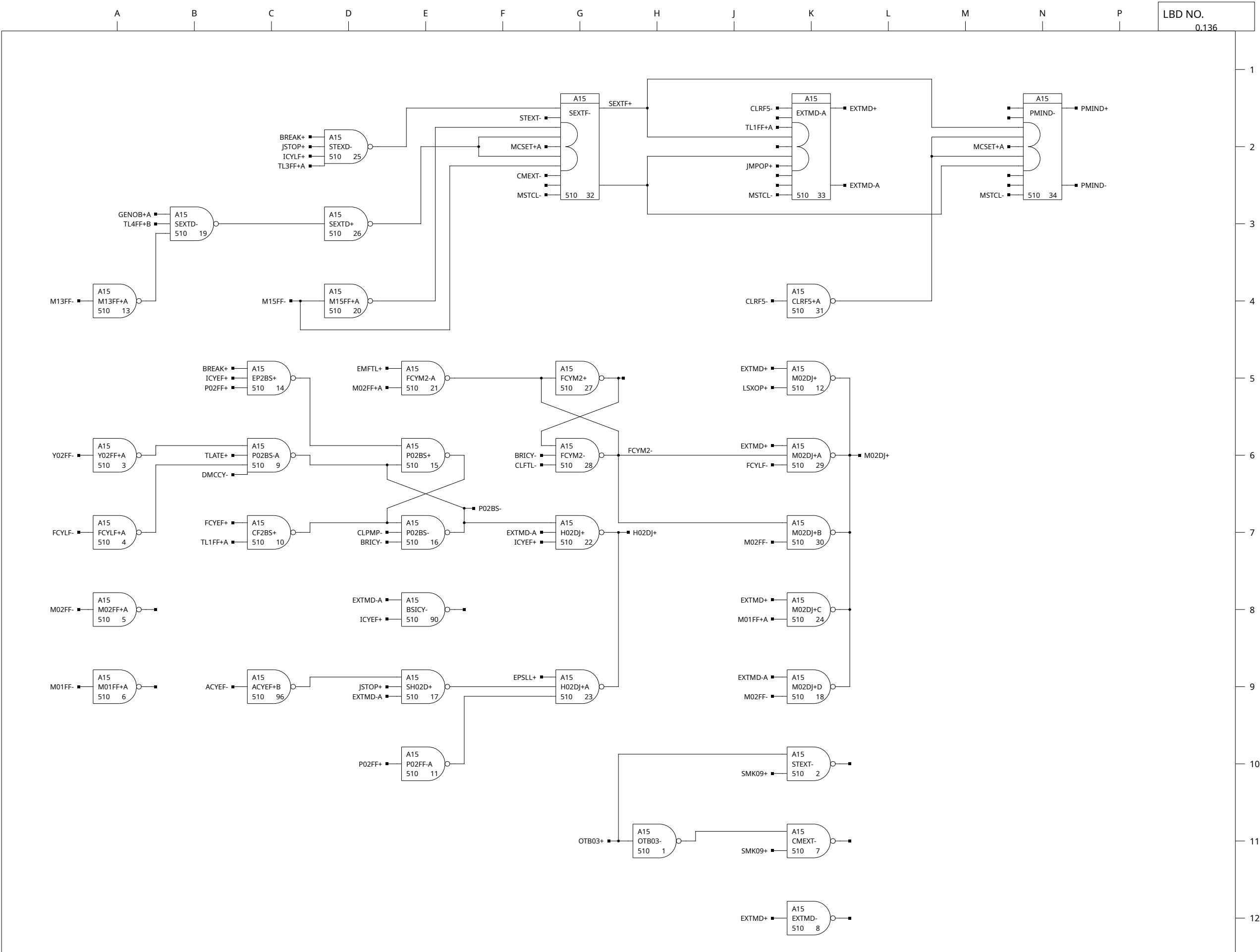

NOTES:  
 △  
 △  
 △  
 △

REV.	REVISIONS	DATE
1	A	

S. R. 54-3915

CHK.	REV.	DATE

**HONEYWELL**  
 INC  
 COMPUTER CONTROL DIVISION  
 Old Connecticut Path, Framingham, Mass

DR. D. HAMEL	DATE
ENG. R. ALBRIGHT	5-16-1969
APP.	

PROJECT NO. 53217

TITLE	H-316
	MEMORY EXPANSION
	CONTROL LOGIC
SIZE	DWG NO.
C	70025829
REV.	A

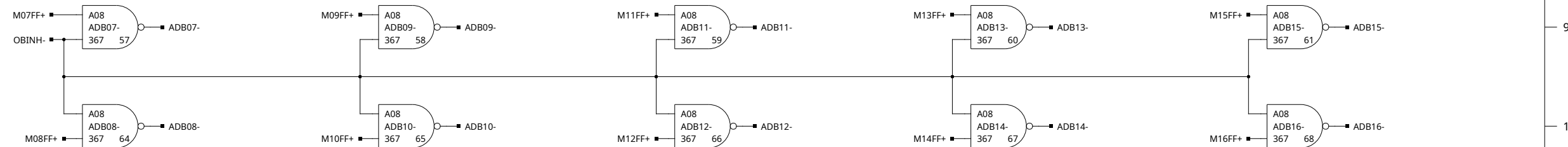
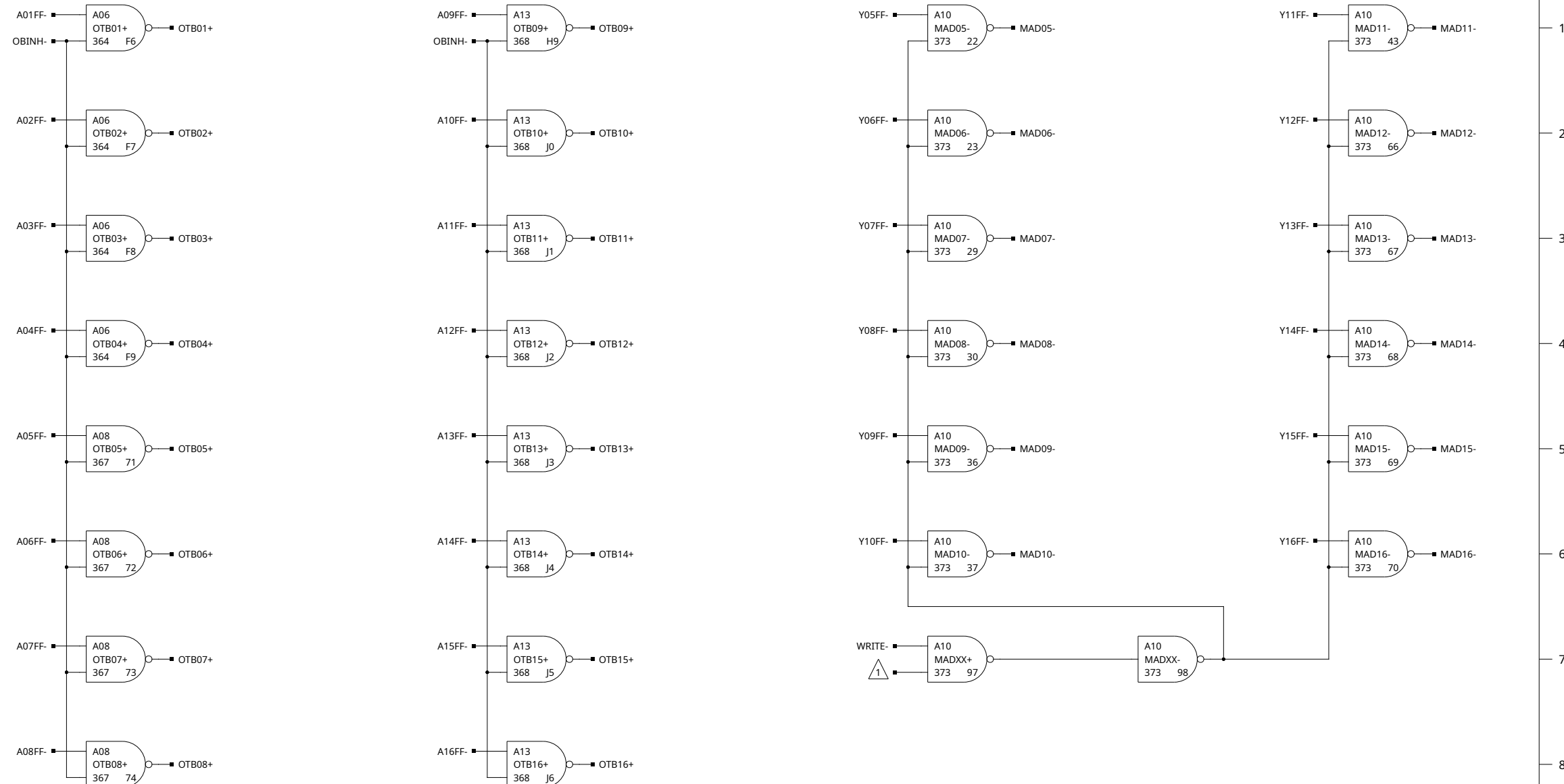

NOTES:  
 ⚠️ ADD Y02FF- WITH EXT. ADD OPTION  
 ⚠️  
 ⚠️  
 ⚠️

REV.	REVISIONS
A	
B	

S. R. 54-3585  
 ECO 7748  
 EXT CHANGES SEE ECO T.A.

**HONEYWELL**  
 INC  
 COMPUTER CONTROL DIVISION  
 Old Connecticut Path, Framingham, Mass

DR. D. HAMEL	DATE
ENG. K. IZBICKI	1-13-1969
APP.	7-2-69

PROJECT NO. 55202

TITLE  
 H-316  
 OUTPUT BUSES

SIZE	DWG NO.	REV.
C	70024519	B

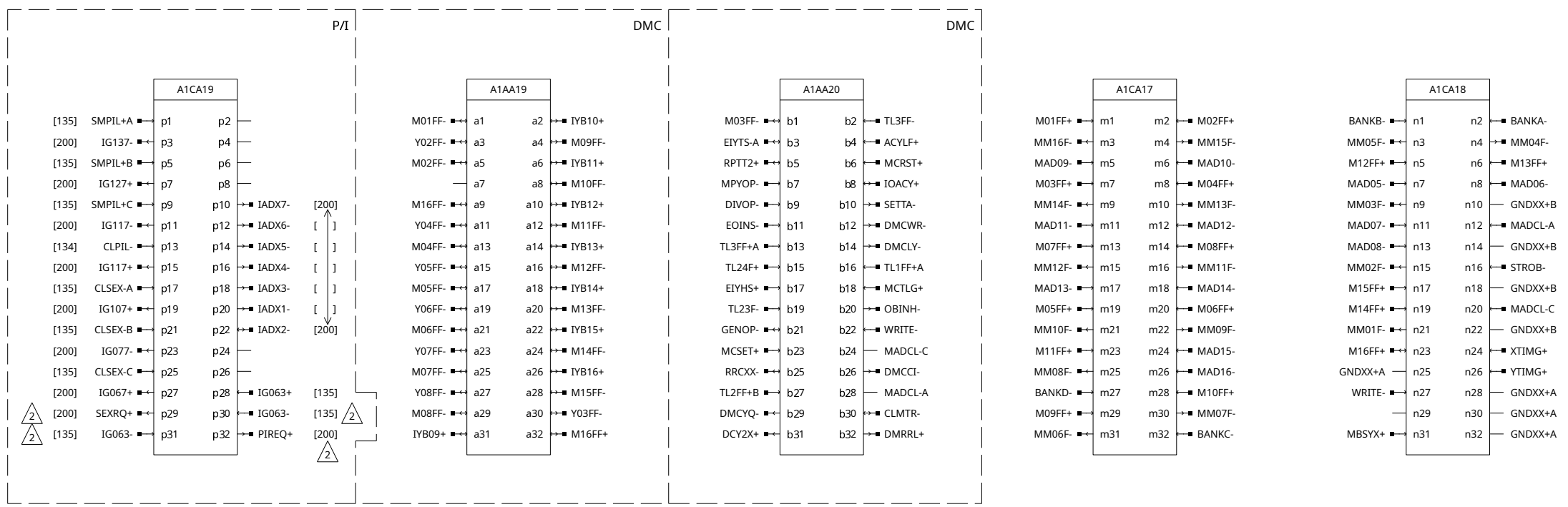
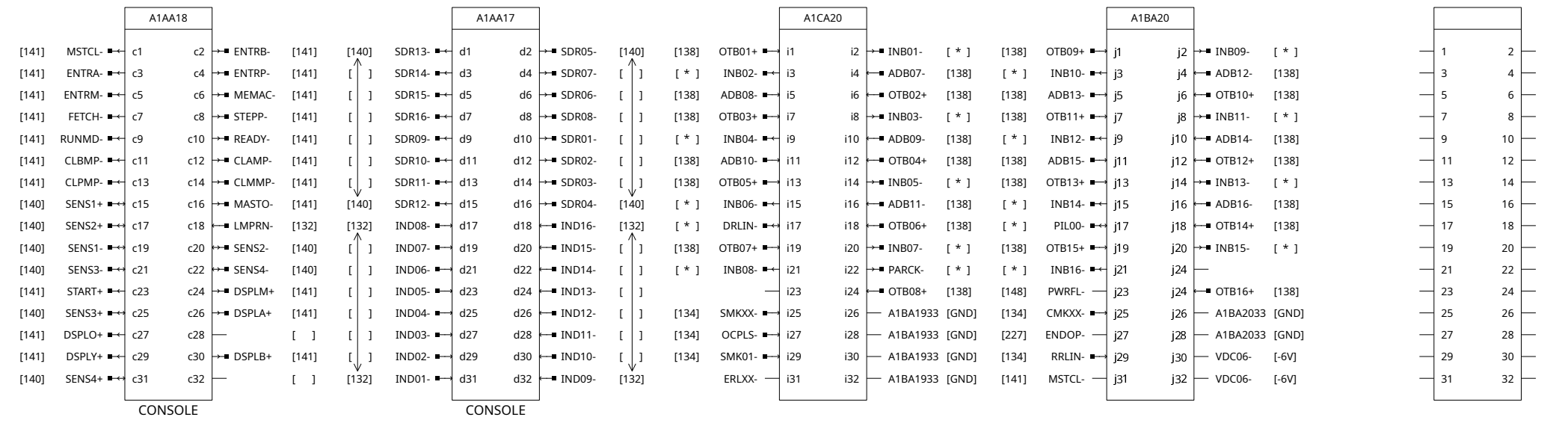

NOTES:  
 △ \* THESE SIGNALS ARRIVE BY BUS FROM I/O OPTIONS, DEPENDING ON SYSTEM CONFIGURATION  
 △ WITH NO PI TIE SEXRQ+ AND PIREQ+ TO IG063-  
 △  
 △

REV.	REVISIONS
A	
B	

S. R. 54-3585  
 ECO 7227A  
 EXT CHANGES SEE ECO 7021/69

**HONEYWELL**  
 INC  
 COMPUTER CONTROL DIVISION  
 Old Connecticut Path, Framingham, Mass

DR. D. HAMEL	DATE
ENG. K. IZBICKI	1-20-1969
APP.	7-2-69

PROJECT NO. 55202

TITLE	H-316
CONSOLE AND I/O CONNECTORS	
SIZE	DWG NO.
C	70024523
REV.	B

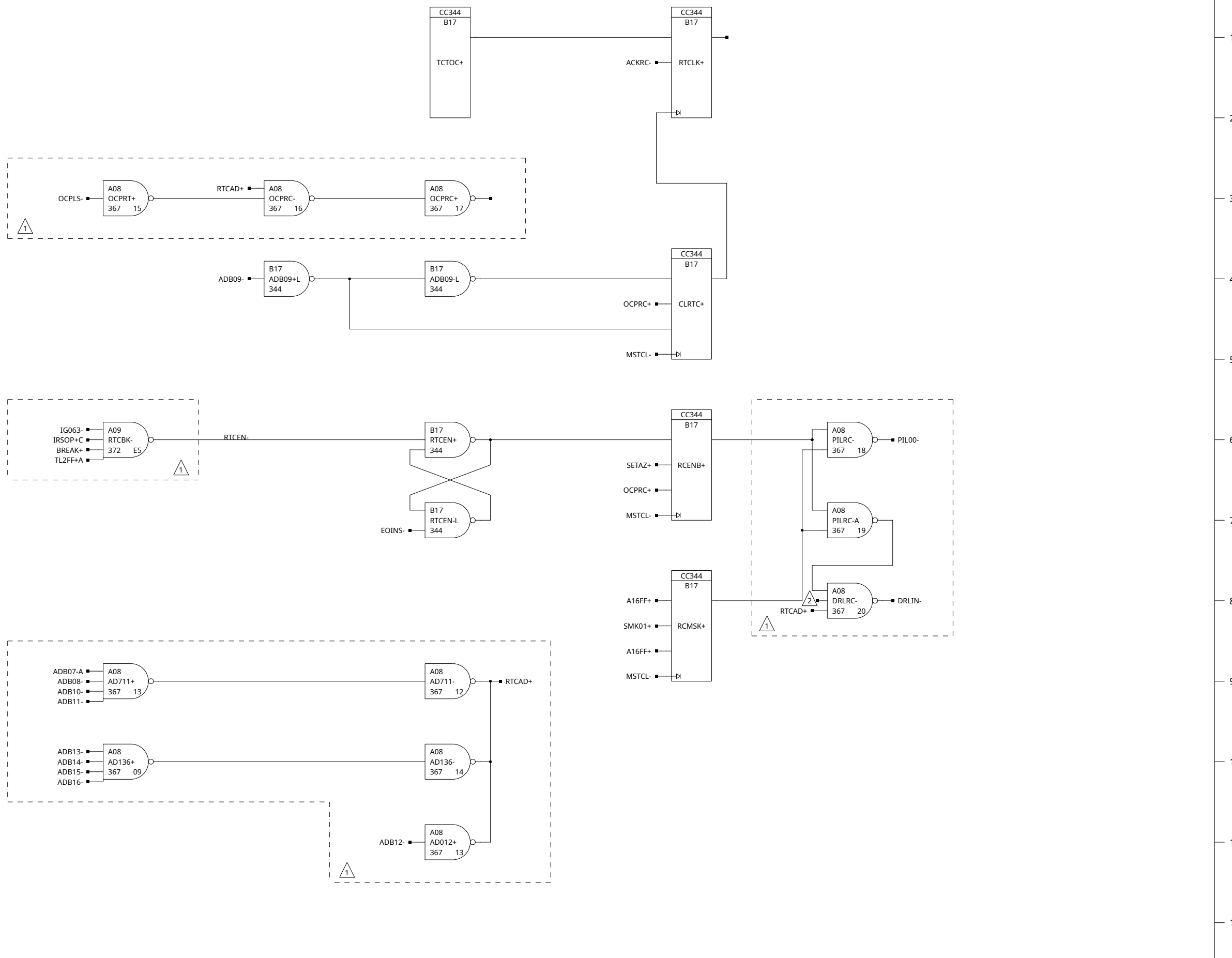

- NOTES:
- 1 THESE CIRCUITS ALSO SHOWN ON L.B.D. 0.119
  - 2 REMOVE GND WHEN USING RTC

CHK.	REV.	REVISIONS	DATE
	A		1/19/70
	B	ECO7748	1/19/70
		SEE CHANGES	
		SEE ECU/TA	

S. R. 54-3585

**HONEYWELL**  
INC  
COMPUTER CONTROL DIVISION  
Old Connecticut Path, Framingham, Mass

DR. D. HAMEL	DATE
ENG. K. IZBICKI	2-27-69
APP.	4/10/69

PROJECT NO. 55202

TITLE	H-316-12	REAL TIME CLOCK
SIZE	DWG NO.	REV.
C	70024524	B

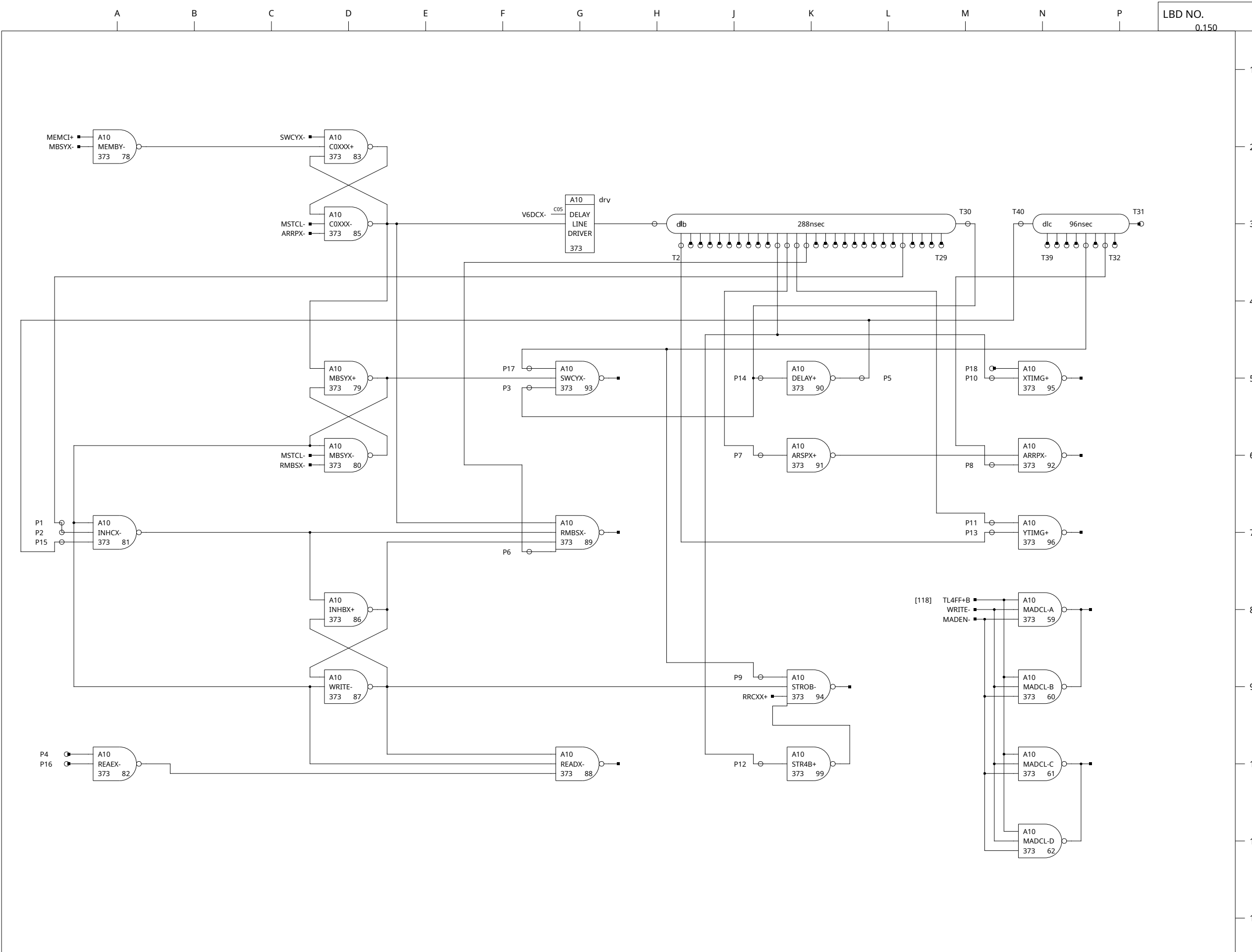

NOTES:  
 △  
 △  
 △  
 △

REV.	REVISIONS
A	
B	
C	
D	
E	
F	
G	
H	
J	
K	
L	
M	
N	
P	

S. R. 54-3585  
 ECO 7748  
 EXT CHGS  
 SEE ECOT. J.

**HONEYWELL**  
 INC  
 COMPUTER CONTROL DIVISION  
 Old Connecticut Path, Framingham, Mass

DR. D. HAMEL	DATE
ENG. K. IZBICKI	1-21-1969
APP.	7-2-69

PROJECT NO. 55202

TITLE	H-316
	TIMING & CONTROL
SIZE	DWG NO.
C	70024529
REV.	B

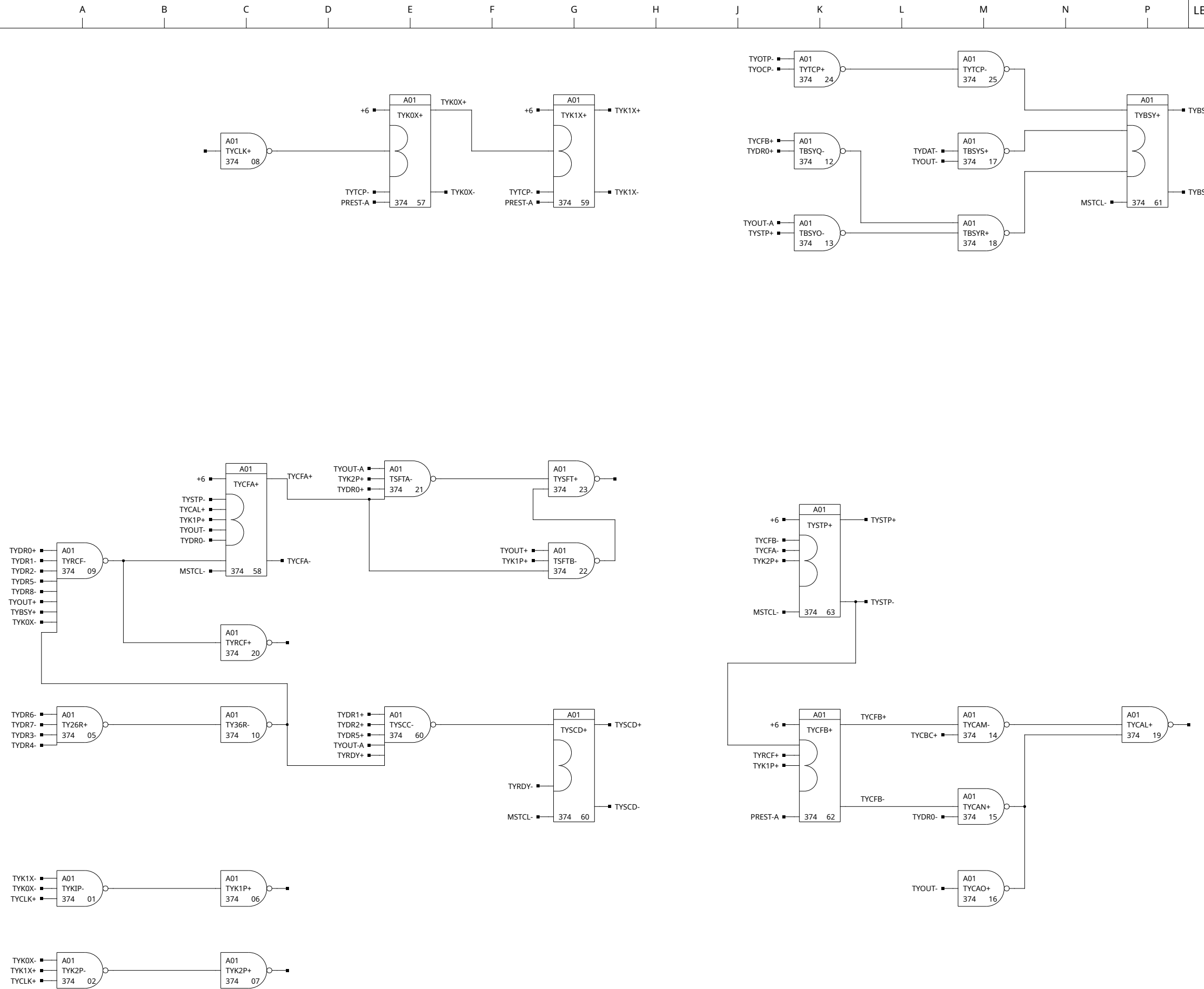

- NOTES:
- △
  - △
  - △
  - △

CHK.	REV.	REVISIONS	REV.
			A
S. R. 54-3585			

**HONEYWELL**  
INC  
COMPUTER CONTROL DIVISION  
Old Connecticut Path, Framingham, Mass

DR. D. HAMEL	DATE
ENG. K. IZBICKI	1-9-1969
APP.	4-10-69
PROJECT NO. 53202	

TITLE		H-316	
		ASR 33/35	
		CONTROL	
SIZE	DWG NO.	REV.	
C	70024526	A	



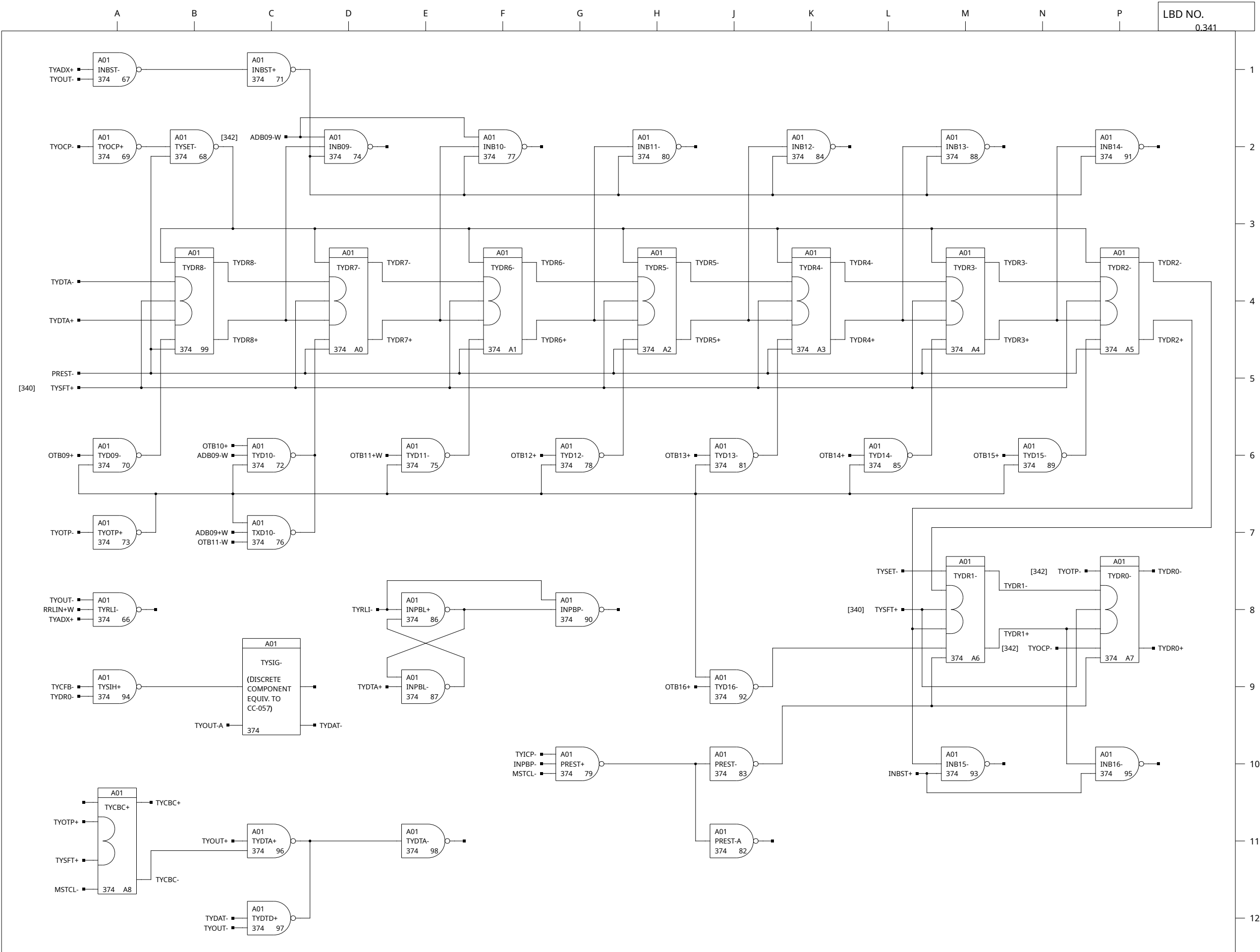

NOTES:  
 ▲  
 ▲  
 ▲  
 ▲

REV.	REVISIONS
A	
B	ECO 7748 EXT CHANGES SEE ECO 7748
1/19/70	
S. R. 54-3585	

**HONEYWELL**  
 INC  
 COMPUTER CONTROL DIVISION  
 Old Connecticut Path, Framingham, Mass

DR. D. HAMEL	DATE
ENG. K. IZBICKI	1-8-1969
APP.	4-10-69
PROJECT NO. 53202	

TITLE	H-316 -56
	BUFFER REGISTER
	ASR 33/35
SIZE	DWG NO. 70024527
REV.	B

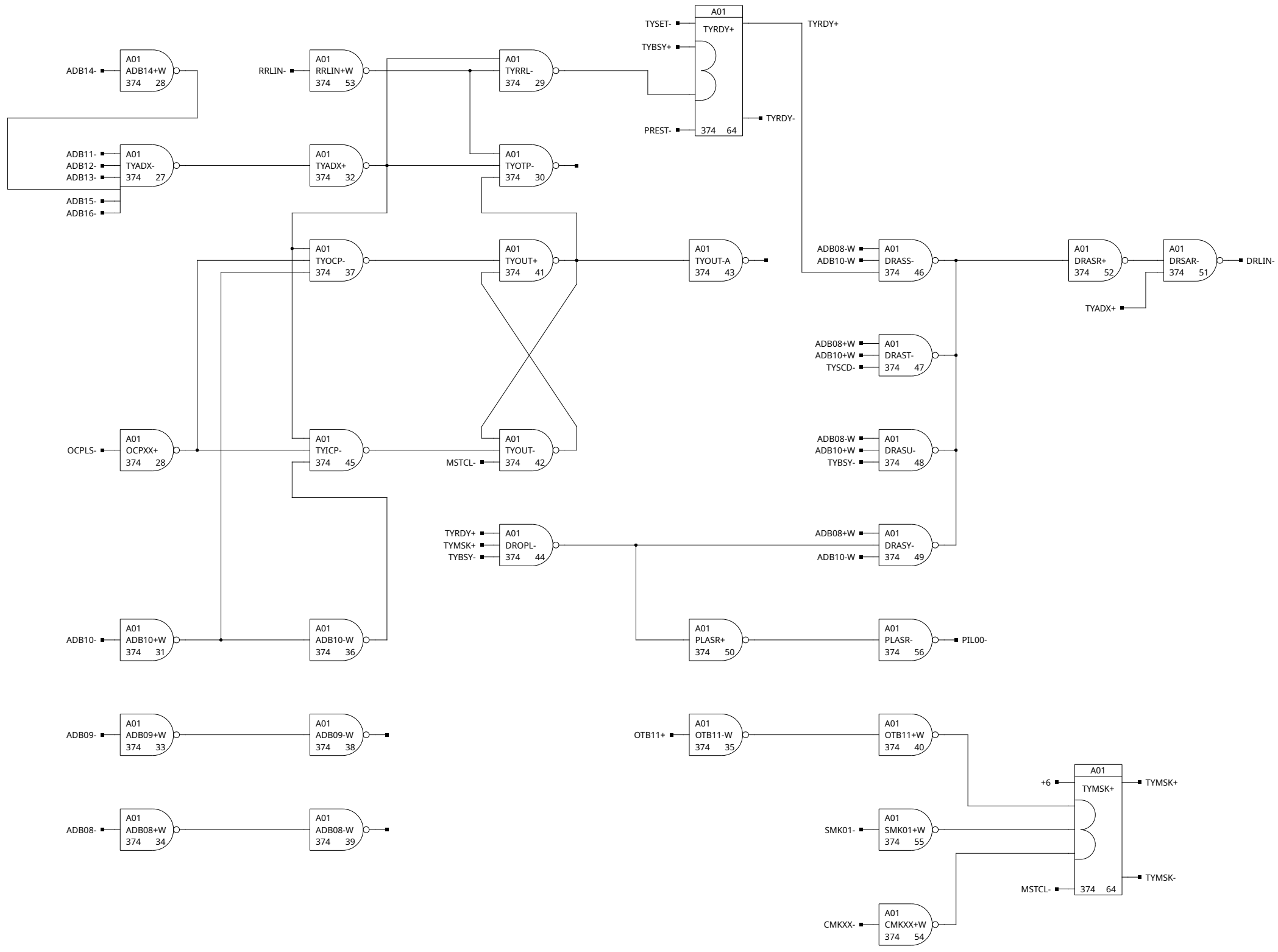

NOTES:  
 △  
 △  
 △  
 △

REV.	REV. NO.	DATE	BY	CHK.
A				

**HONEYWELL**  
 INC  
 COMPUTER CONTROL DIVISION  
 Old Connecticut Path, Framingham, Mass

DR. J.D. GILMARTIN  
 ENG. K. IZBIKCI  
 APP. \_\_\_\_\_

DATE  
 1-8-1969  
 4-10-69

PROJECT NO. 53202

TITLE H-316 ADDRESS & SKS ASR 33/35	SIZE C	DWG NO. 70024528	REV. A
--	-----------	---------------------	-----------

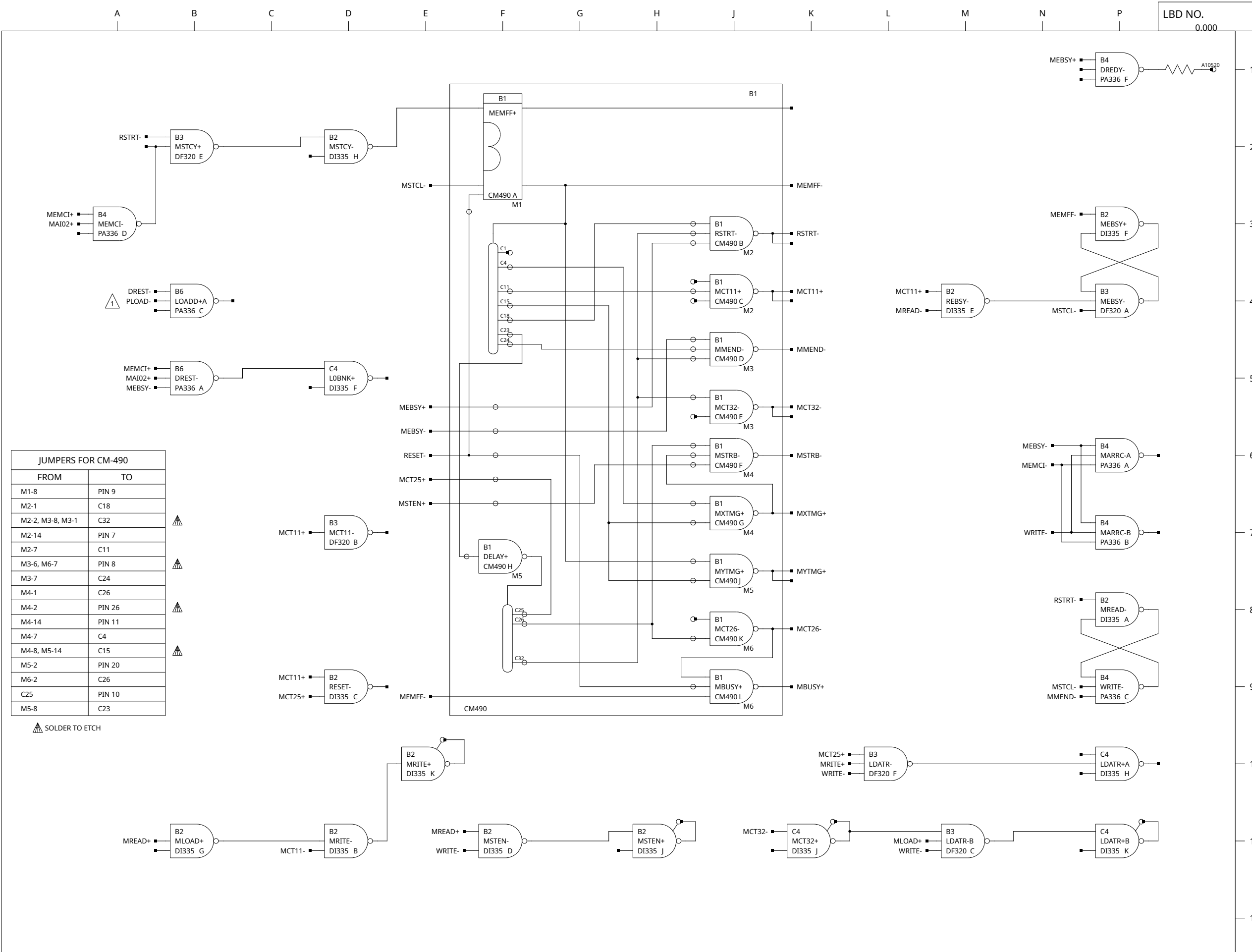

**JUMPERS FOR CM-490**

FROM	TO
M1-8	PIN 9
M2-1	C18
M2-2, M3-8, M3-1	C32
M2-14	PIN 7
M2-7	C11
M3-6, M6-7	PIN 8
M3-7	C24
M4-1	C26
M4-2	PIN 26
M4-14	PIN 11
M4-7	C4
M4-8, M5-14	C15
M5-2	PIN 20
M6-2	C26
C25	PIN 10
M5-8	C23

▲ SOLDER TO ETCH

- NOTES:**
- ▲ SOURCE FOR SIGNAL PLOAD- IS MEMORY PARITY WHEN INSTALLED
  - ▲
  - ▲
  - ▲

CHK.	REVISIONS	REV.	A

S. R. 54-3915

ECO	8536	B
EXT. CHGS SEE ECO	7/2/70	A.K.
ECO	9490	C
EXT. CHGS SEE ECO	6/4/71	A.K.
ECO	20687	D
CHG'D PER ECO	12/11/72	T.L.B.
ECO	30162	E
SEE ECO	7/3/79	T.L.B.

**HONEYWELL**  
INC  
COMPUTER CONTROL DIVISION  
Old Connecticut Path, Framingham, Mass

DR. D. HAMEL	DATE
ENG. R. ALBRIGHT	5/15/69
APP.	9/12/69

PROJECT NO. 53217

TITLE	H-316
	MEMORY EXPANSION
	MEMORY TIMING & CONTROL
SIZE	DWG NO.
C	70025825
REV.	E

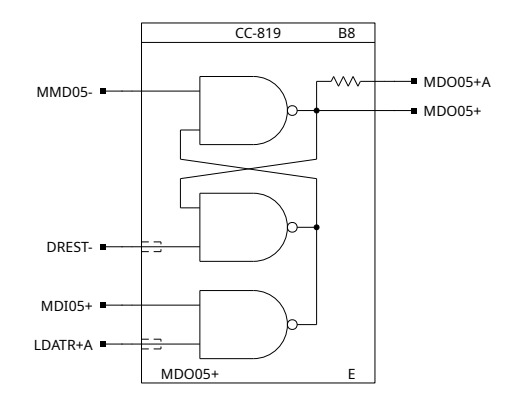
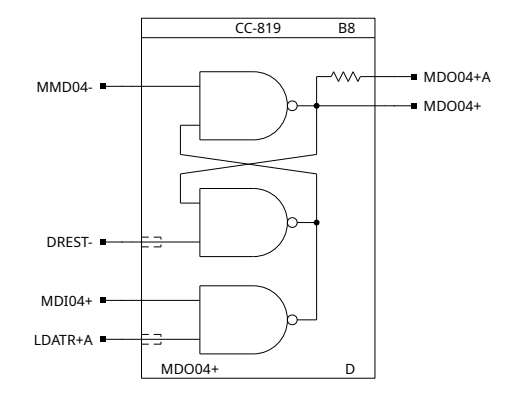
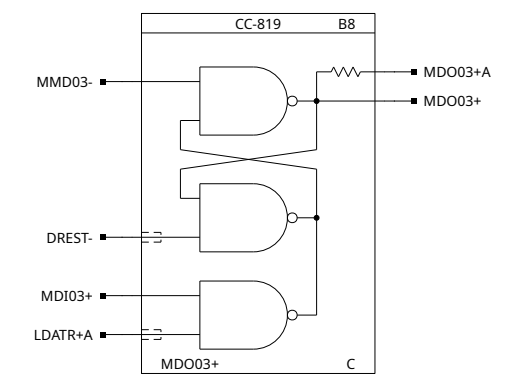
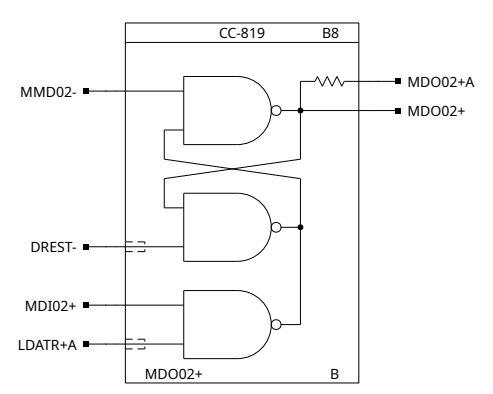
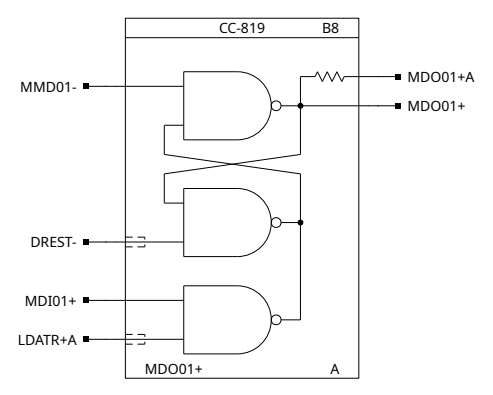
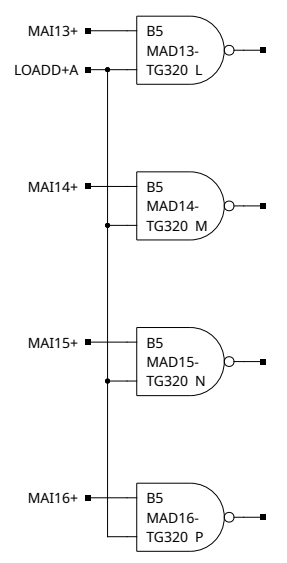
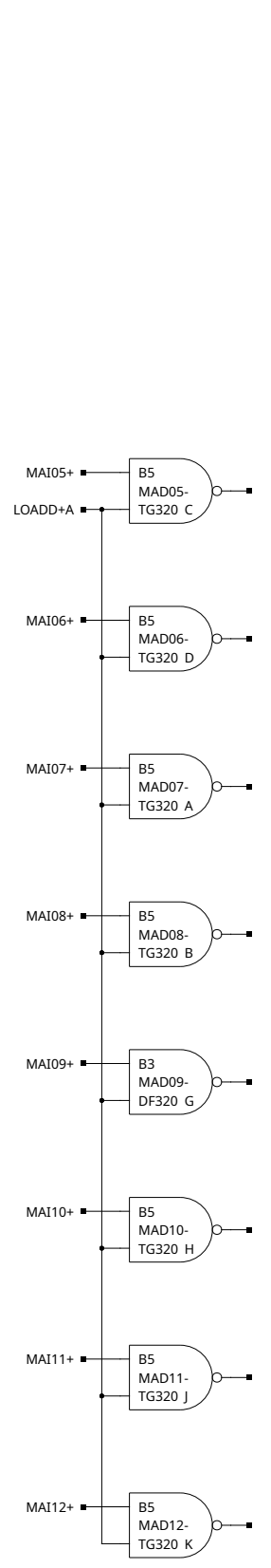

NOTES:  
△  
△  
△  
△

CHK.	REVISIONS	REV.
		A
	S. R. 54-3915	
	ECO 8458	B
	EXT. CHGS SEE ECO 3/27/70 A.K.	
	ECO 9617	C
	SEE ECO 7/2/71 SSR	
	ECO 20687	D
	SEE ECO 12/13/72 12/27 I.L.B.	
	12/27/72	

**HONEYWELL**  
INC  
COMPUTER CONTROL DIVISION  
Old Connecticut Path, Framingham, Mass

DR. D. HAMEL	DATE
ENG. R. ALBRIGHT	5/13/69
APP.	

PROJECT NO. 53217

TITLE  
H-316  
MEMORY EXPANSION  
ADDRESS GATING & DATA  
REGISTER BITS 1-5

SIZE	DWG NO.	REV.
C	70025828	D

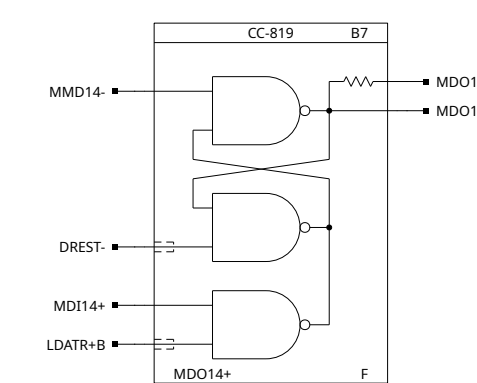
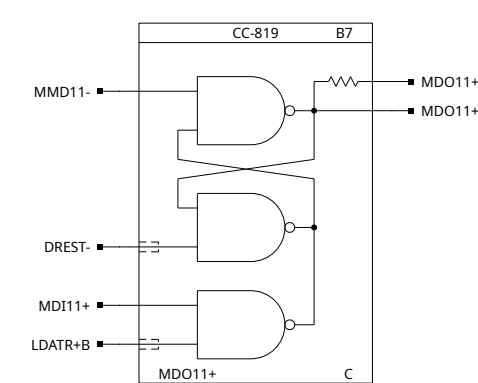
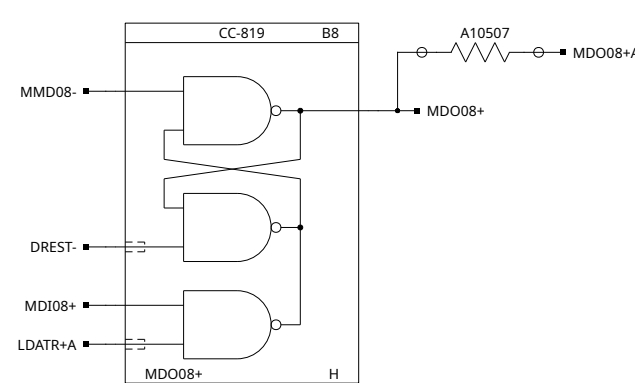
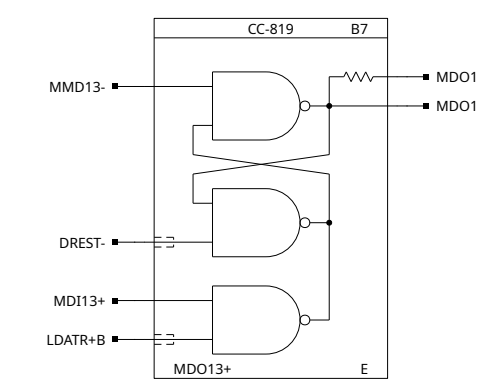
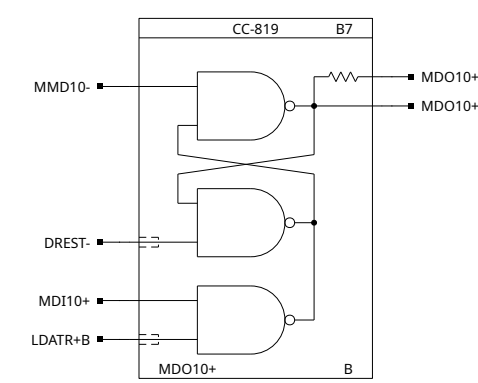
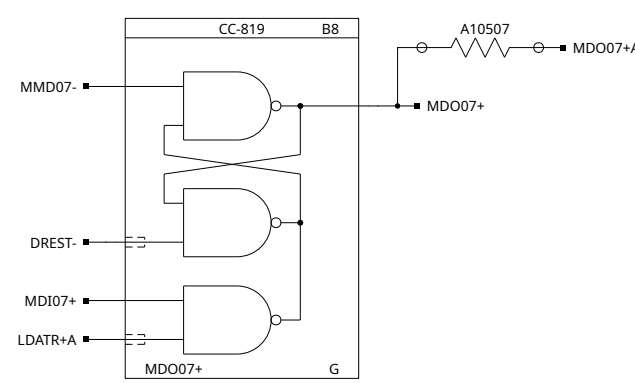
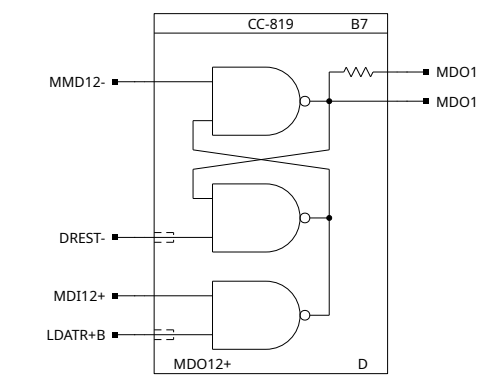
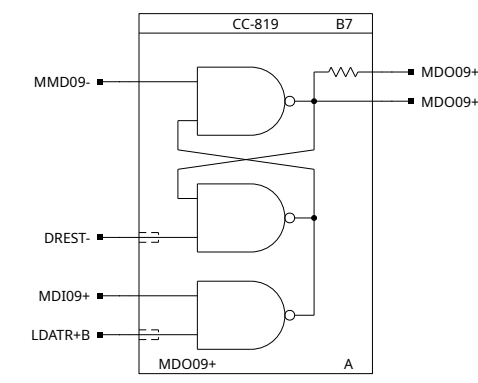
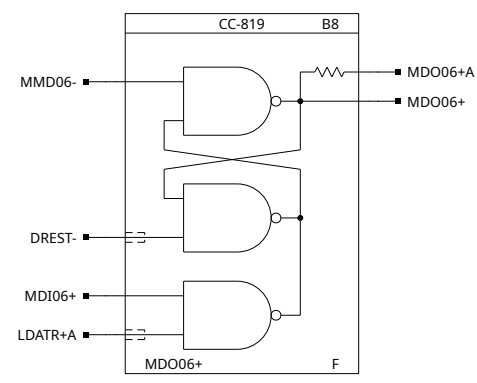

NOTES:  
 △  
 △  
 △  
 △

CHK.	REVISIONS	REV.
		A
	S. R. 54-3915	
	ECO 8458	B
	EXT. CHGS SEE ECO 3/27/70 A.K.	
	ECO 9490	C
	EXT. CHGS SEE ECO 6/4/71 A.K.	
	ECO 9617	D
	SEE ECO	
	7/2/71	SSR
	ECO 20687	E
	SEE ECO 12/14/72 12/27 T.L.B.	

**HONEYWELL**  
 INC  
 COMPUTER CONTROL DIVISION  
 Old Connecticut Path, Framingham, Mass

DR. D. HAMEL	DATE
ENG. R. ALBRIGHT	5/13/69
APP.	9/12/69

PROJECT NO. 53217

TITLE	H-316-0602
	MEMORY EXPANSION
	DATA REGISTER BITS 6-14
SIZE	DWG NO.
C	70025834
REV.	E

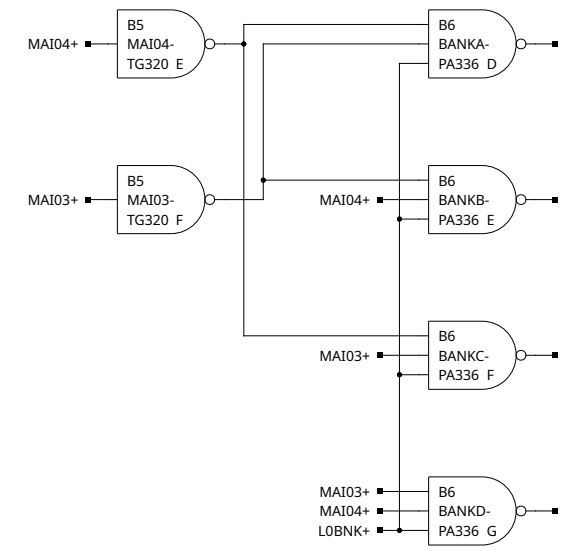
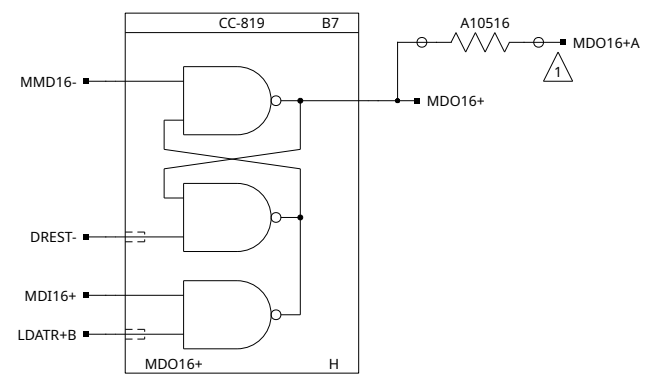
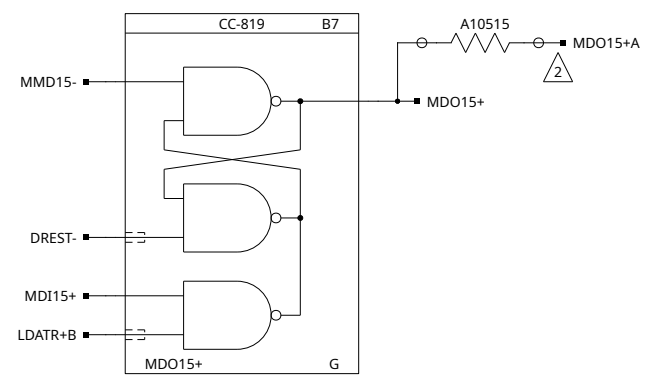

NOTES-

- △ ADD A RESISTOR FROM B10720 TO A10516 ON THE BACKPLANE
- △ ADD A RESISTOR FROM B10729 TO A10515 ON THE BACKPLANE
- △
- △

CHK.	REVISIONS	REV.
#	—	#
		A
S. R. 54-3915		
	ECO 8458	B
	EXT. CHGS SEE ECO 3/27/70	A.K.
	ECO 9490	C
	EXT. CHGS SEE ECO 6/4/71	A.K.
	ECO 9617	D
	SEE ECO 7/2/71	SSR
	ECO 20687	E
	SEE ECO 12/13/72	T.L.B.

**HONEYWELL**  
INC  
COMPUTER CONTROL DIVISION  
Old Connecticut Path, Framingham, Mass

DR. D. HAMEL	DATE
ENG. R. ALBRIGHT	5/13/69
APP.	9/13/69

PROJECT NO. 53217

TITLE	H-316-0602
	MEMORY EXPANSION
	DATA REGISTER BITS 15, 16 & BANK SIGNALS
SIZE	DWG NO.
C	70025827
REV.	E

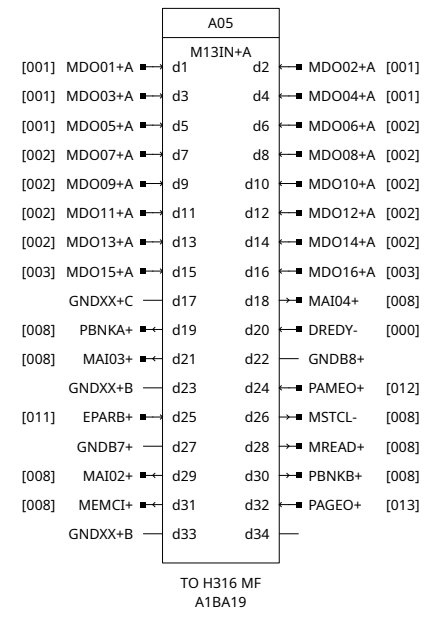
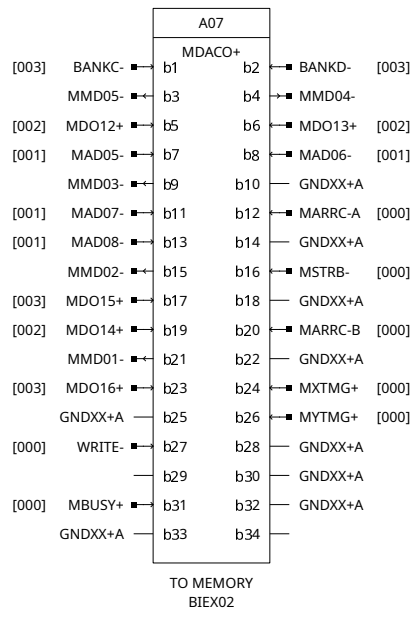
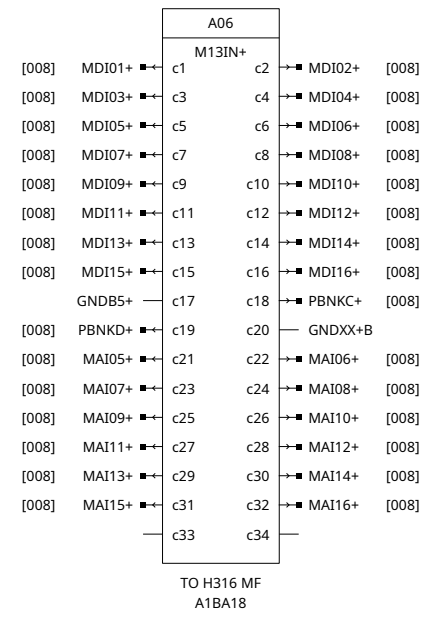
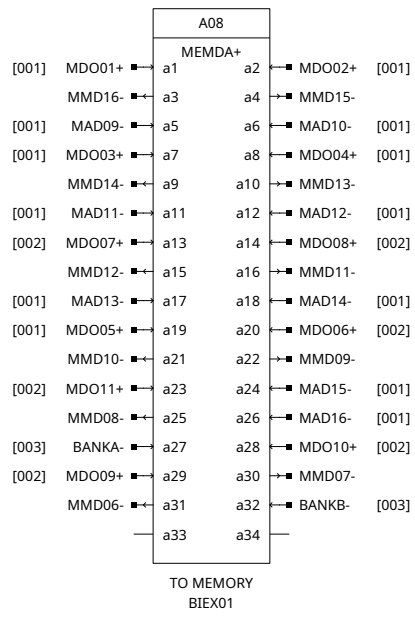

NOTES:  
△  
△  
△  
△

CHK.	REV.	REVISIONS
#	#	—/—

S. R. 54-3915

ECO	REV.
20687	B
12/27	ILLB.

**HONEYWELL**  
INC  
COMPUTER CONTROL DIVISION  
Old Connecticut Path, Framingham, Mass

DR. D. HAMEL	DATE
ENG. R. ALBRIGHT	5/15/69
APP.	9/12/69

PROJECT NO. 53217

TITLE	
H-316	
MEMORY EXPANSION	
C.P. & MEMORY CONN.	
SIZE	DWG NO.
C	70025831
REV.	B

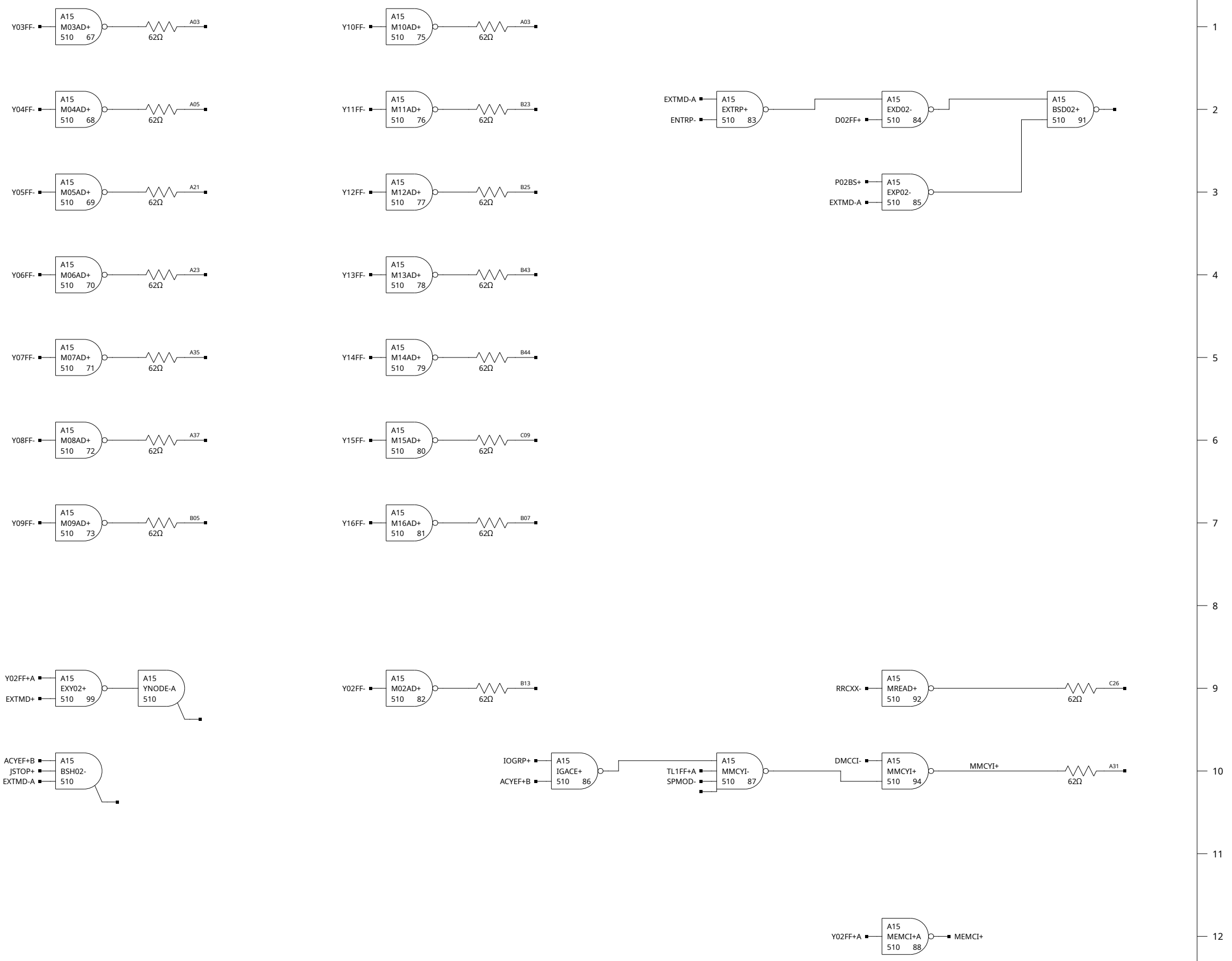

NOTES:  
 △  
 △  
 △  
 △

REV.	REVISIONS
A	
B	

S. R. 54-3915  
 ECO 20687  
 SEE ECO 12/14/72 12/27 1.L.B.

**HONEYWELL**  
 INC  
 COMPUTER CONTROL DIVISION  
 Old Connecticut Path, Framingham, Mass

DR. D. HAMEL	DATE
ENG. R. ALBRIGHT	5-16-69
APP.	9-12-69

PROJECT NO. 53217

TITLE	H-316
	MEMORY EXPANSION/PARITY
	ADDRESS AND CONTROL
SIZE	DWG NO.
C	70025833
REV.	B



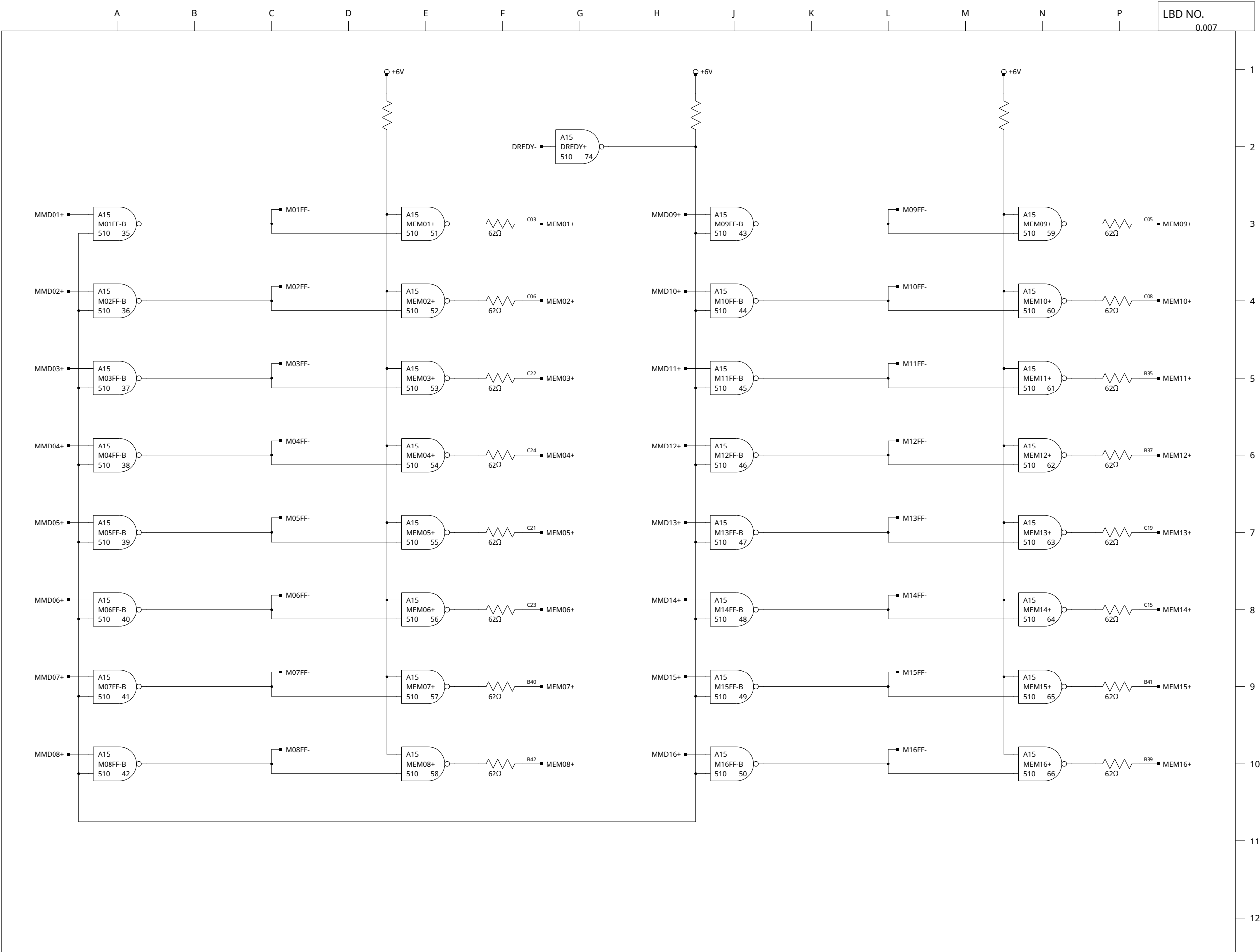

NOTES:  
 △  
 △  
 △  
 △

REV.	REVISIONS
A	
B	
C	
D	
E	
F	
G	
H	
J	
K	
L	
M	
N	
P	

S. R. 54-3915  
 ECO 20687  
 SEE ECO 12/14/72 12/27 T.L.B.

**HONEYWELL**  
 INC  
 COMPUTER CONTROL DIVISION  
 Old Connecticut Path, Framingham, Mass

DR. D. HAMEL	DATE
ENG. R. ALBRIGHT	5-12-69
APP.	9-12-69

PROJECT NO. 53217

TITLE	H-316
	MEMORY EXPANSION/PARITY
SIZE	DWG NO.
C	70025830
REV.	B

1  
2  
3  
4  
5  
6  
7  
8  
9  
10  
11  
12

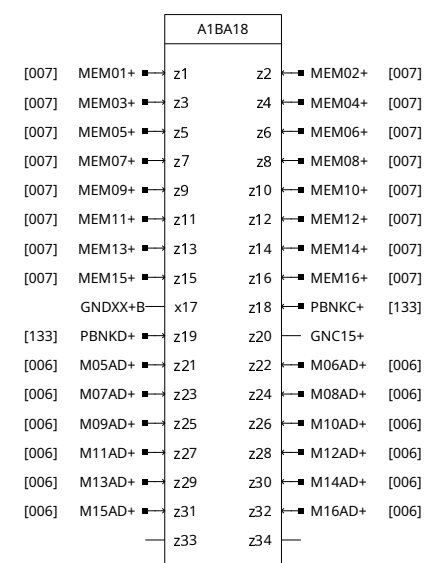

TO MEM. EXPAN 1X3 (A06) WHEN MEM. EXPAN. INSTALLED  
TO PARITY MODULE (A07) WHEN 16K OR LESS PARITY INSTALLED

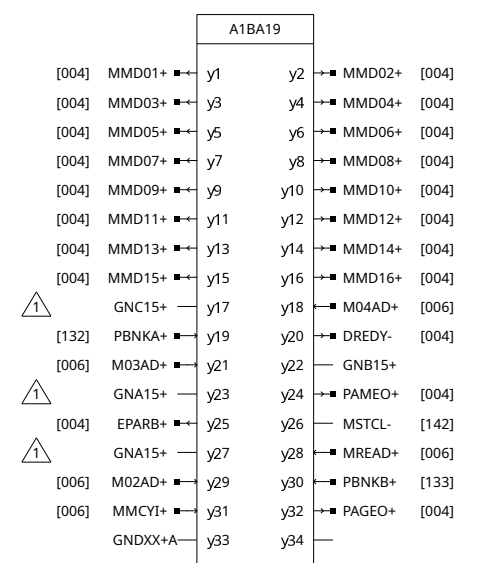

TO MEM. EXPAN 1X3 (A05) WHEN MEM. EXPAN. INSTALLED  
TO PARITY MODULE (A08) WHEN 16K OR LESS PARITY INSTALLED

NOTES-

- △ SEE MAINFRAME COVER SHEET NOTES FOR WIRE CHANGES WHEN 16K OR LESS OF PARITY IS INSTALLED
- △
- △
- △

CHK.	REV.	REVISIONS
#	#	#
		A
		S. R. 54-3915
		ECO 20687
		SEE ECO 12/15/72 12/27 I.L.B.

**HONEYWELL**  
INC  
COMPUTER CONTROL DIVISION  
Old Connecticut Path, Framingham, Mass

DR. D. HAMEL	DATE
ENG. R. ALBRIGHT	5/16/69
APP.	9/12/69

PROJECT NO. 53217

TITLE	H-316
	MEMORY EXPANSION/PARITY
	C. P. CONNECTORS
SIZE	DWG NO.
C	70025832
REV.	B

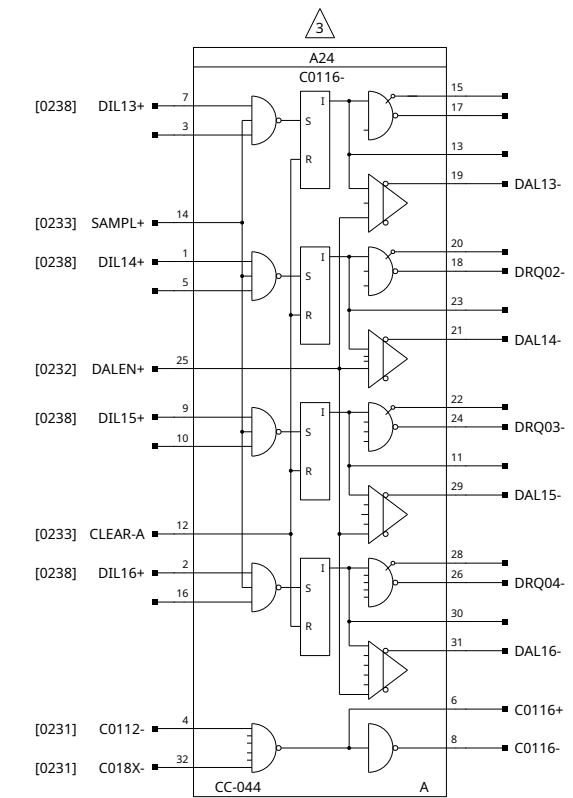
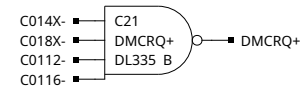
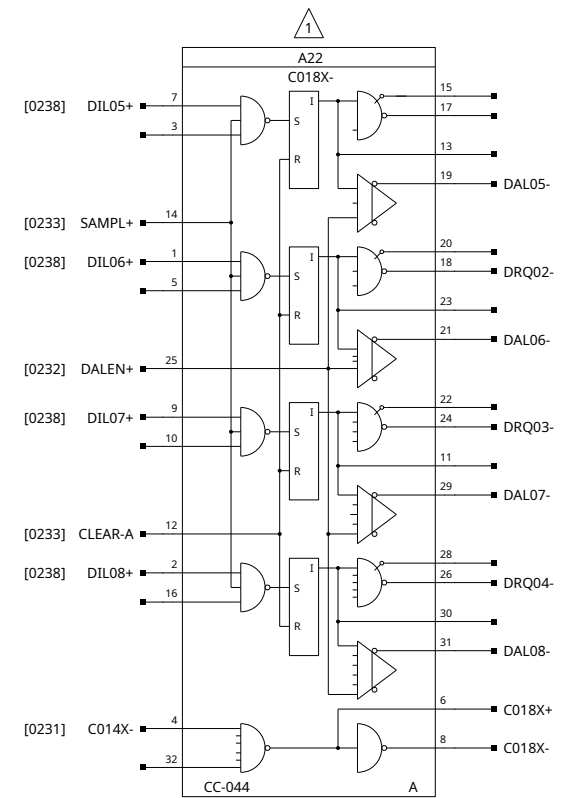
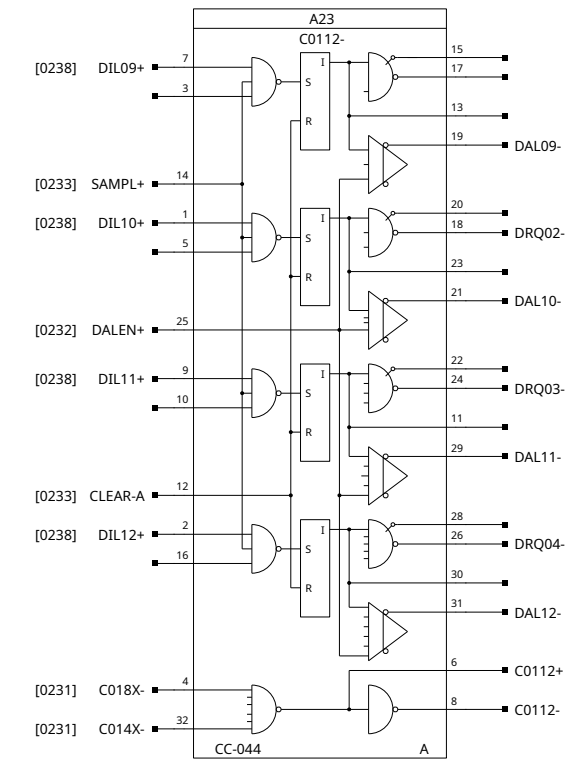
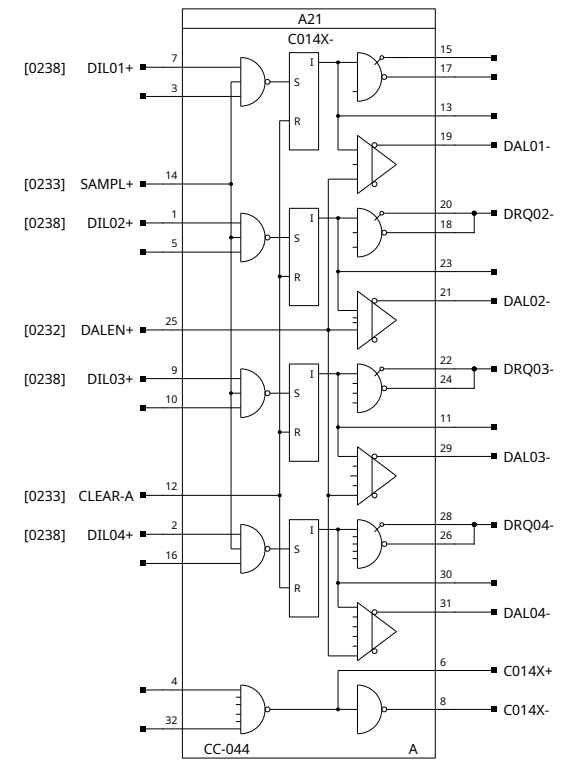

1  
2  
3  
4  
5  
6  
7  
8  
9  
10  
11  
12

- NOTES:
- 1 INSTALL IF MORE THAN 4 CHANNELS
  - 2 INSTALL IF MORE THAN 8 CHANNELS
  - 3 INSTALL IF MORE THAN 12 CHANNELS

CHK.	REV.	A
PER S. R. 54-3788		

**HONEYWELL**  
INC  
COMPUTER CONTROL DIVISION  
Old Connecticut Path, Framingham, Mass

DR. A. KMICINSKI	DATE 6/27/69
ENG. K. ROY	8-22-69
APP. K. ROY	8-22-69
PROJECT NO. 53202	

TITLE	H-316 SDMC
	PRIORITY NET
SIZE	DWG NO. 70025578
REV.	A

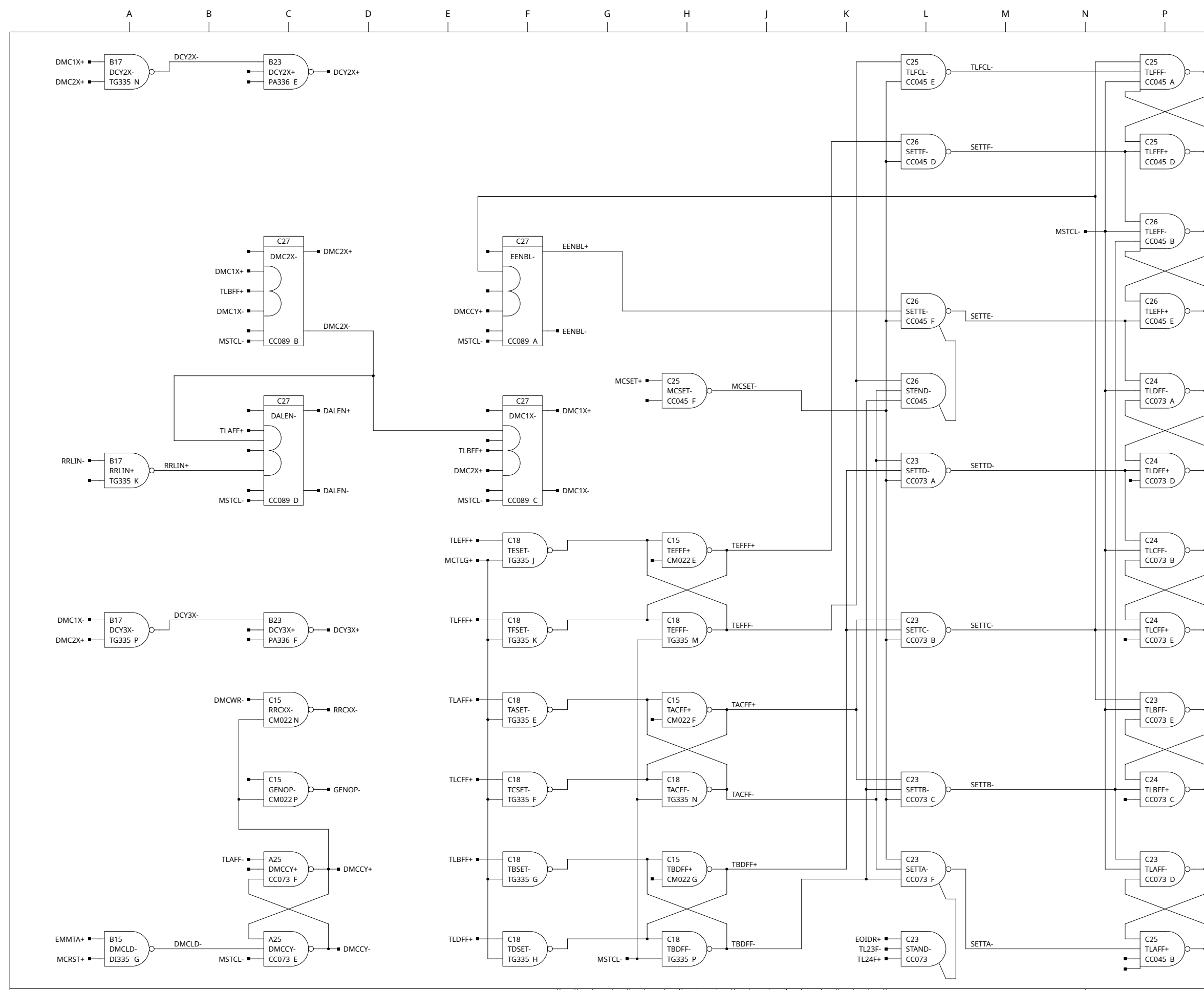

- NOTES:
- △
  - △
  - △
  - △

REV.	A
REVISIONS	
CHK.	

PER S. R. 54-3788

**HONEYWELL** INC.  
 COMPUTER CONTROL DIVISION  
 Old Connecticut Path, Framingham, Mass

DR. A. KMICINSKI DATE 8-22-69  
 ENG. K. ROY 8-22-69  
 APP. 8-22-69

PROJECT NO. 53202

TITLE: H-316 SDMC  
 CYCLE & TLG

SIZE	DWG NO.	REV.
C	70025579	A

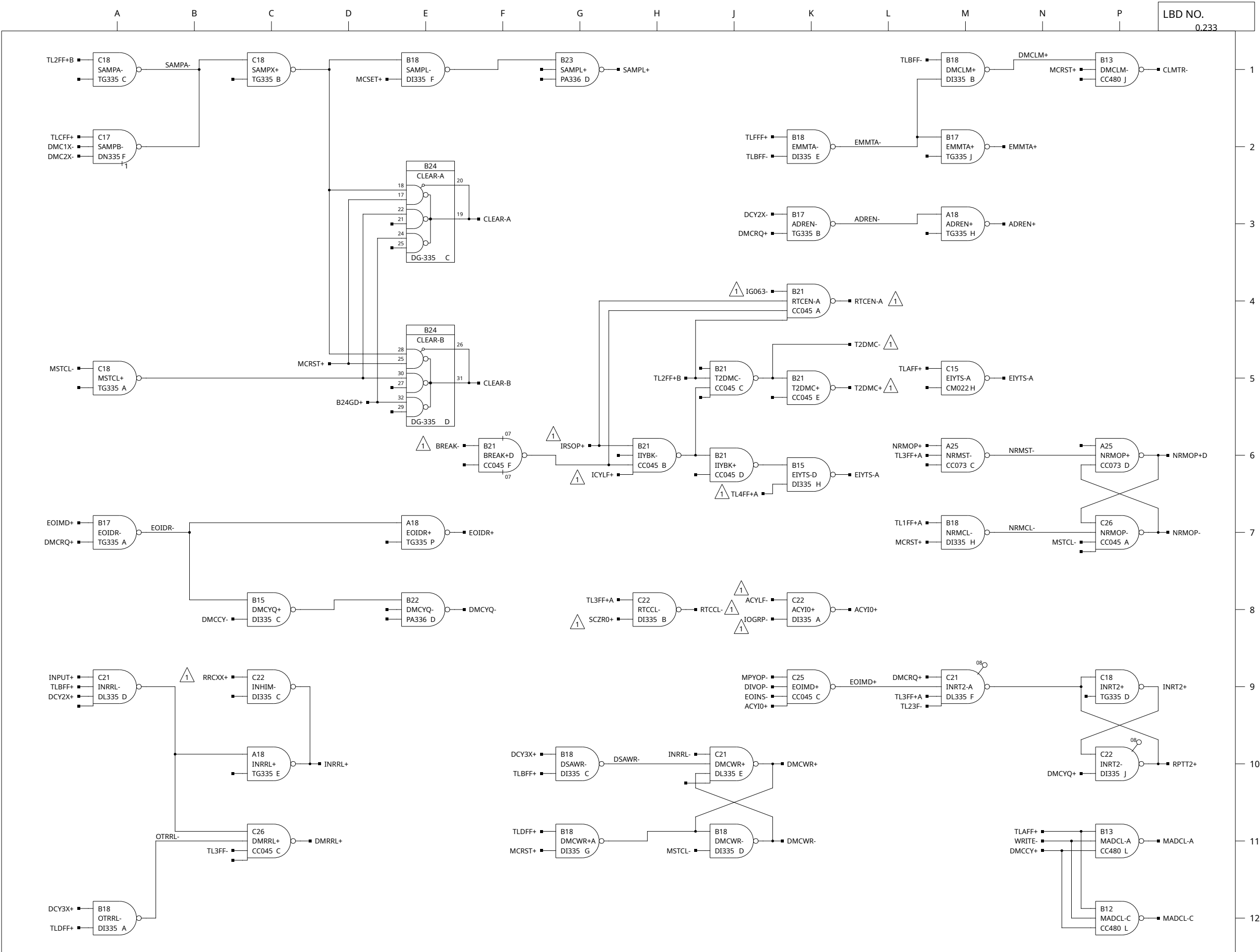

NOTES:  
 1 SEE MAINFRAME COVER SHEET NOTE 9A  
 2  
 3  
 4

CHK.	REVISIONS	REV.
		A
		B
		C
		D
		E
		F
		G
		H
		J
		K
		L
		M
		N
		P

**HONEYWELL**  
 INC  
 COMPUTER CONTROL DIVISION  
 Old Connecticut Path, Framingham, Mass

DR. A. KMICINSKI	DATE 7/11/69
ENG. K. ROY	8-22-69
APP.	8-22-69

PROJECT NO. 53202

TITLE	H-316 SDMC
	CONTROL
SIZE	DWG NO.
C	70025580
REV.	E

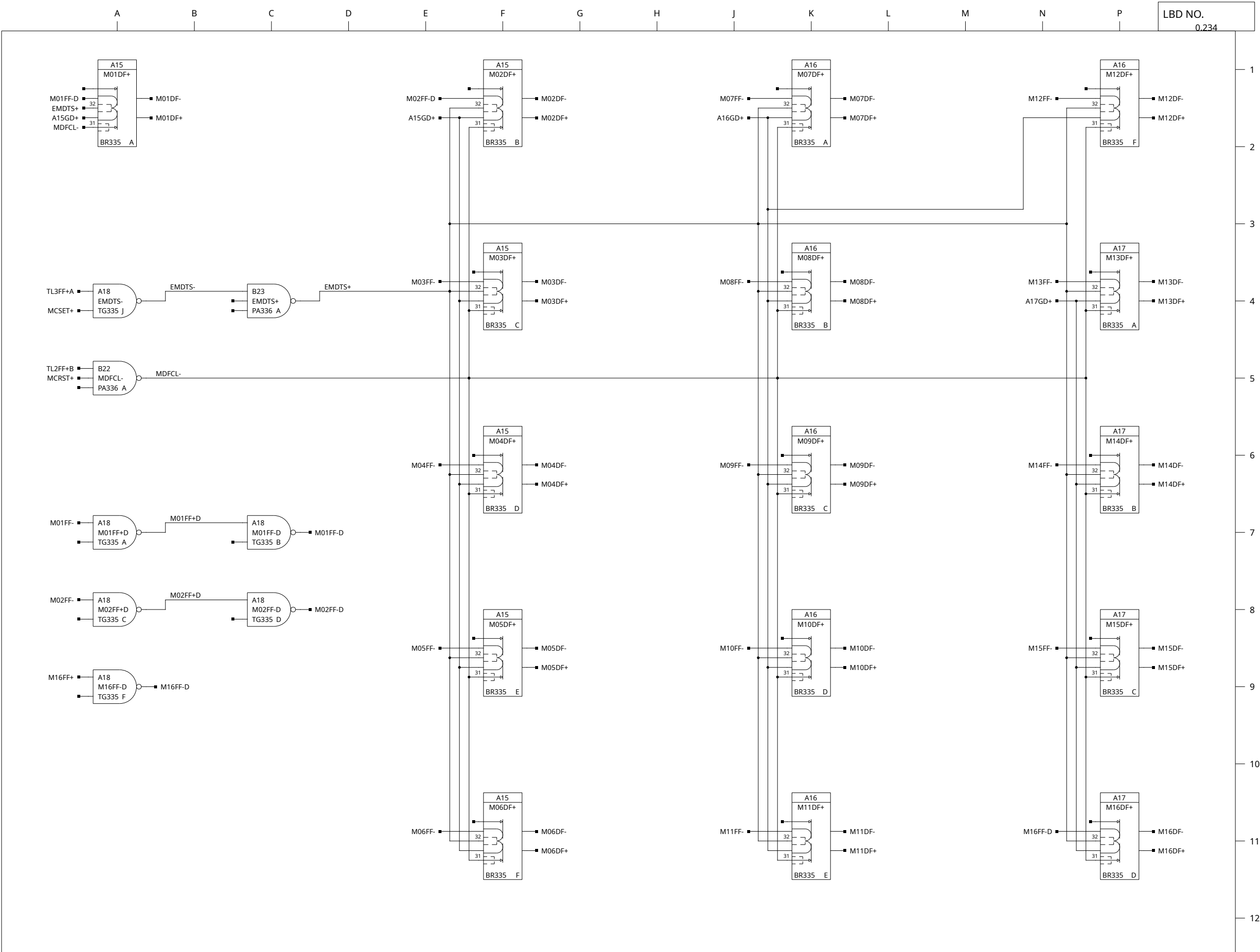

NOTES:  
 △  
 △  
 △  
 △

REV.	REVISIONS
A	

PER S. R. 54-3788

**HONEYWELL**  
 INC  
 COMPUTER CONTROL DIVISION  
 Old Connecticut Path, Framingham, Mass

DR. A. KMICINSKI	DATE 6/30/69
ENG. K. ROY	8-22-69
APP.	8-22-69

PROJECT NO. 53202

TITLE  
 H-316 SDMC  
 M-REG STORAGE

SIZE	DWG NO.	REV.
C	70025581	A

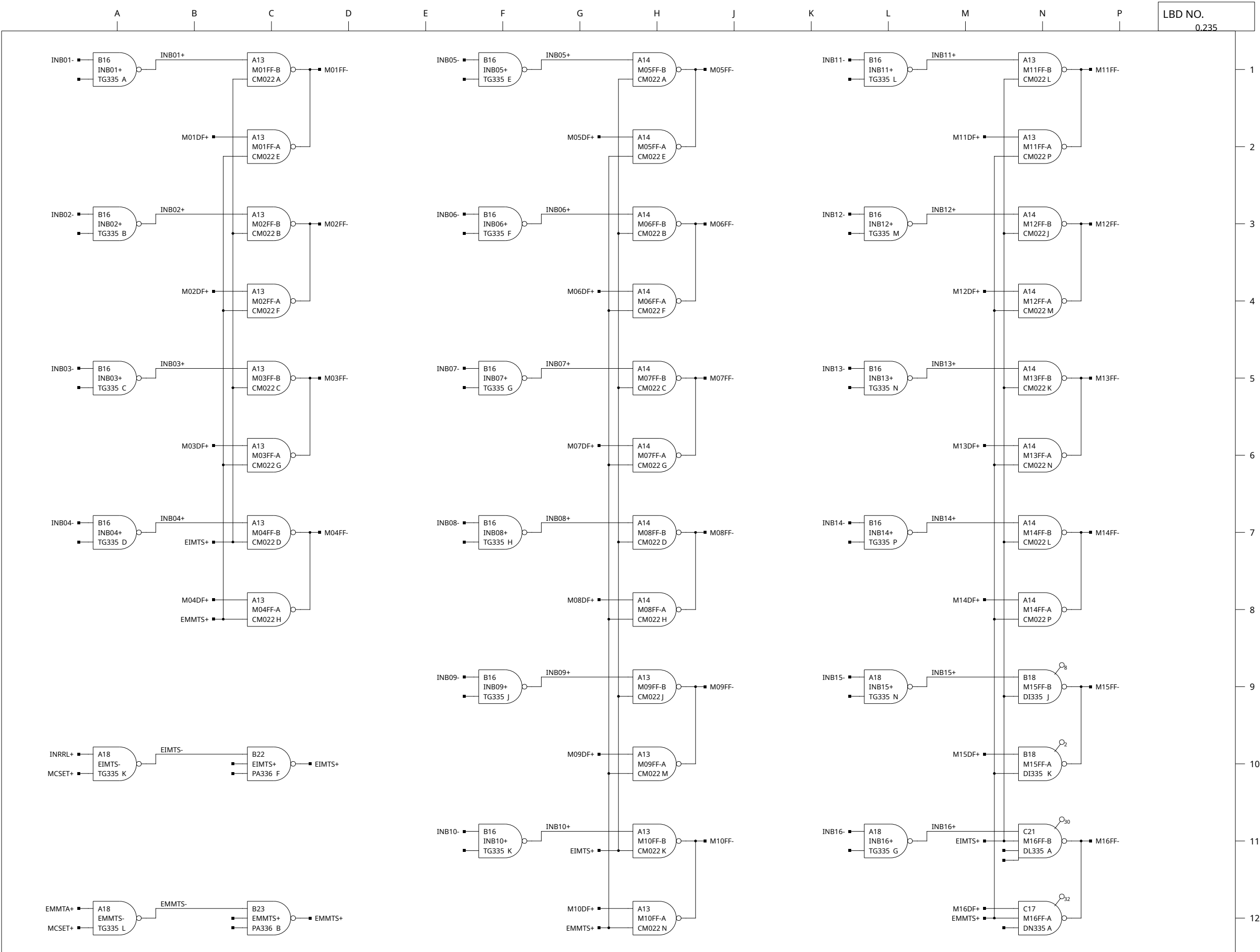

NOTES:  
 △  
 △  
 △  
 △

REV.	REVISIONS
A	
B	ECO 7904 EXT. CHANGES SEE ECO 1/8/70 A.K.
	PER S R 54-3788

**HONEYWELL**  
 INC  
 COMPUTER CONTROL DIVISION  
 Old Connecticut Path, Framingham, Mass

DR. A. KMICINSKI	DATE 7/1/69
ENG. K. ROY	8-22-69
APP.	8-22-69

PROJECT NO. 53202

TITLE	H-316 SDMC
	M-REG INPUT
SIZE	DWG NO. 70025582
REV.	B

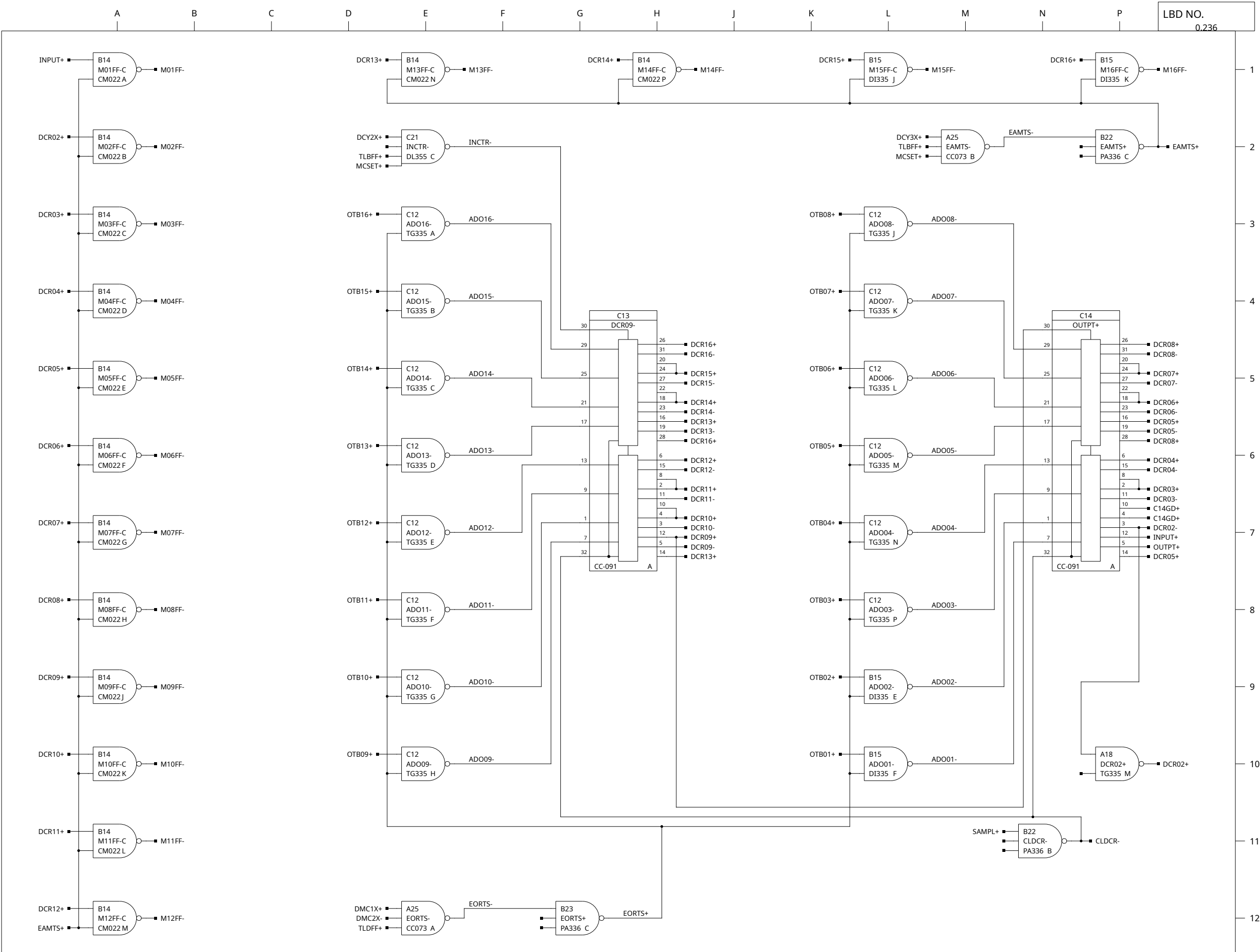

NOTES:  
 △  
 △  
 △  
 △

REV.	REVISIONS	PER. S. R.	ECO #	PER. CH.	DATE
A		PERS. R. 541.3788	#31864	EAC	12/15/73
B					

**HONEYWELL**  
 INC  
 COMPUTER CONTROL DIVISION  
 Old Connecticut Path, Framingham, Mass

DR. A. KMICINSKI	DATE 7/3/69
ENG. K. ROY	8-22-69
APP.	8-22-69

PROJECT NO. 53202

TITLE	H-316 SDMC	ADDRESS REG.
SIZE	DWG NO.	REV.
C	70025583	B



LBD NO.  
0.237

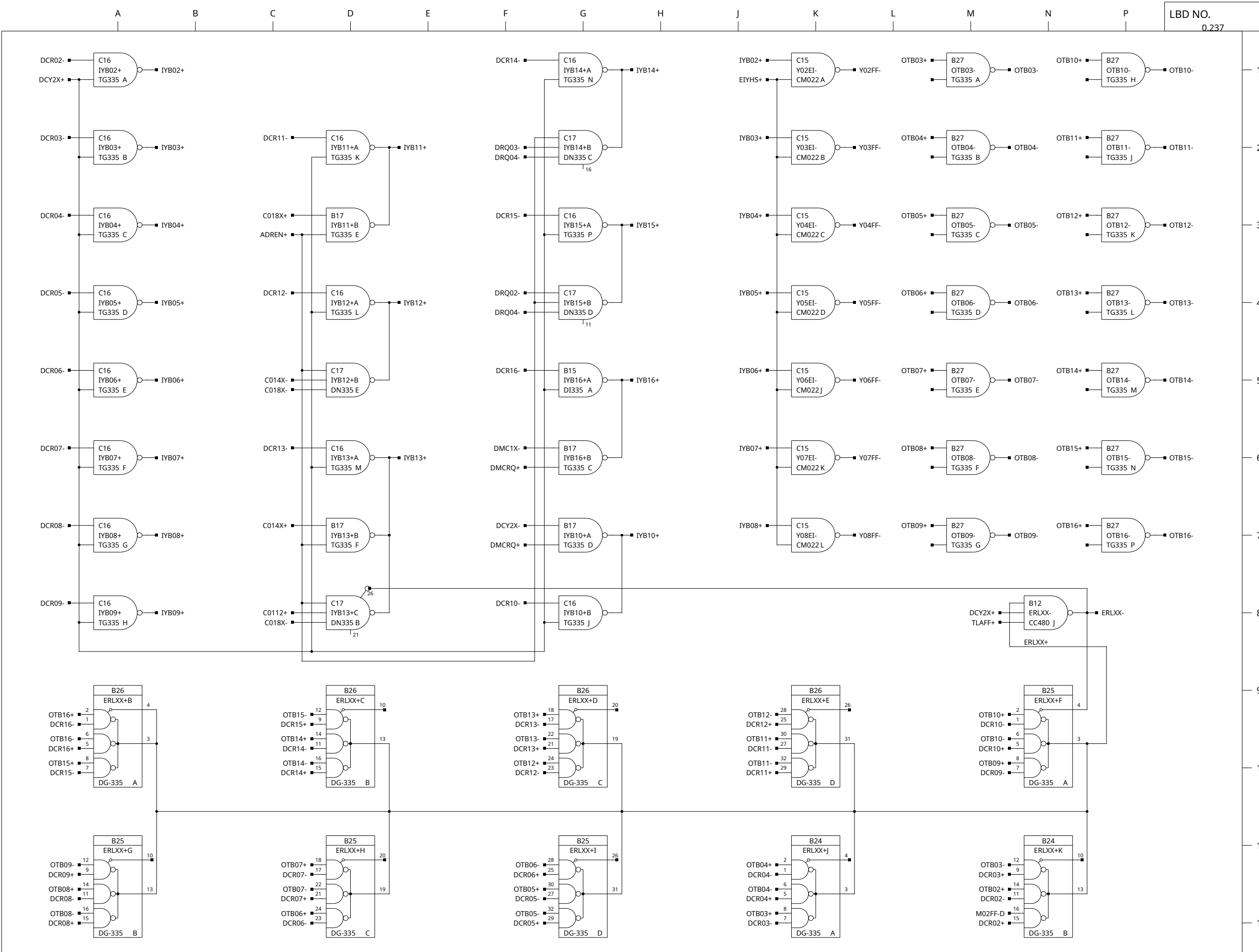

NOTES:  
△  
△  
△  
△

REV.	DESCRIPTION	DATE
A	PER S.R. 541.3788	
B	ECO 10168	
	S.S.R.	
	SEE ECO 2/5/72	

**HONEYWELL**  
INC  
COMPUTER CONTROL DIVISION  
Old Connecticut Path, Framingham, Mass  
DR. A. KMICINSKI DATE 7/7/69  
ENG. K. ROY 8-22-69  
APP. 8-22-69  
PROJECT NO. 53202

TITLE  
H-316 SDMC  
COMPARATOR/IYB  
SIZE DWG NO. REV.  
C 70025584 B

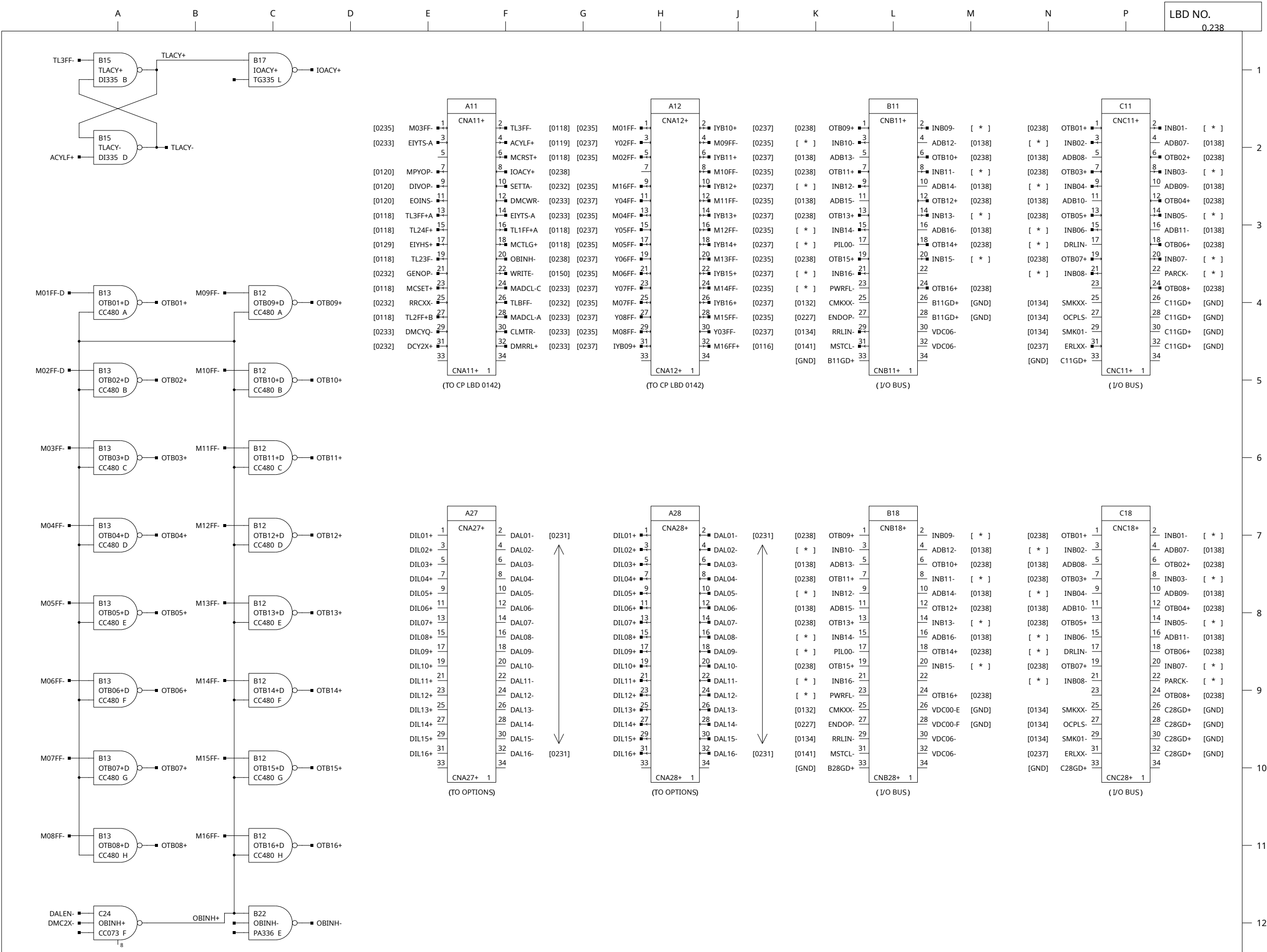

NOTES:  
 △ [ \* ] THESE SIGNALS ARRIVE BY BUS FROM I/O OPTIONS  
 △  
 △  
 △

REV.	REVISIONS	DATE
A	PERS. R. 541.3788	
B	ECO 7904 SEE ECO A. K. 1/8/70	
C	ECO 9425 SEE ECO S.S.R. 5/7/71	
D	ECO 10169 SEE ECO S.S.R. 2/9/72	

**HONEYWELL**  
 INC  
 COMPUTER CONTROL DIVISION  
 Old Connecticut Path, Framingham, Mass

DR. A. KMICINSKI	DATE 7/8/69
ENG. K. ROY	8-22-69
APP.	8-22-69

PROJECT NO. 53202

TITLE	H-316 SDMC
	CABLE & OUT BUS
SIZE	DWG NO. 70025585
REV.	D

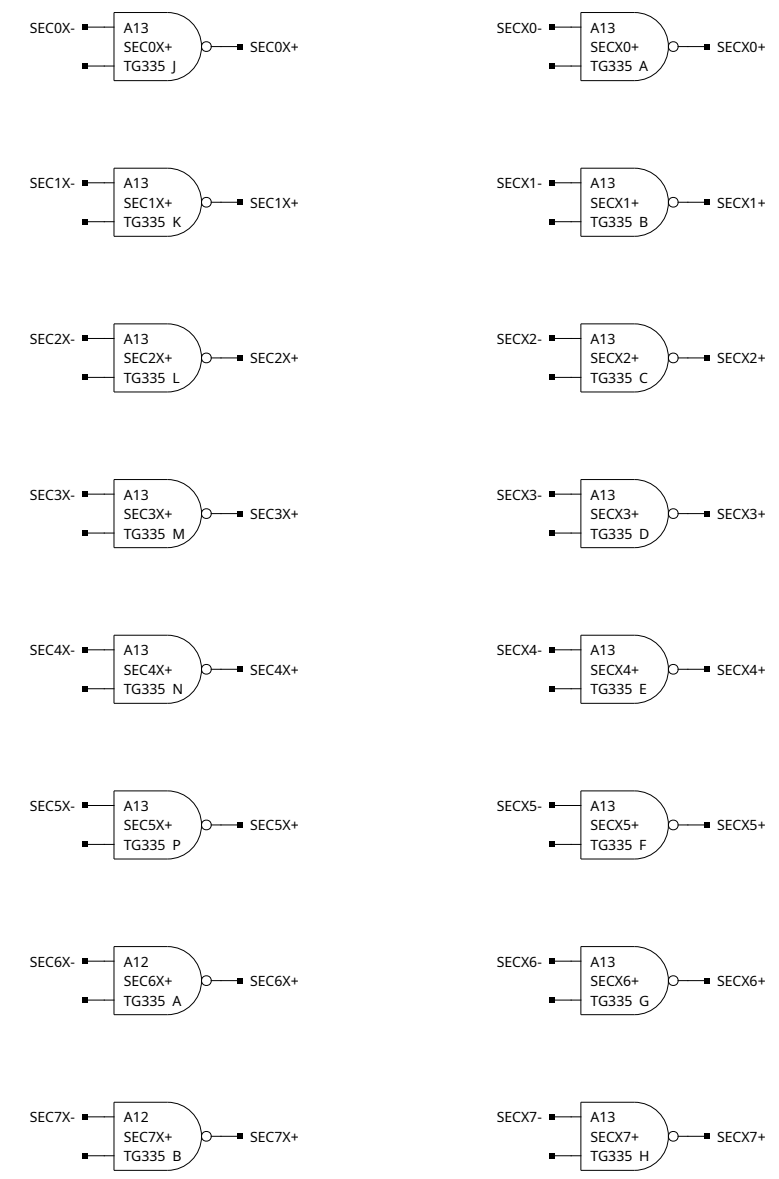
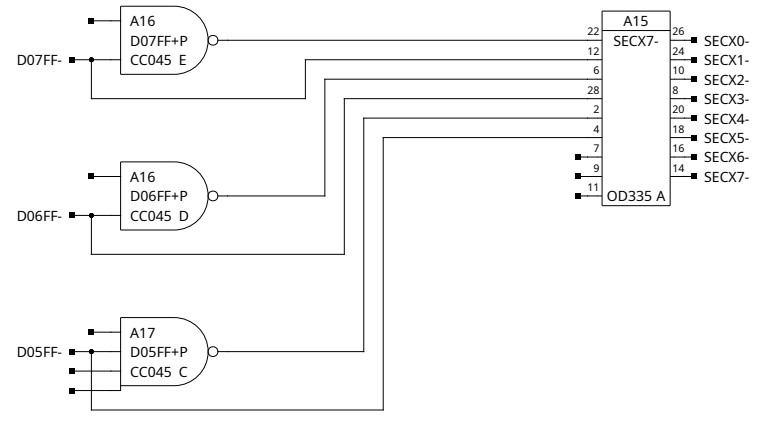
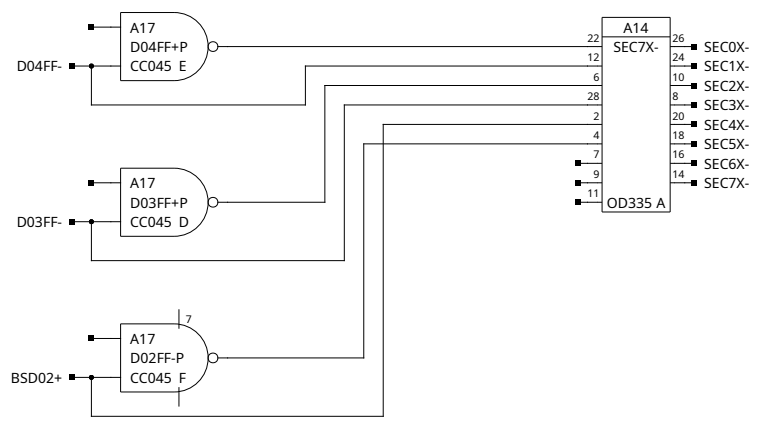

1  
2  
3  
4  
5  
6  
7  
8  
9  
10  
11  
12

NOTES:  
 1 THIS POINT GND WITH NO EXT. ADDRESSING OPTION  
 2  
 3  
 4

CHK.	REV.	REV.	A
#	#	#	#
S. R. 664-4192			

**HONEYWELL**  
 INC  
 COMPUTER CONTROL DIVISION  
 Old Connecticut Path, Framingham, Mass

DR. D. HAMEL	DATE
ENG. K. ROY	11/4/69
APP.	11/5/69

PROJECT NO. 53218

TITLE	H-316-08
	ML SECTOR DECODE
SIZE	C
DWG NO.	70027535
REV.	1

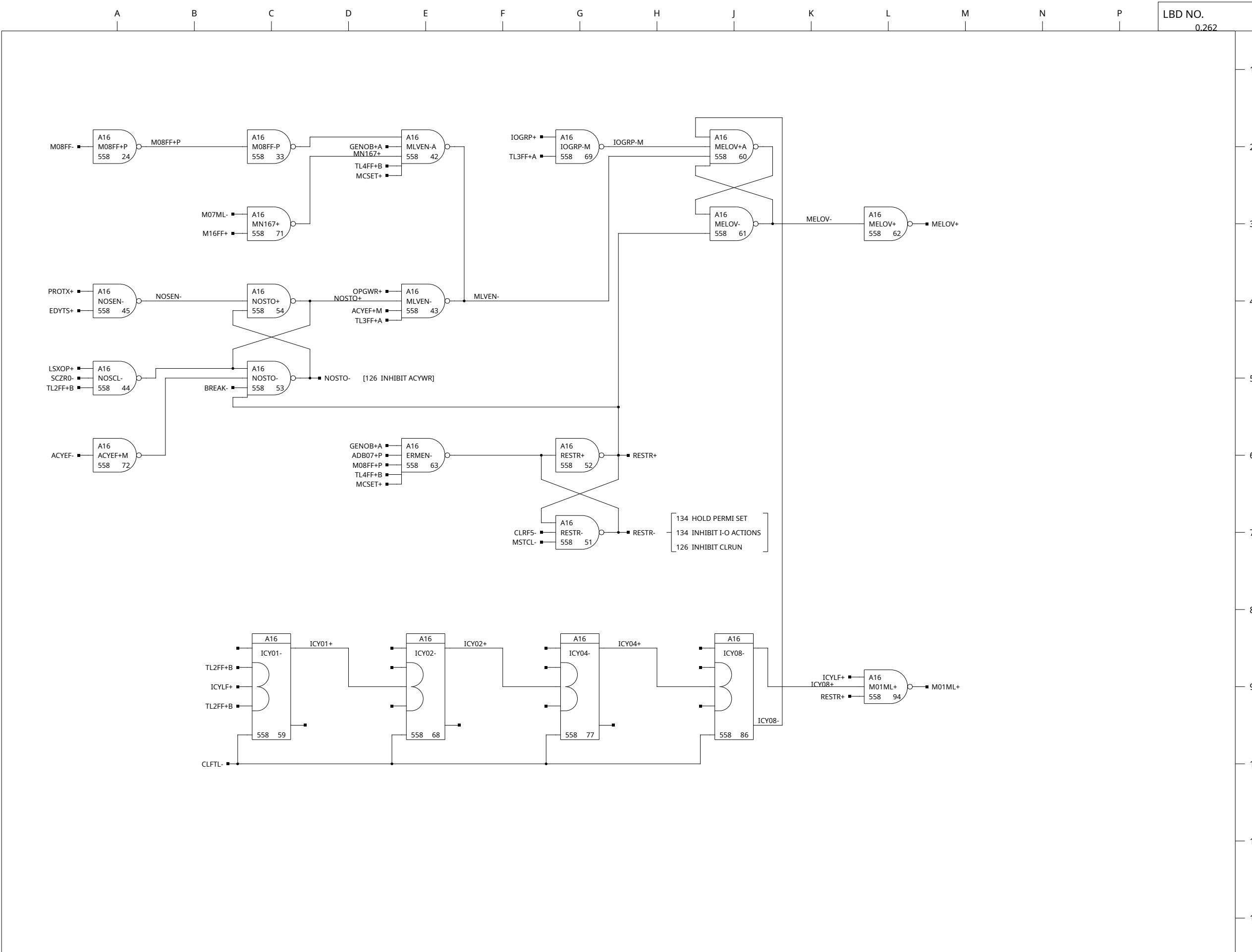

NOTES:  
 △  
 △  
 △  
 △

REV.	REVISIONS	DATE
A		

S. R. 664-4192

**HONEYWELL**  
 INC  
 COMPUTER CONTROL DIVISION  
 Old Connecticut Path, Framingham, Mass

DR. A. KMICINSKI	DATE
ENG. K. ROY	11/4/69
APP.	11/5/69

PROJECT NO. 53218

TITLE	H-316-08
	MLO CONTROL
SIZE	DWG NO.
C	70027536
REV.	/

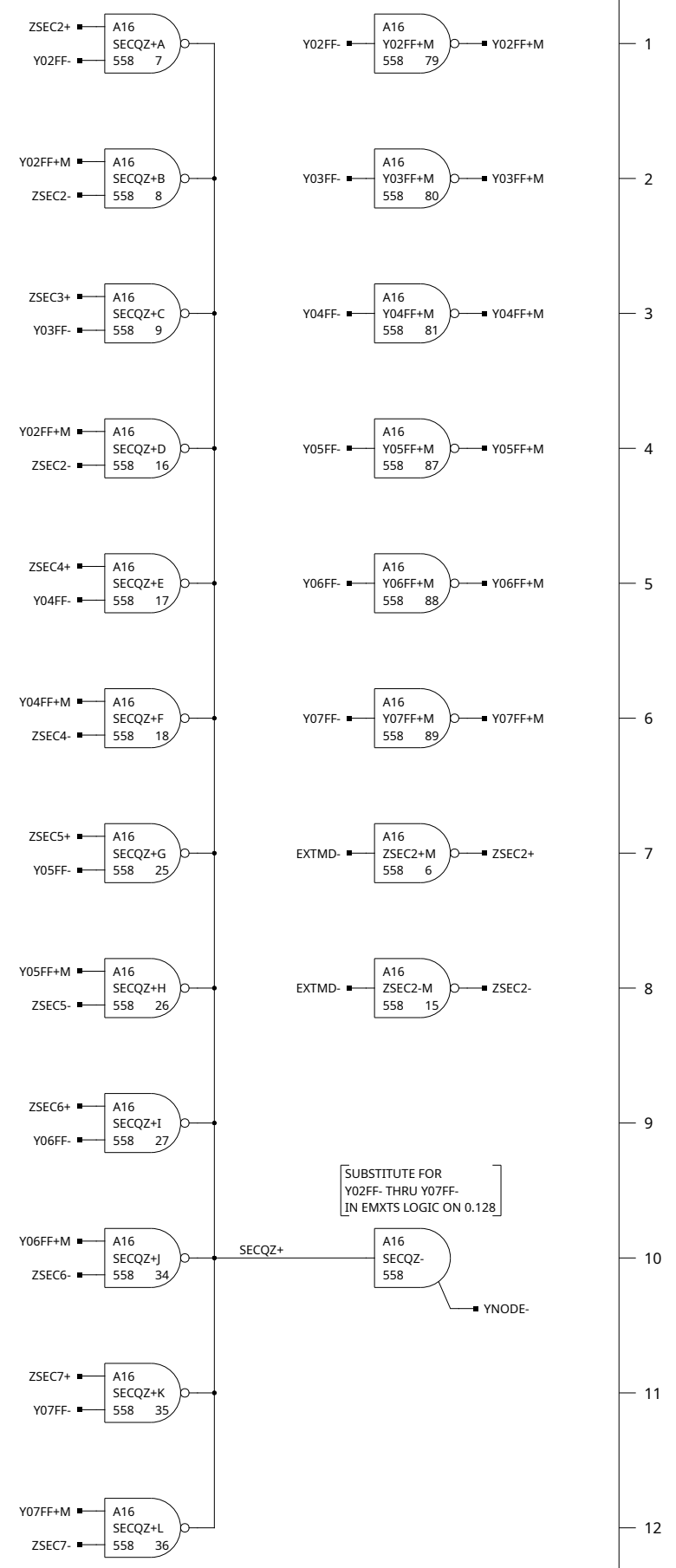
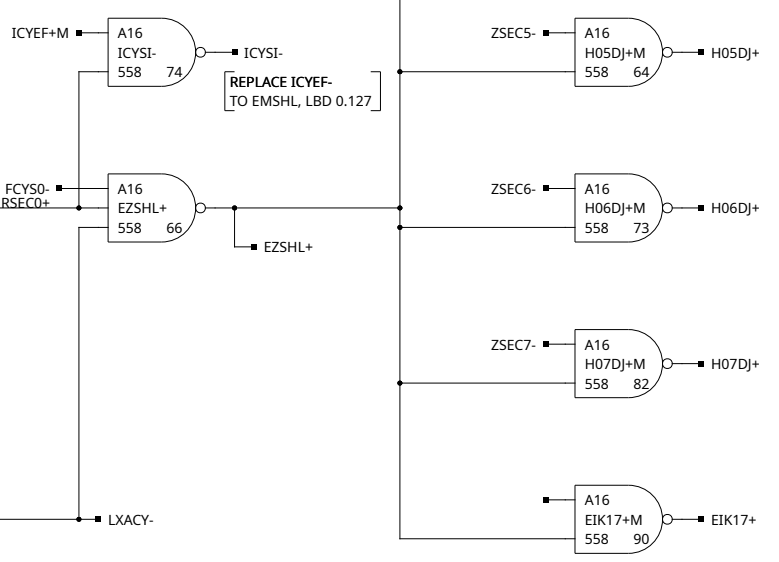
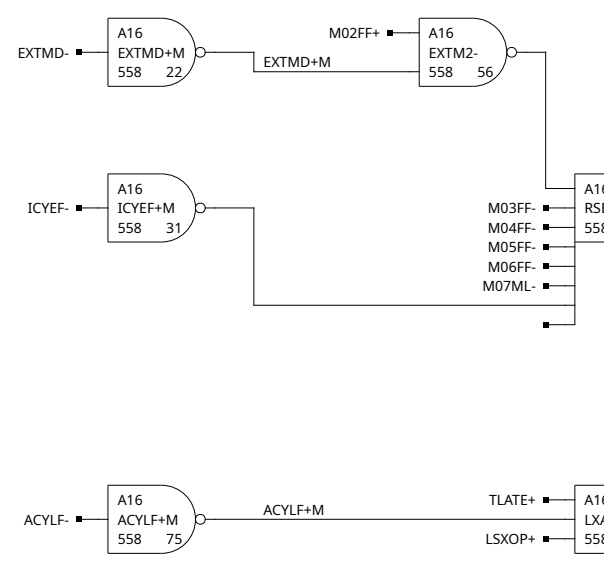
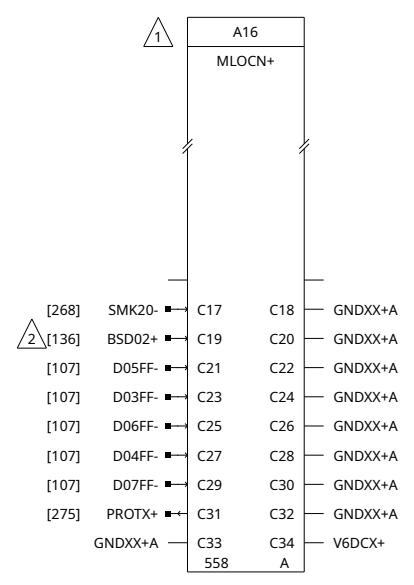

**NOTES:**  
 1 THESE SIGNALS ARE CONNECTED TO SLOT A18 OF THE FIRST MLO 1X3 μ-BLOCK BY MEANS OF A TWISTED PAIR CABLE  
 2 THIS POINT GROUND WITH NO EXTENDED ADDRESSING OPTION  
 3  
 4

REV.	REVISIONS	DATE
A		

S. R. 664-4192

**HONEYWELL**  
 INC  
 COMPUTER CONTROL DIVISION  
 Old Connecticut Path, Framingham, Mass

DR. D. HAMEL	DATE
ENG. K. ROY	11/4/69
APP.	11/5/69

PROJECT NO. 53218

TITLE  
 H-316-08  
 ML BASE SECTOR RELOCATION

SIZE	DWG NO.	REV.
C	70027537	1

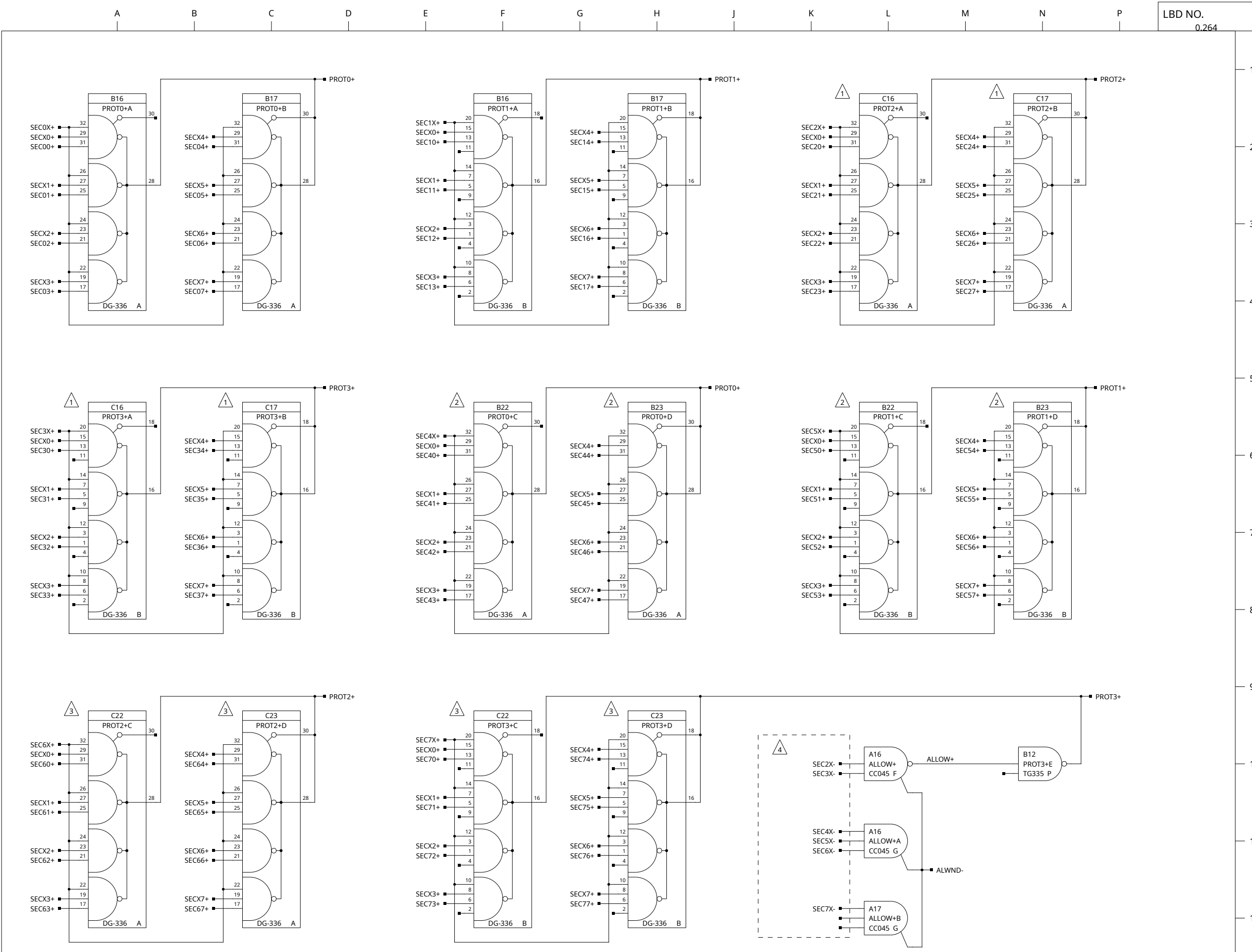

- NOTES:
- 1 THESE PACS INCLUDED IF MORE THAN 8K MLO.
  - 2 THESE PACS INCLUDED IF MORE THAN 16K MLO.
  - 3 THESE PACS INCLUDED IF MORE THAN 24K MLO.
  - 4 SIGNALS WITHIN THIS BLOCK ARE ONLY ADDED WHEN APPLICABLE (SEE WIRE LIST NOTES)

REV.	A
REVISIONS	
CHK.	
S. R. 664-4192	

**HONEYWELL** INC  
COMPUTER CONTROL DIVISION  
Old Connecticut Path, Framingham, Mass

DR. D. HAMEL	DATE
ENG. K. ROY	11/4/69
APP.	11/5/69

PROJECT NO. 53218

TITLE	H-316-08	REV.	/
	ML PROTECT DECODER		
SIZE	DWG NO.		
C	70027538		

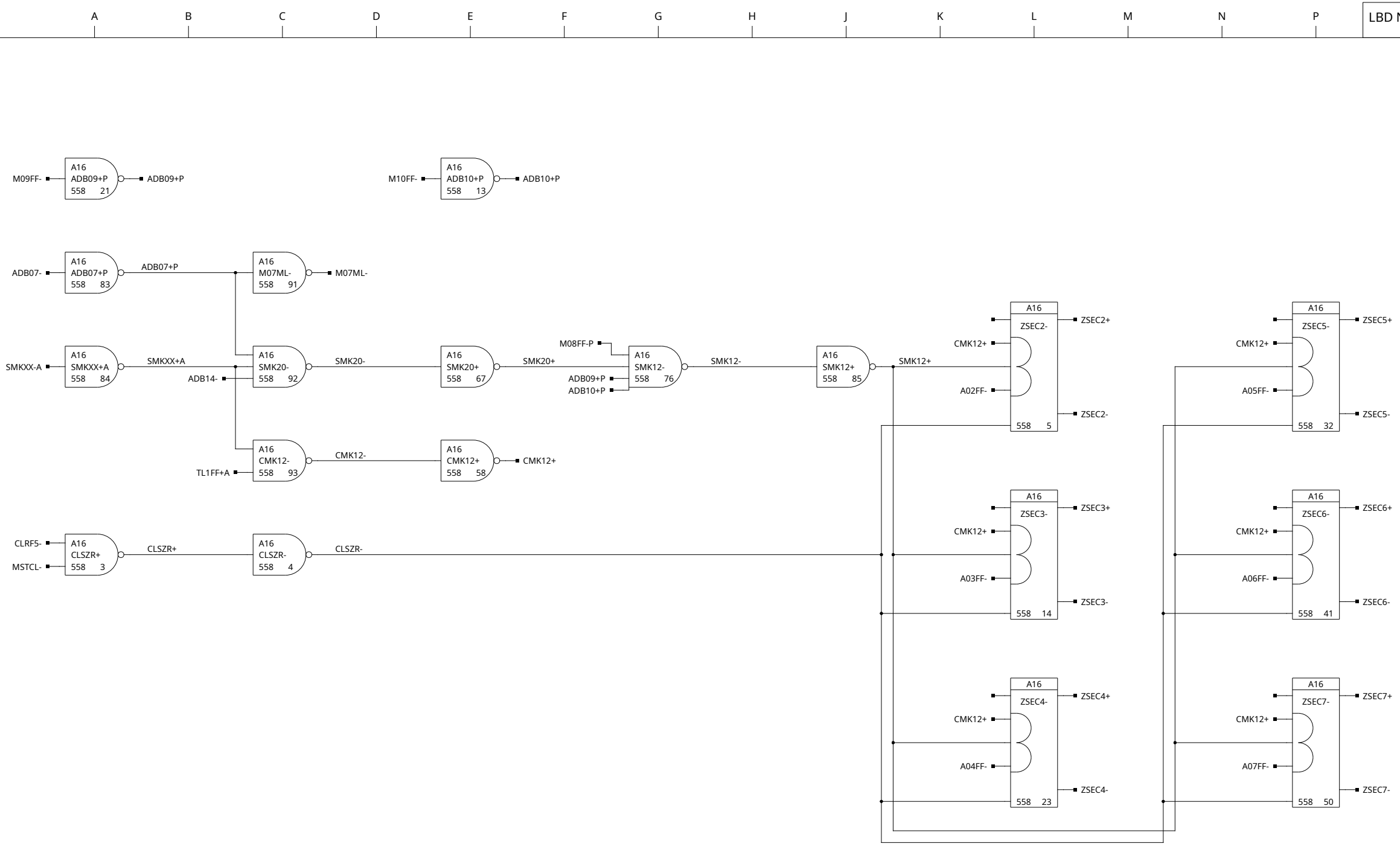

NOTES:  
 △  
 △  
 △  
 △

CHK.	REV.	REVISIONS
#	#	DESCRIPTION
	A	

S. R. 664-4192

**HONEYWELL**  
 INC  
 COMPUTER CONTROL DIVISION  
 Old Connecticut Path, Framingham, Mass

DR. D. HAMEL	DATE
ENG. K. ROY	11/4/69
APP.	11/5/69

PROJECT NO. 53218

TITLE  
 H-316-08  
 Z SEC REGISTER

SIZE	DWG NO.	REV.
C	70027539	1

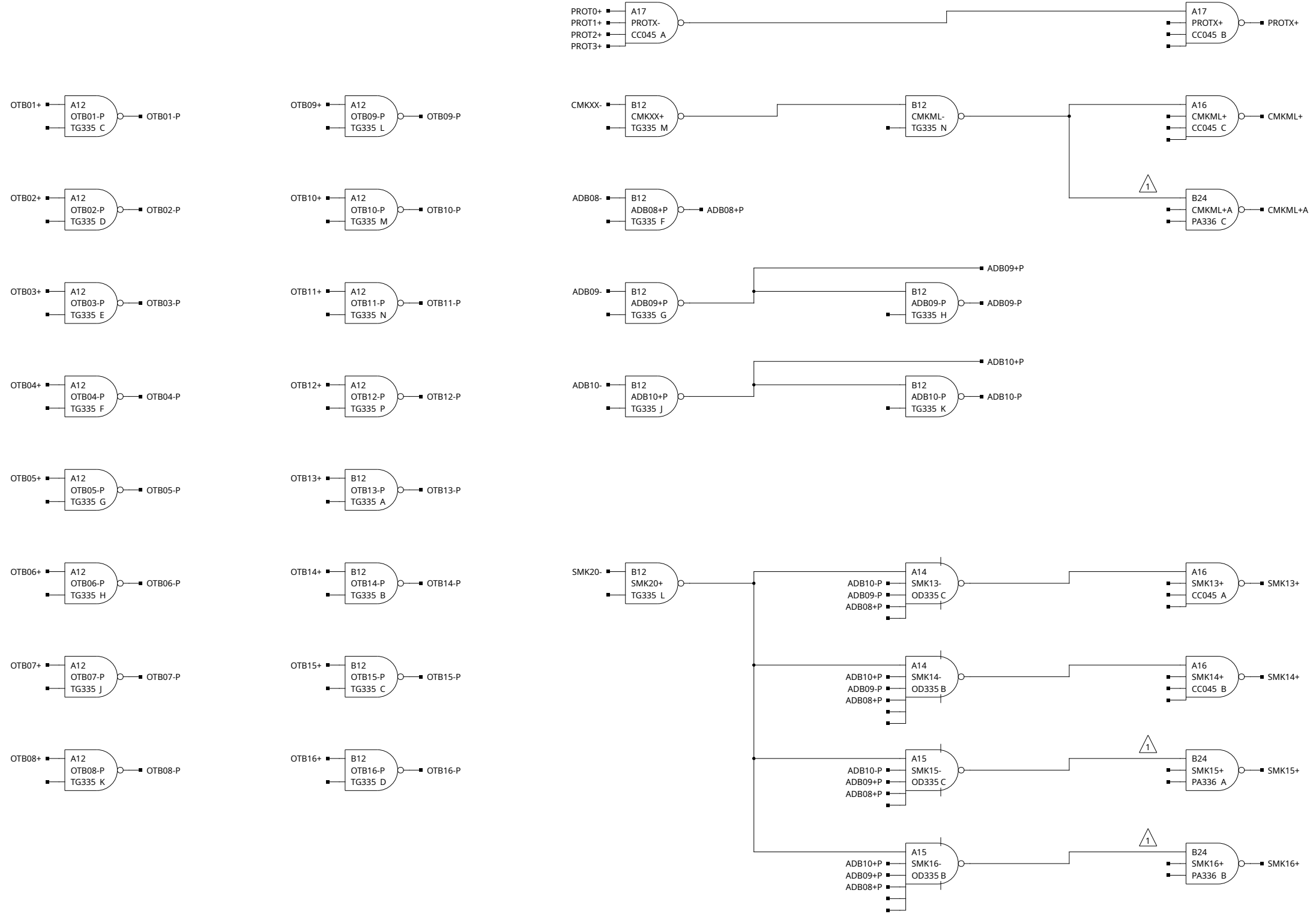

NOTES:  
 ▲ THESE GATE INCLUDED IF MORE THAN 16K MLO  
 ▲  
 ▲  
 ▲

CHK.	REVISIONS	REV.
		A
		B

S. R. 664-4192  
 ECO 9488  
 EXT CHGSPER  
 ECO 9488 5/10/71

**HONEYWELL**  
 INC  
 COMPUTER CONTROL DIVISION  
 Old Connecticut Path, Framingham, Mass

DR. D. HAMEL	DATE
ENG. K. ROY	11/4/69
APP.	11/5/69

PROJECT NO. 53218

TITLE	H-316-08
MLO EXTERNAL	I/O BUS INTERFACE
SIZE	DWG NO.
C	70027540
REV.	B



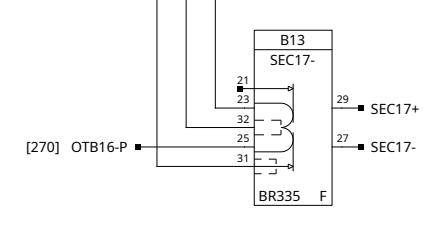
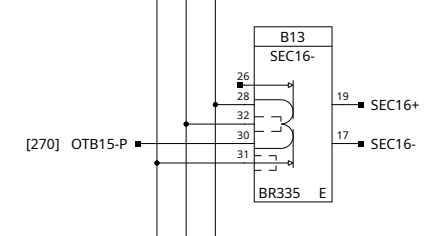
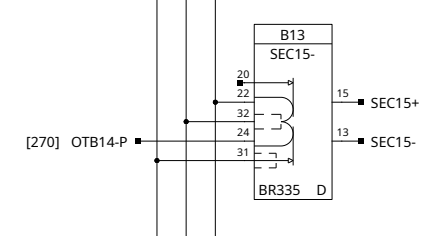
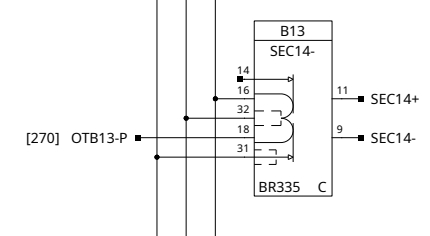
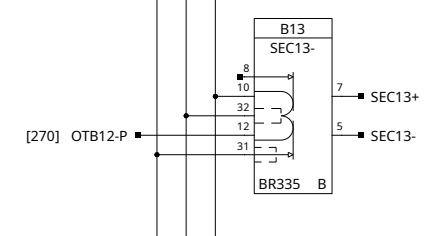
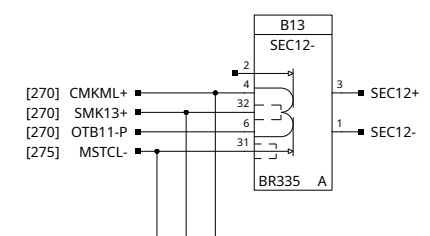
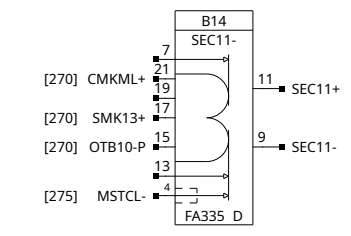
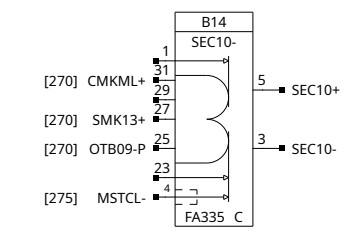
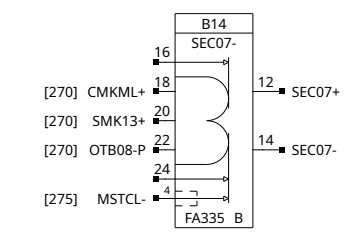
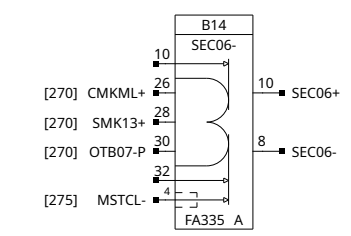
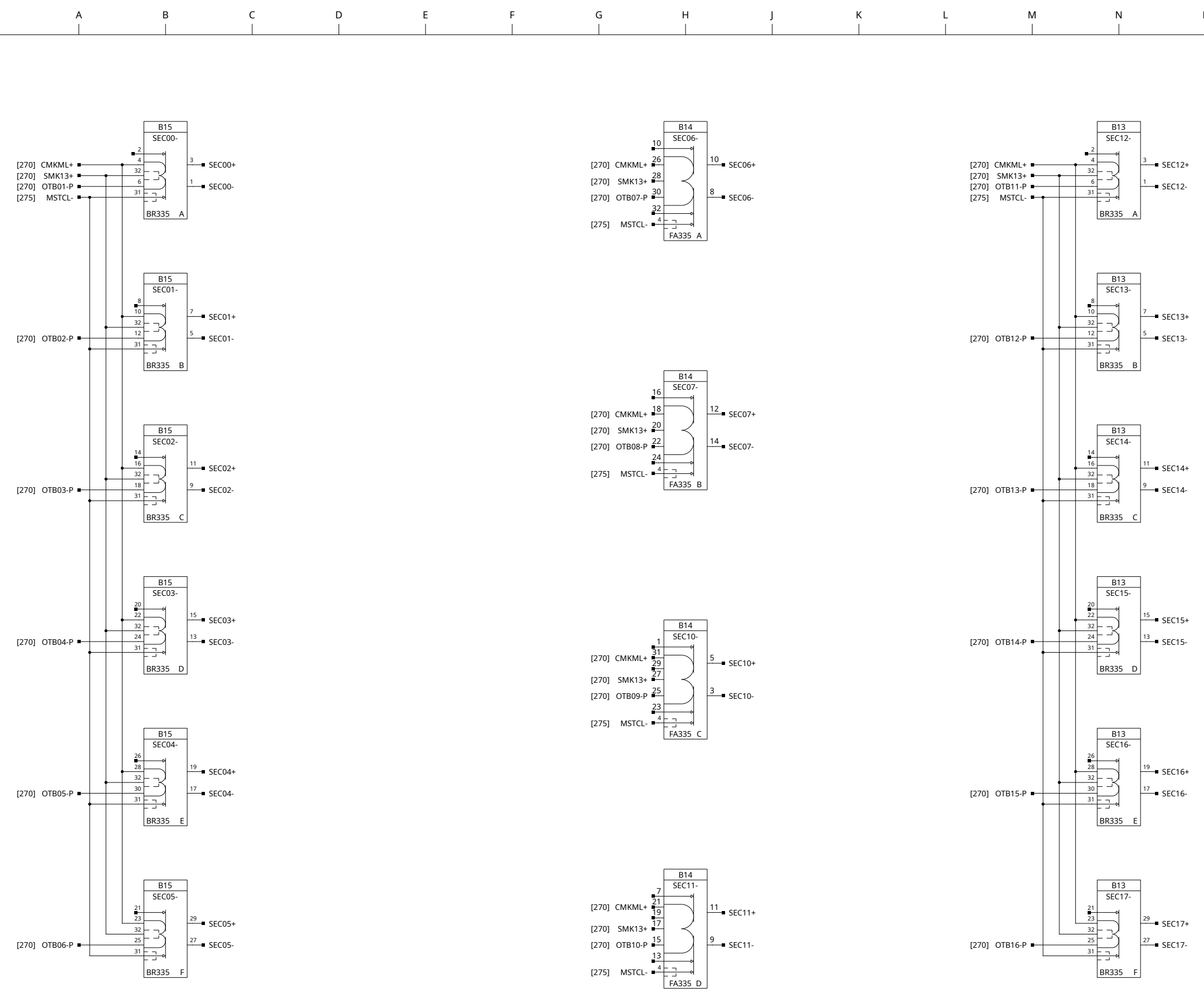

NOTES:  
 △  
 △  
 △  
 △

CHK.	REV.	A
REVISIONS		
S. R. 664-4192		

**HONEYWELL**  
 INC  
 COMPUTER CONTROL DIVISION  
 Old Connecticut Path, Framingham, Mass

DR. D. HAMEL	DATE
ENG. K. ROY	11/4/69
APP.	11/5/69

PROJECT NO. 53218

TITLE  
 H-316-08  
 LOCKOUT MASK REGISTER #1

SIZE	DWG NO.	REV.
C	70027541	/

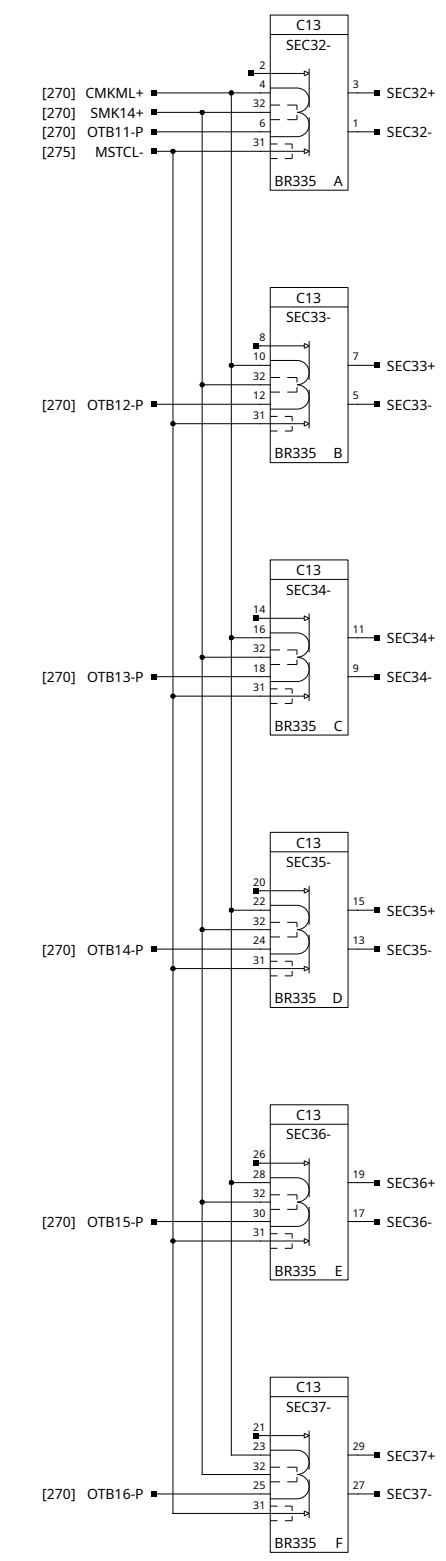
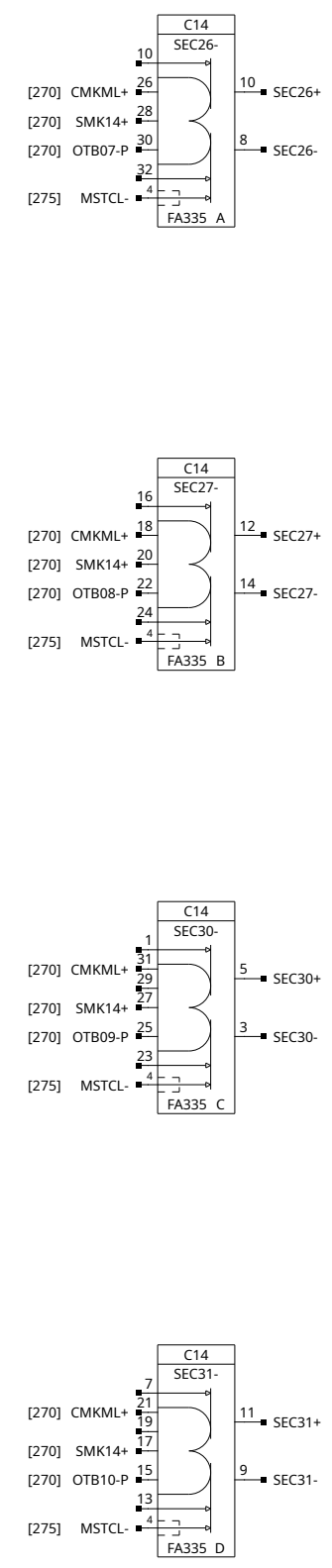
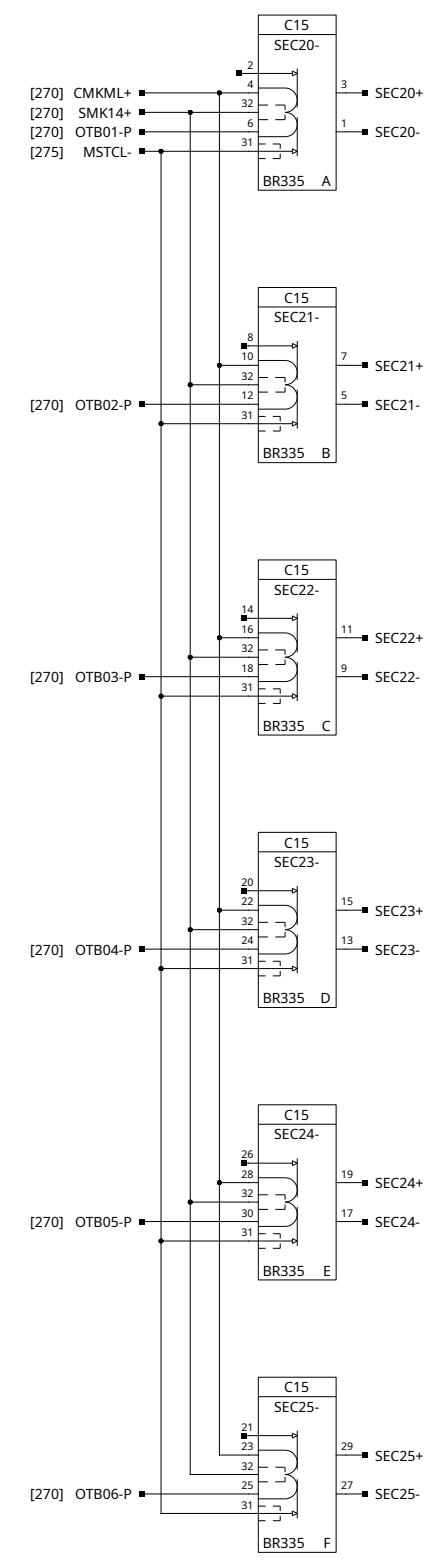

NOTES:  
 ▲ ALL PACS THIS PAGE INCLUDED IF MORE THAN 8K OF MLO.  
 ▲  
 ▲  
 ▲

CHK.	REV.	A																		
	REVISIONS																			
			S. R. 664																	

**HONEYWELL**  
 INC  
 COMPUTER CONTROL DIVISION  
 Old Connecticut Path, Framingham, Mass

DR. D. HAMEL	DATE
ENG. K. ROY	11/4/69
APP.	11/5/69

PROJECT NO. 53218

TITLE  
 H-316-08  
 LOCKOUT MASK REGISTER #2

SIZE	DWG NO.	REV.
C	70027542	1

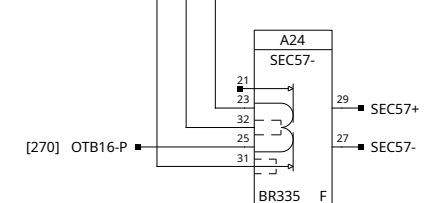
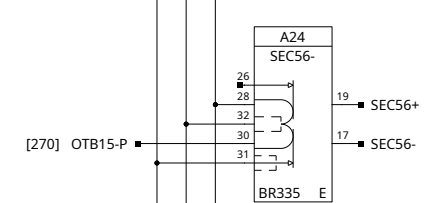
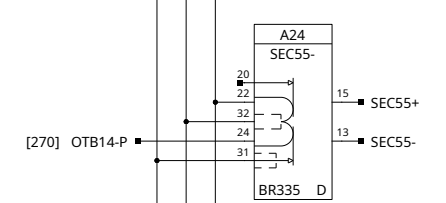
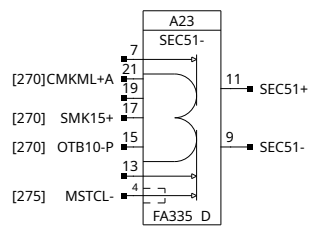
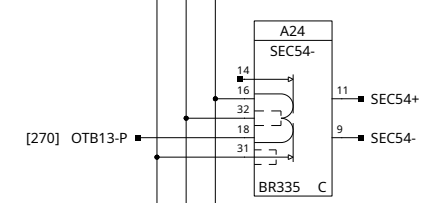
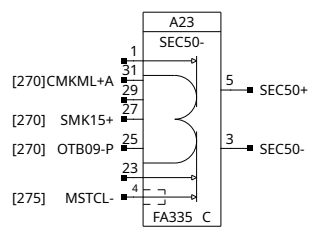
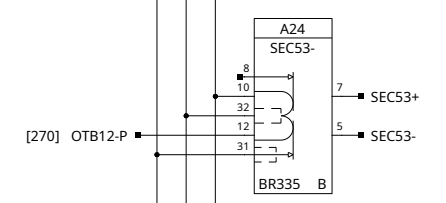
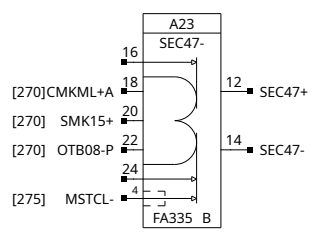
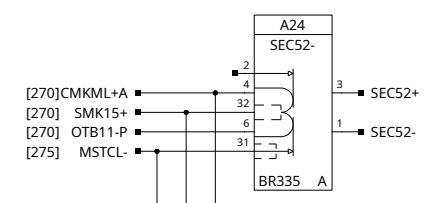
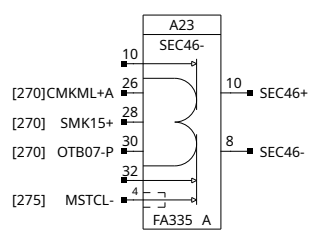
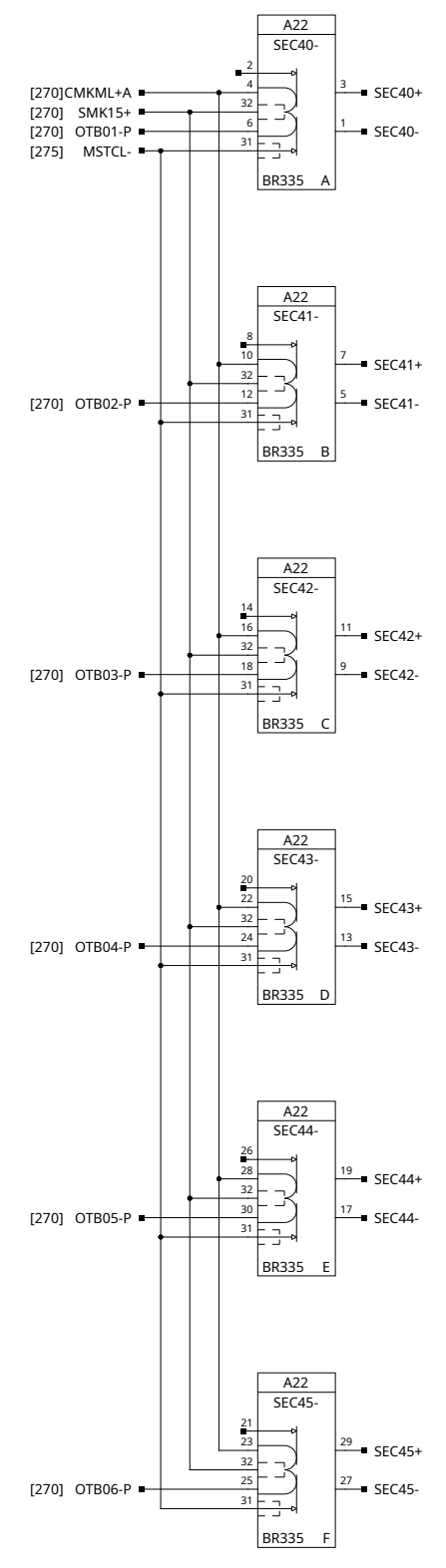

- NOTES:
- △ ALL PACS THIS PAGE INCLUDED IF MORE THAN 16K OF MLO.
  - △
  - △
  - △
  - △

CHK.	REV.	A
#		
S. R. 664-4192		

**HONEYWELL**  
INC  
COMPUTER CONTROL DIVISION  
Old Connecticut Path, Framingham, Mass

DR. D. HAMEL  
ENG. K. ROY  
APP.

DATE  
11/4/69  
11/5/69

TITLE	H-316-08
	LOCKOUT MASK REGISTER #3
SIZE	DWG NO.
C	70027543
REV.	1

PROJECT NO. 53218

A B C D E F G H J K L M N P

LBD NO.  
0.274

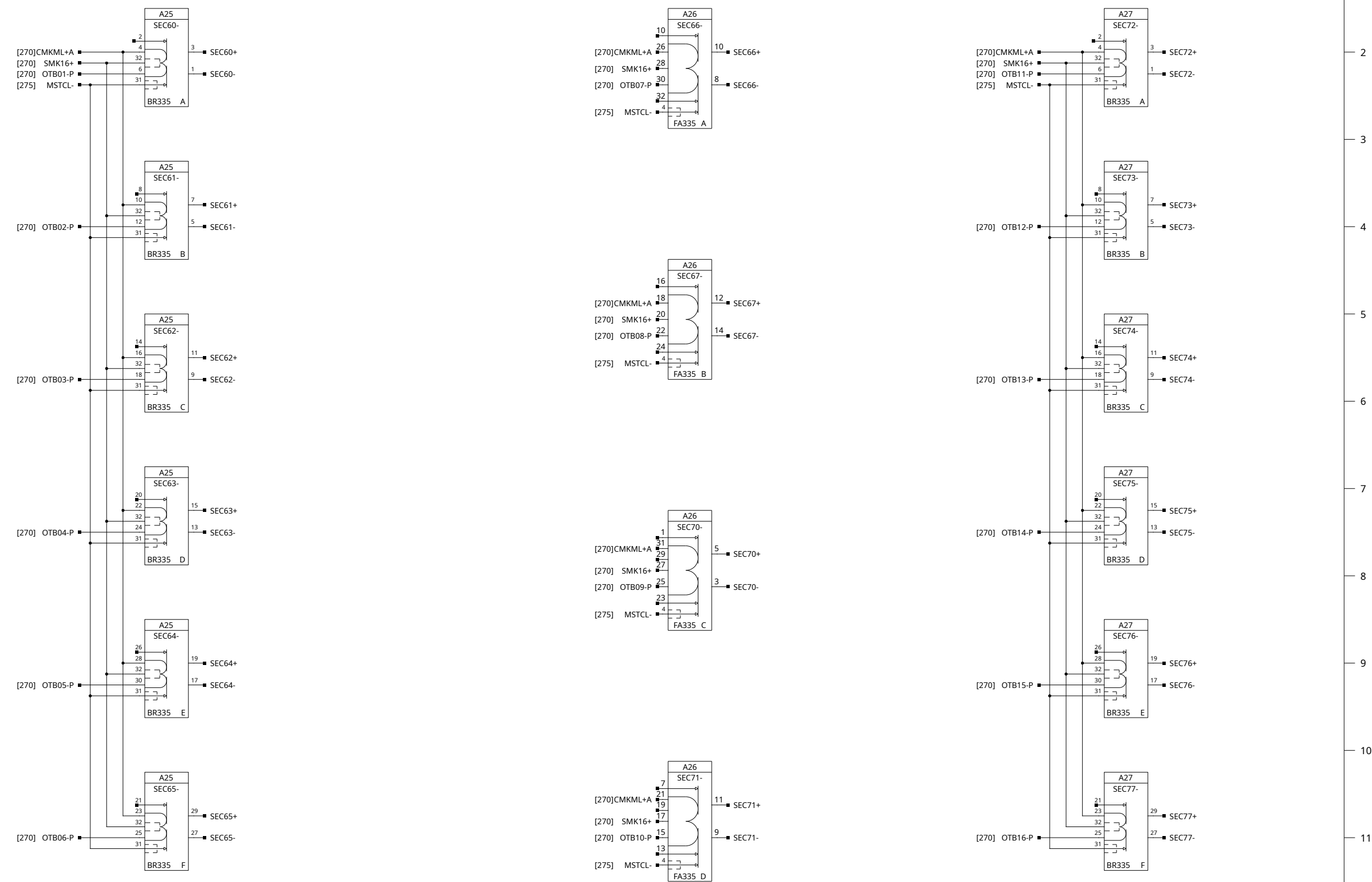

NOTES:  
 ⚠ ALL PACS THIS PAGE INCLUDED IF MORE THAN 24K OF MLO.  
 ▲  
 ▲  
 ▲

CHK.	REVISIONS	REV.	DATE
---	---	A	---

S. R. 664

**HONEYWELL**  
INC  
COMPUTER CONTROL DIVISION  
Old Connecticut Path, Framingham, Mass

DR. D. HAMEL          DATE  
 ENG. K. ROY            11/4/69  
 APP.                      11/5/69

PROJECT NO. 53218	SIZE C	DWG NO. 70027544	REV. 1
-------------------	--------	------------------	--------

TITLE  
H-316-08  
LOCKOUT MASK REGISTER #4

B18		C18	
CNB18+		CNC18+	
[143] OTB09+	1	[143] OTB01+	1
[*] INB10-	3	[*] INB02-	3
[143] ADB13-	5	[143] ADB08-	5
[143] OTB11+	7	[143] OTB03+	7
[*] INB12-	9	[*] INB04-	9
[143] ADB15-	11	[143] ADB10-	11
[143] OTB13+	13	[143] OTB05+	13
[*] INB14-	15	[*] INB06-	15
[*] PIL00-	17	[*] DRLIN-	17
[143] OTB15+	19	[143] OTB07+	19
[*] INB16-	21	[*] INB08-	21
[*] PWRFL-	23	[*] SPARE+A	23
[143] CMKXX-	25	[143] SMKXX-	25
△ ENDOP-	27	[143] OCPLS-	27
[143] RRLIN-	29	[143] SMK01-	29
[143] MSTCL-	31	[143] ERLXX-	31
	33		33
	34		34
CNB18		CNC18	

B28		C28	
CNB28+		CNC28+	
[143] OTB09+Q	1	[143] OTB01+Q	1
[*] INB10-Q	3	[*] INB02-Q	3
[143] ADB13-Q	5	[143] ADB08-Q	5
[143] OTB11+Q	7	[143] OTB03+Q	7
[*] INB12-Q	9	[*] INB04-Q	9
[143] ADB15-Q	11	[143] ADB10-Q	11
[143] OTB13+Q	13	[143] OTB05+Q	13
[*] INB14-Q	15	[*] INB06-Q	15
[*] PIL00-Q	17	[*] DRLIN-Q	17
[143] OTB15+Q	19	[143] OTB07+Q	19
[*] INB16-Q	21	[*] INB08-Q	21
[*] PWRFL-Q	23	[*] SPARE+Q	23
[143] CMKXX-Q	25	[143] SMKXX-Q	25
△ ENDOP-Q	27	[143] OCPLS-Q	27
[143] RRLIN-Q	29	[143] SMK01-Q	29
[143] MSTCL-Q	31	[143] ERLXX-Q	31
	33		33
	34		34
CNB28		CNC28	

SEE NOTE 1

B11		C11	
CNB11+		CNC11+	
[143] OTB09+	1	[143] OTB01+	1
[*] INB10-	3	[*] INB02-	3
[143] ADB13-	5	[143] ADB08-	5
[143] OTB11+	7	[143] OTB03+	7
[*] INB12-	9	[*] INB04-	9
[143] ADB15-	11	[143] ADB10-	11
[143] OTB13+	13	[143] OTB05+	13
[*] INB14-	15	[*] INB06-	15
[*] PIL00-	17	[*] DRLIN-	17
[143] OTB15+	19	[143] OTB07+	19
[*] INB16-	21	[*] INB08-	21
[*] PWRFL-	23	[*] SPARE+A	23
[143] CMKXX-	25	[143] SMKXX-	25
△ ENDOP-	27	[143] OCPLS-	27
[143] RRLIN-	29	[143] SMK01-	29
[143] MSTCL-	31	[143] ERLXX-	31
	33		33
	34		34
CNB11		CNC11	

A18	
CNA18+	
SMK20-	1
BSD02+	3
D05FF-	5
D03FF-	7
D06FF-	9
D04FF-	11
D07FF-	13
PROTX+	15
	17
	19
	21
	23
	25
	27
	29
	31
	33
CNA18	

B21		C21	
CNB21+		CNC21+	
[143] OTB09+Q	1	[143] OTB01+Q	1
[*] INB10-Q	3	[*] INB02-Q	3
[143] ADB13-Q	5	[143] ADB08-Q	5
[143] OTB11+Q	7	[143] OTB03+Q	7
[*] INB12-Q	9	[*] INB04-Q	9
[143] ADB15-Q	11	[143] ADB10-Q	11
[143] OTB13+Q	13	[143] OTB05+Q	13
[*] INB14-Q	15	[*] INB06-Q	15
[*] PIL00-Q	17	[*] DRLIN-Q	17
[143] OTB15+Q	19	[143] OTB07+Q	19
[*] INB16-Q	21	[*] INB08-Q	21
[*] PWRFL-Q	23	[*] SPARE+Q	23
[143] CMKXX-Q	25	[143] SMKXX-Q	25
△ ENDOP-Q	27	[143] OCPLS-Q	27
[143] RRLIN-Q	29	[143] SMK01-Q	29
[143] MSTCL-Q	31	[143] ERLXX-Q	31
	33		33
	34		34
CNB21		CNC21	

SEE NOTE 1

- NOTES:
- △ INCLUDED IF MORE THAN 16K MLO.
  - △ [\*] THESE SIGNALS ARRIVE BY BUS FROM I/O OPTIONS, DEPENDING ON SYSTEM CONFIGURATION.
  - △ THESE SIGNALS ARRIVE FROM H-316-21 HSDMC.
  - △ THESE SIGNALS ARE CONNECTED TO SLOT C16 OF THE CPU MAINFRAME BY MEANS OF A TWISTED PAIR CABLE.

CHK.	REV.	DATE
	A	
S. R. 664-4192		

**HONEYWELL**  
INC  
COMPUTER CONTROL DIVISION  
Old Connecticut Path, Framingham, Mass

DR. D. HAMEL	DATE
ENG. K. ROY	11/4/69
APP.	11/5/69

PROJECT NO. 53218

TITLE  
H-316-08  
ML EXTERNAL CABLES

SIZE C DWG NO. 70027545 REV. /