

LBD NO. 0.101

NOTES-

- △
- △
- △
- △

REV.	REVISIONS	DATE
A		
B	ECO 7748	11/19/76
	EXT CHANGES SEE ECO 7748	

HONEYWELL
INC
COMPUTER CONTROL DIVISION
Old Connecticut Path, Framingham, Mass

DR. D. HAMEL	DATE
ENG. K. IZBIKLI	11-26-68
APP.	7-8-69

PROJECT NO. 55202

TITLE	H-316
COLUMN No.	1
SIZE	DWG NO.
C	70024485
REV	B

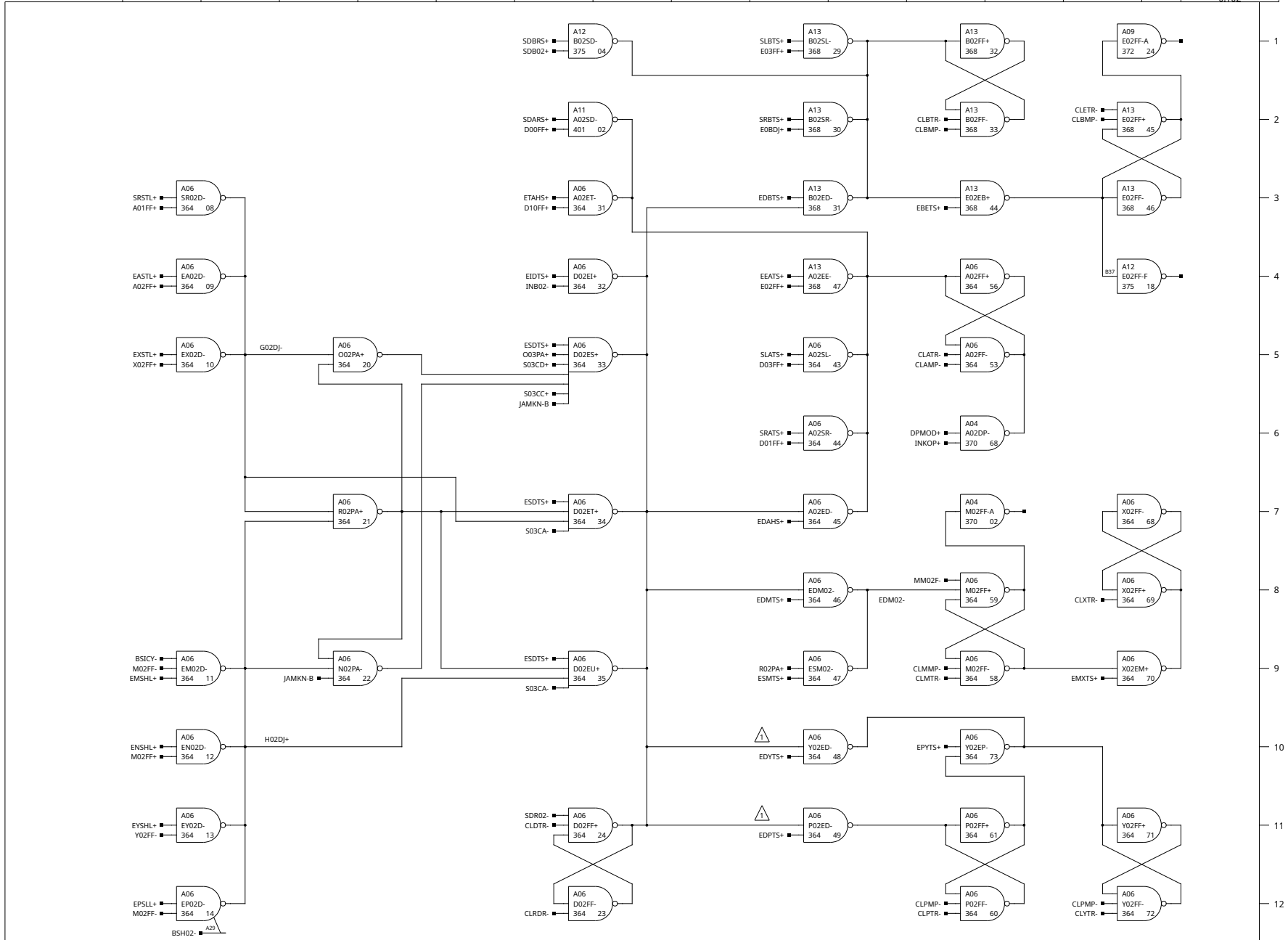

- NOTES-
- ⚠ DELETE D02FF+ AND ADD BSD02+ WITH EXT. ADD OPTION
 - ⚠
 - ⚠
 - ⚠

REV.	A
CHG.	REV. #
S. R. 54-3585	
ECO 7748	
EXT CHANGES SEE ECO 7748	

HONEYWELL
INC
COMPUTER CONTROL DIVISION
Old Connecticut Path, Framingham, Mass

DR. D. HAMEL	DATE
ENG. K. IZBICKI	11-26-68
APP.	7-8-69

PROJECT NO. 55202

TITLE	H-316
COLUMN No. 2	
SIZE	DWG NO.
C	70024486
REV.	B

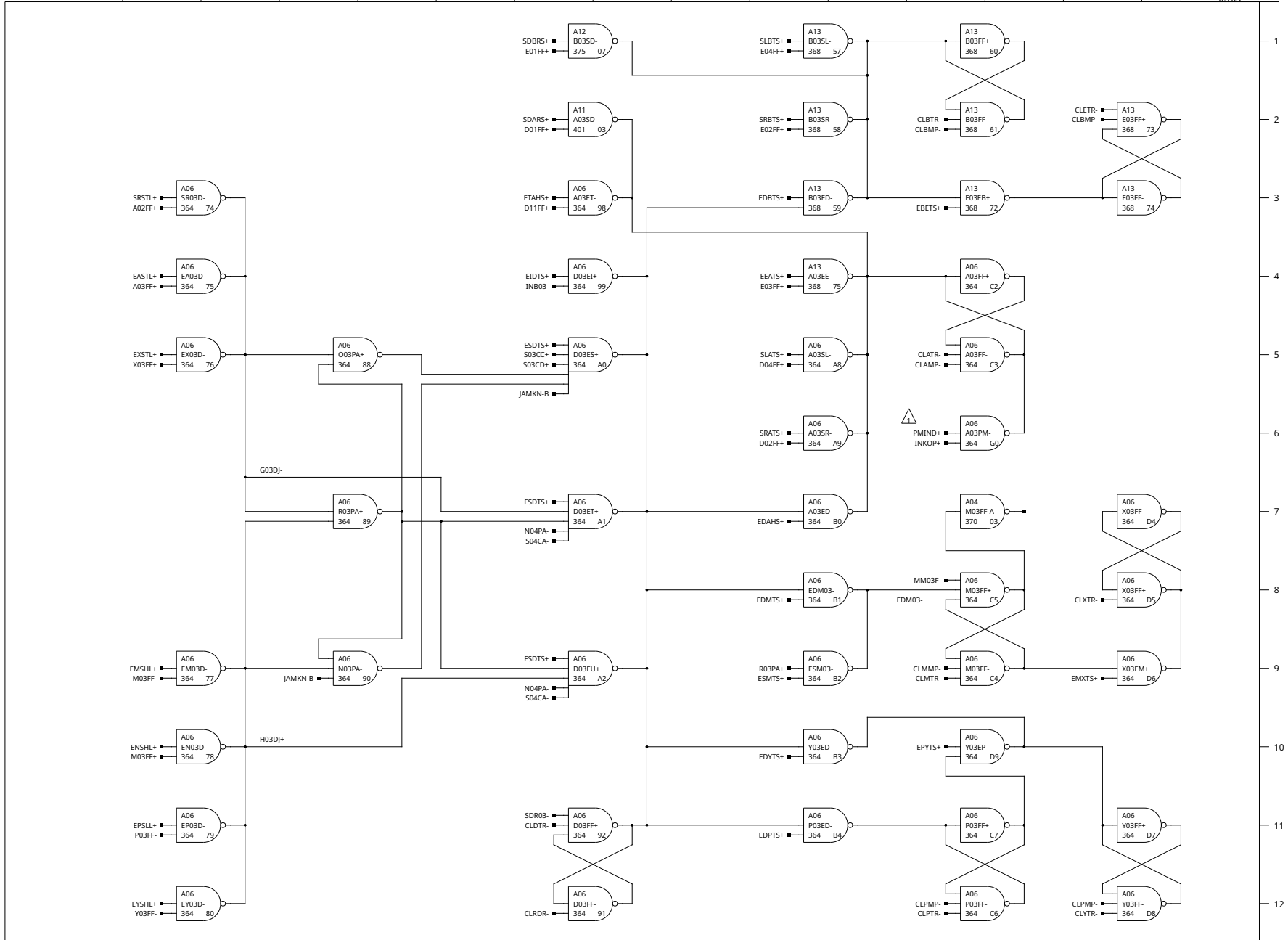

- NOTES-
- △ THIS PT MUST BE GND WITH NO EXT ADD OPTION
 - △
 - △
 - △
 - △

REV.	A
CHG.	REVISIONS
S. R. 54-3585	
N. 8100 (REV. 7/19/78) 03908E	
EXT CHANGES SEE ECO 'A'	

HONEYWELL
 INC
 COMPUTER CONTROL DIVISION
 Old Connecticut Path, Framingham, Mass

DR. D. HAMEL	DATE
ENG. K. IZBICKI	11-26-68
APP.	7-8-69

PROJECT NO. 55202

TITLE	H-316
COLUMN No. 3	
SIZE	DWG NO.
C	70024487
REV.	B

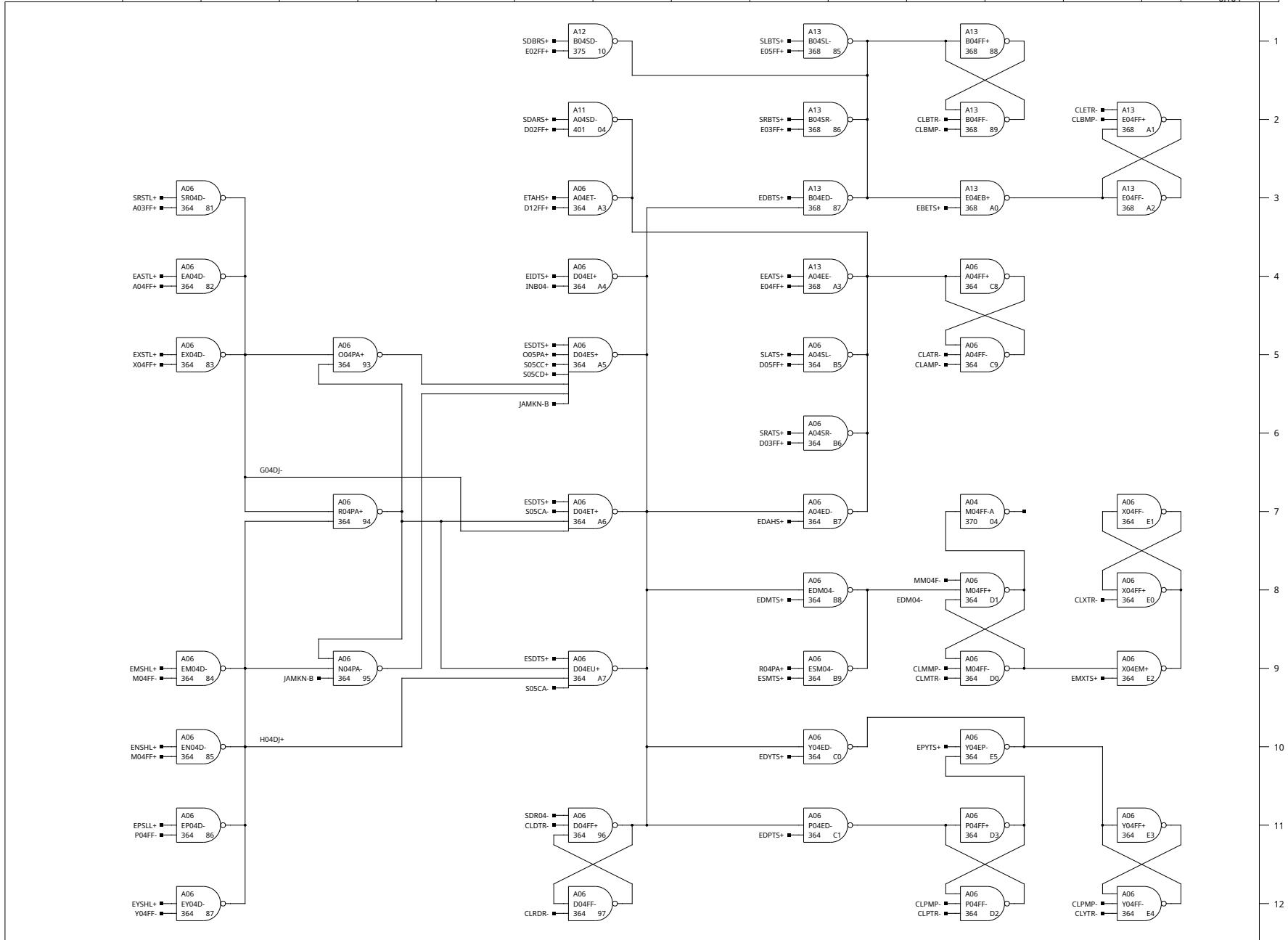

- NOTES-
- △
 - △
 - △
 - △

REV.	DESCRIPTION	DATE
A	ECO 7748	11/19/76
B	ECO 7748	11/19/76
C	ECO 7748	11/19/76
D	ECO 7748	11/19/76
E	ECO 7748	11/19/76
F	ECO 7748	11/19/76
G	ECO 7748	11/19/76
H	ECO 7748	11/19/76
J	ECO 7748	11/19/76
K	ECO 7748	11/19/76
L	ECO 7748	11/19/76
M	ECO 7748	11/19/76
N	ECO 7748	11/19/76
P	ECO 7748	11/19/76

HONEYWELL
INC
COMPUTER CONTROL DIVISION
Old Connecticut Path, Framingham, Mass

DR. D. HAMEL
ENG. K. IZBICKI
APP.

DATE
11-26-68
7-2-69

TITLE	H-316	REV.	B
COLUMN No.	4	SIZE	C
DWG NO.	70024488	PROJECT NO.	55202

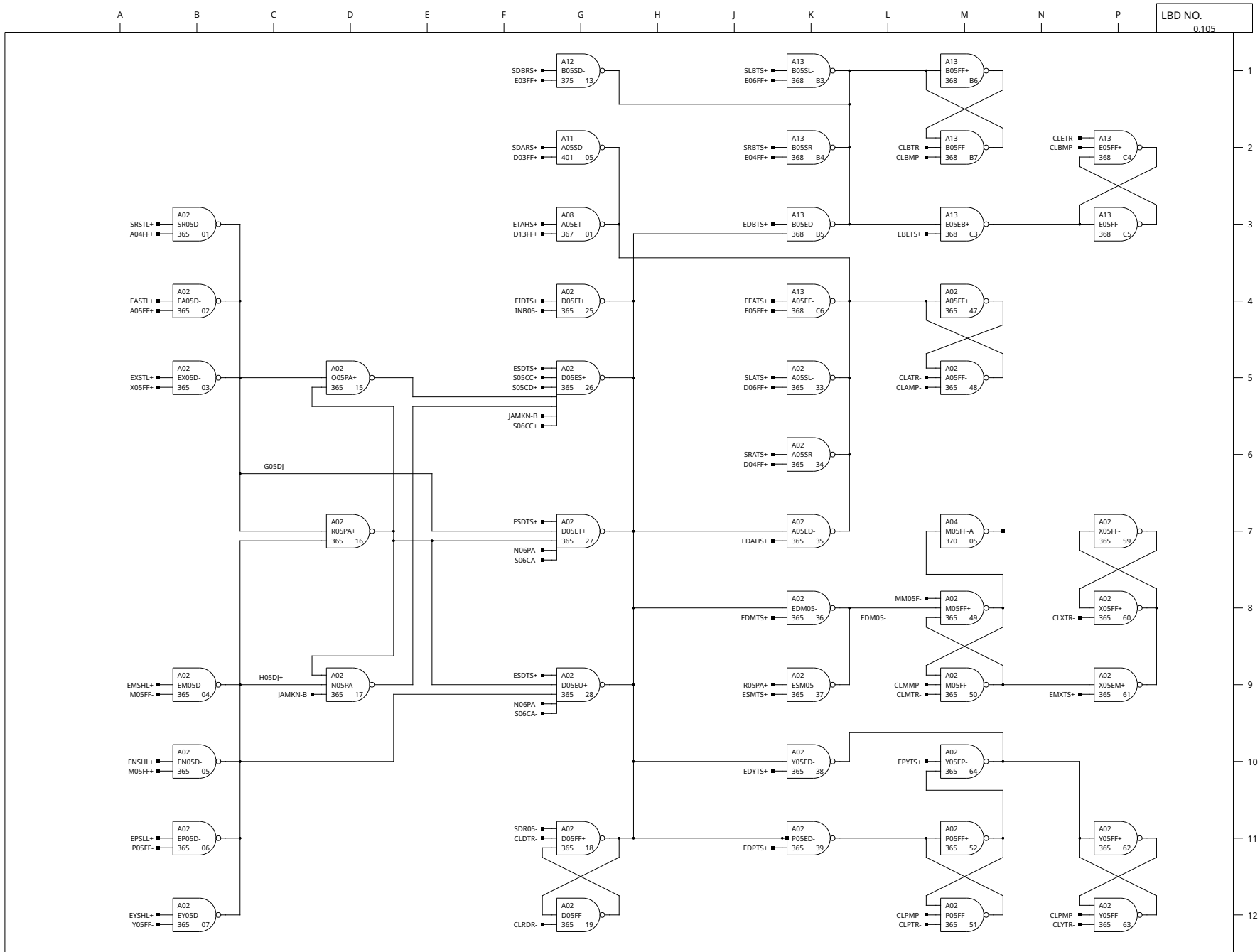

NOTES-

- △
- △
- △
- △

REV.	A						TITLE H-316 COLUMN No. 5	
REVISIONS	1							
CHG.	1	S. R. 54-3585	ECO 7748	11/19/78	DR. D. HAMEL DATE 11-26-68 ENG. K. IZBICKI ADP. 7-2-69		DWG NO. 70024489	REV. B
ECT CHANGES SEE ECO 'A'				PROJECT NO. 55202		SIZE C		

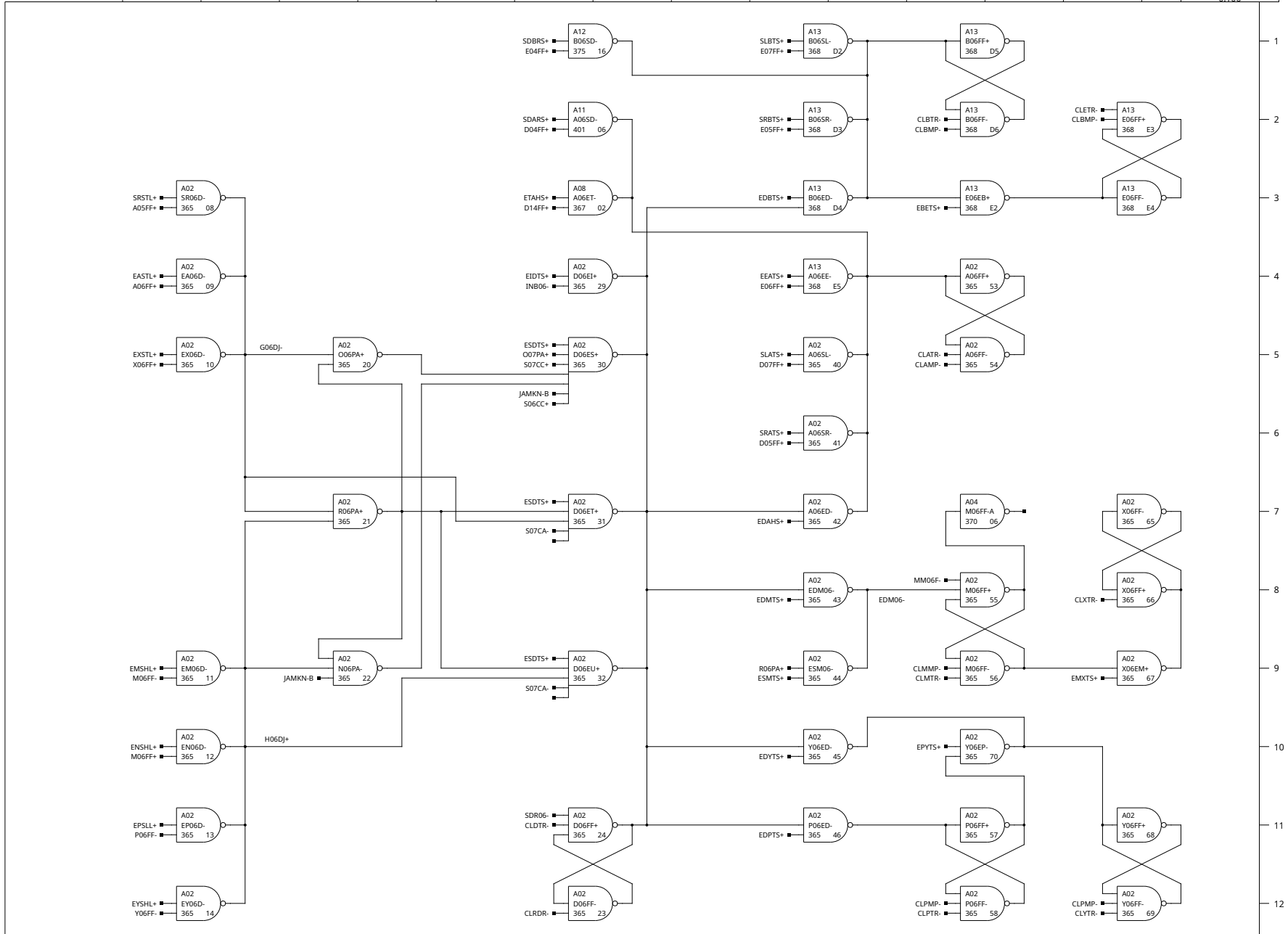

NOTES-
 △
 △
 △
 △

REV.	DESCRIPTION	DATE
A		
B		
C		
D		
E		
F		
G		
H		
J		
K		
L		
M		
N		
P		

S. R. 54-3585
 ECO 7748
 1/19/76
 EXT CHANGES SEE ECO 7A

HONEYWELL
 INC
 COMPUTER CONTROL DIVISION
 Old Connecticut Path, Framingham, Mass

DR. D. HAMEL DATE
 ENG. K. IZBICKI 11-26-68
 ADP. 7-2-69

TITLE H-316 COLUMN No. 6	SIZE C	DWG NO. 70024490	REV. B
--------------------------------	-----------	---------------------	-----------

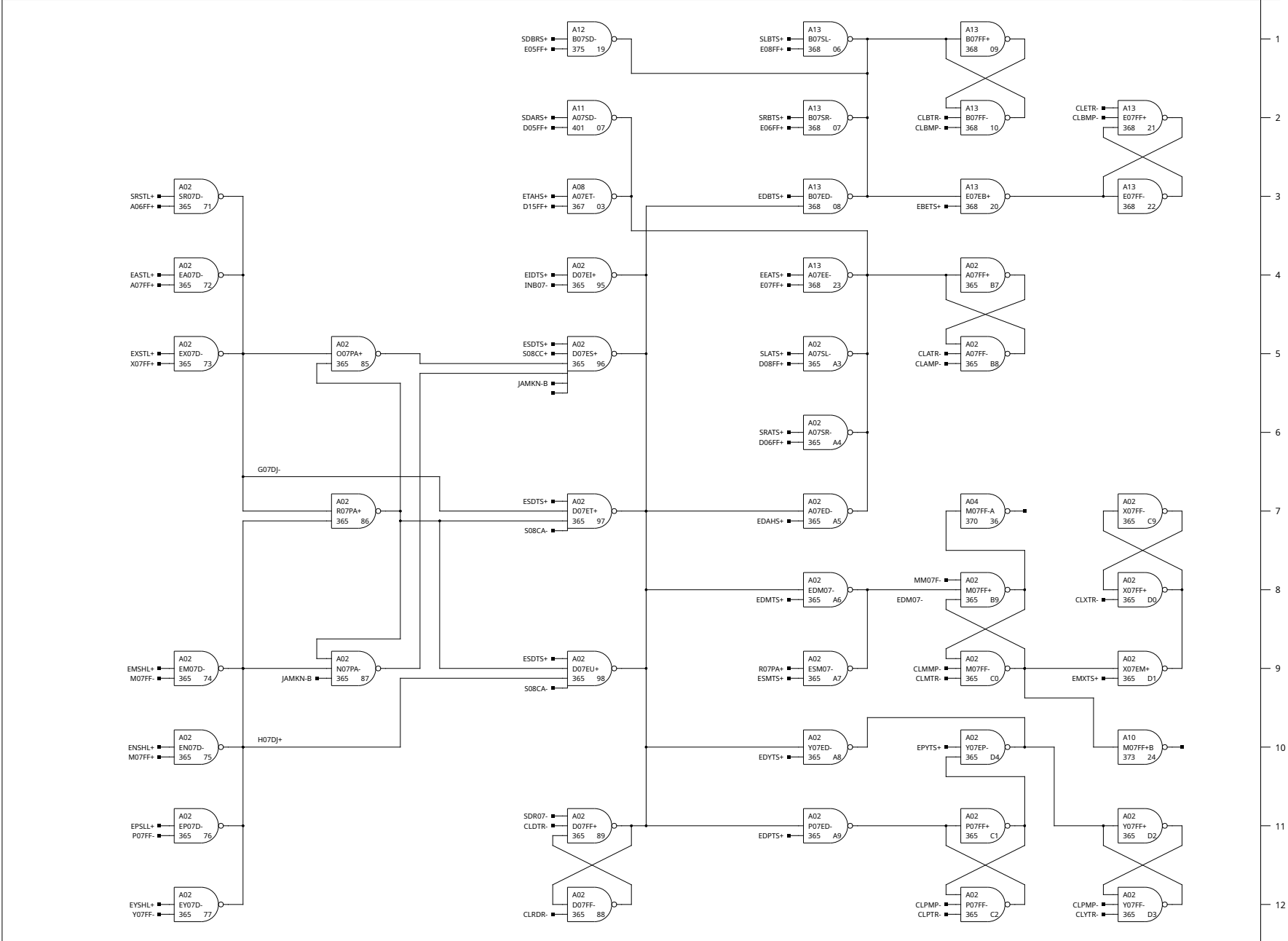

NOTES-

- △
- △
- △
- △

REV.	REVISIONS	DATE
A	ECO 7748 S. R. 54-3585	11/19/78
B	ECO 7748 EOT CHANGES SEE ECO 7748	

HONEYWELL
INC
COMPUTER CONTROL DIVISION
Old Connecticut Path, Framingham, Mass

DR. D. HAMEL
ENG. K. IZBICKI
APP. _____

DATE
11-26-68
7-2-69

TITLE	H-316	REV.	B
COLUMN No.	7	SIZE	C
DWG NO.	70024491		

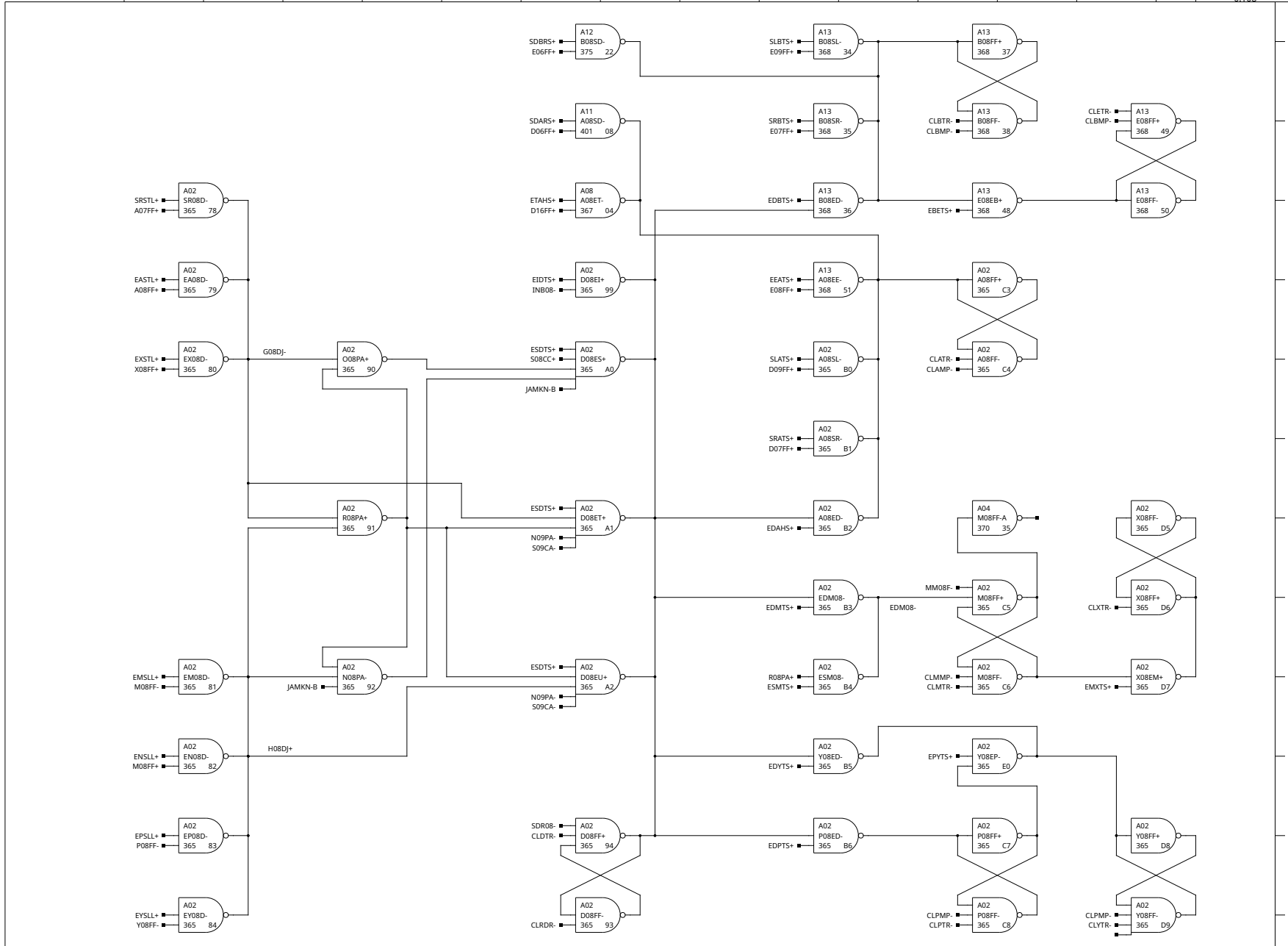

NOTES-
 △
 △
 △
 △

REV.	A
CHG.	REVISIONS
DATE	11/19/76
BY	S. R. 54-3585
CHK	ECO 7748
	EXT CHANGES SEE ECO 7748

HONEYWELL
 INC
 COMPUTER CONTROL DIVISION
 Old Connecticut Path, Framingham, Mass

DR. D. HAMEL	DATE
ENG. K. IZBICKI	11-26-68
APP.	7-2-69

PROJECT NO. 55202

TITLE	H-316
	COLUMN No. 8
SIZE	DWG NO.
C	70024492
REV.	B

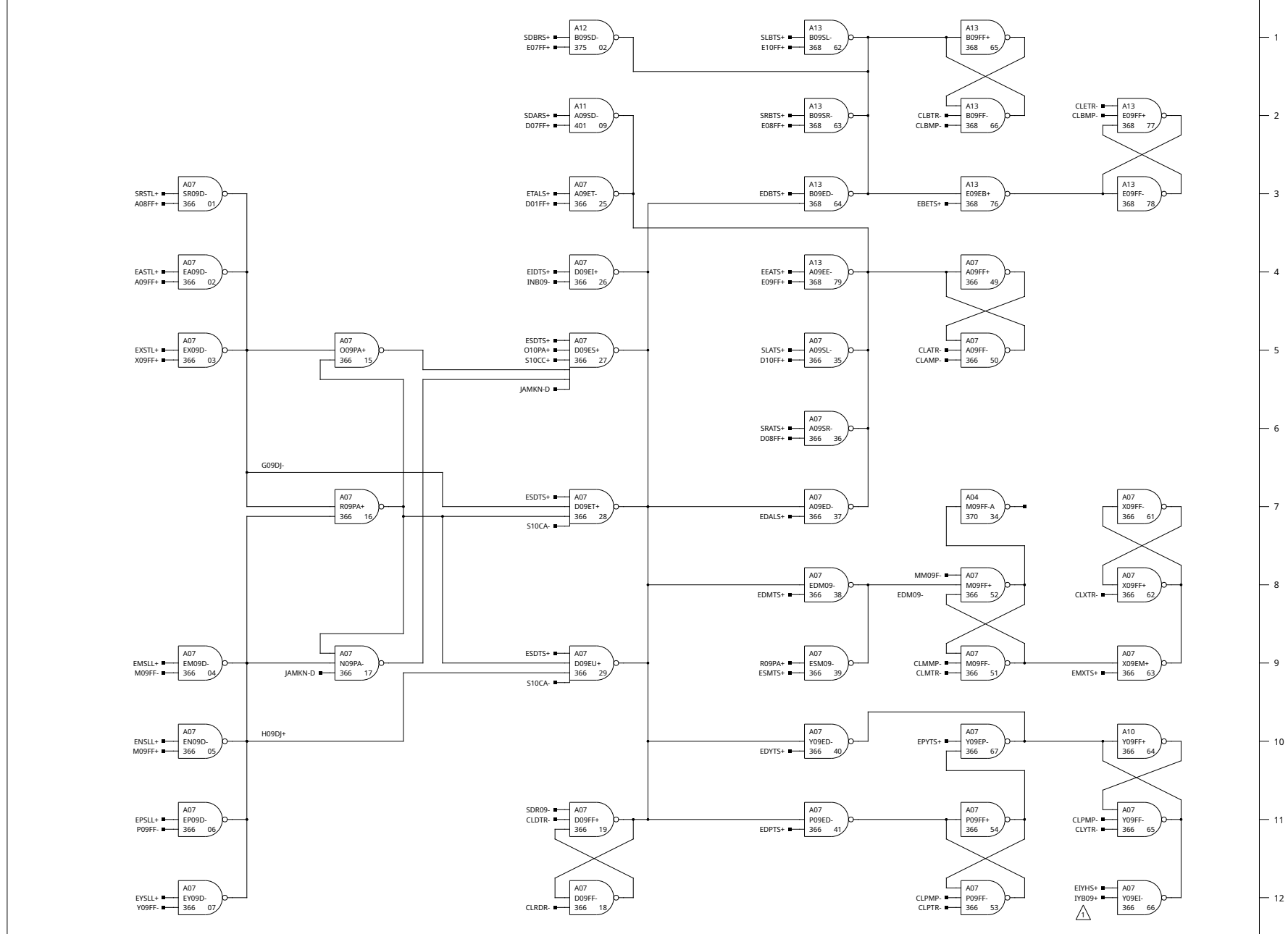

- NOTES-
- △ THIS PT. IS GND WITH NO DMC OPTION
 - △
 - △
 - △

REV.	DESCRIPTION	DATE
A	ECO 7748	11/19/76
B	ECO 7748	11/19/76
C	ECO 7748	11/19/76
D	ECO 7748	11/19/76
E	ECO 7748	11/19/76
F	ECO 7748	11/19/76
G	ECO 7748	11/19/76
H	ECO 7748	11/19/76
J	ECO 7748	11/19/76
K	ECO 7748	11/19/76
L	ECO 7748	11/19/76
M	ECO 7748	11/19/76
N	ECO 7748	11/19/76
P	ECO 7748	11/19/76

HONEYWELL
INC
COMPUTER CONTROL DIVISION
Old Connecticut Path, Framingham, Mass

DR. D. HAMEL	DATE
ENG. K. IZBICKI	11-26-68
APP.	7-2-69

PROJECT NO. 55202

TITLE	H-316
COLUMN No.	9
SIZE	DWG NO.
C	70024493
REV.	B

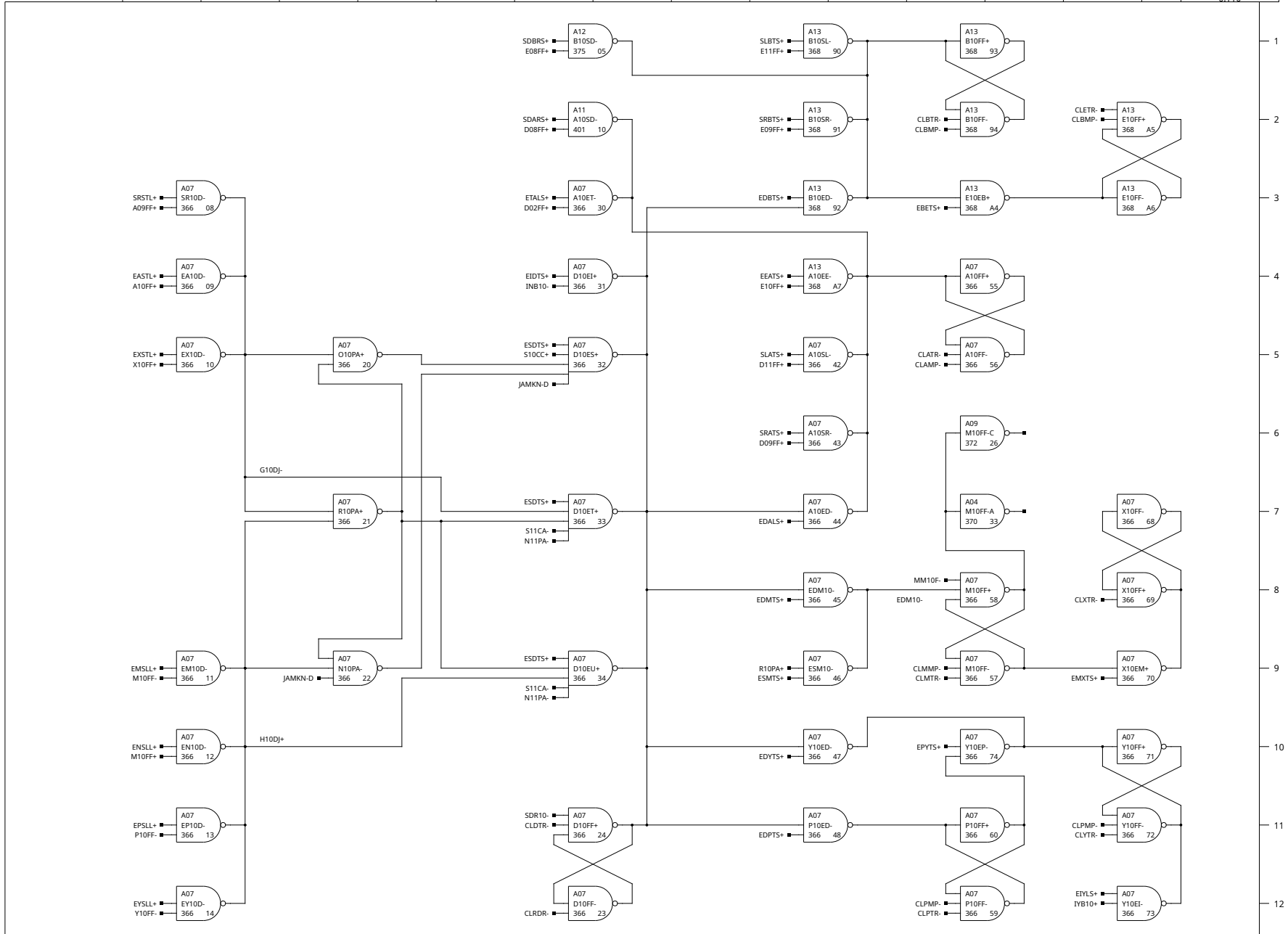

NOTES:
 △
 △
 △
 △

REV.	DESCRIPTION	DATE
A	S. R. 54-3585	11/19/76
B	ECO 7748	
	EXT CHANGES SEE ECO 7748	

HONEYWELL
 INC
 COMPUTER CONTROL DIVISION
 Old Connecticut Path, Framingham, Mass

DR. D. HAMEL	DATE
ENG. K. IZBICKI	11-26-68
APP.	7-2-69

PROJECT NO. 55202

TITLE	H-316
COLUMN No.	10
SIZE	DWG NO.
C	70024494
REV.	B

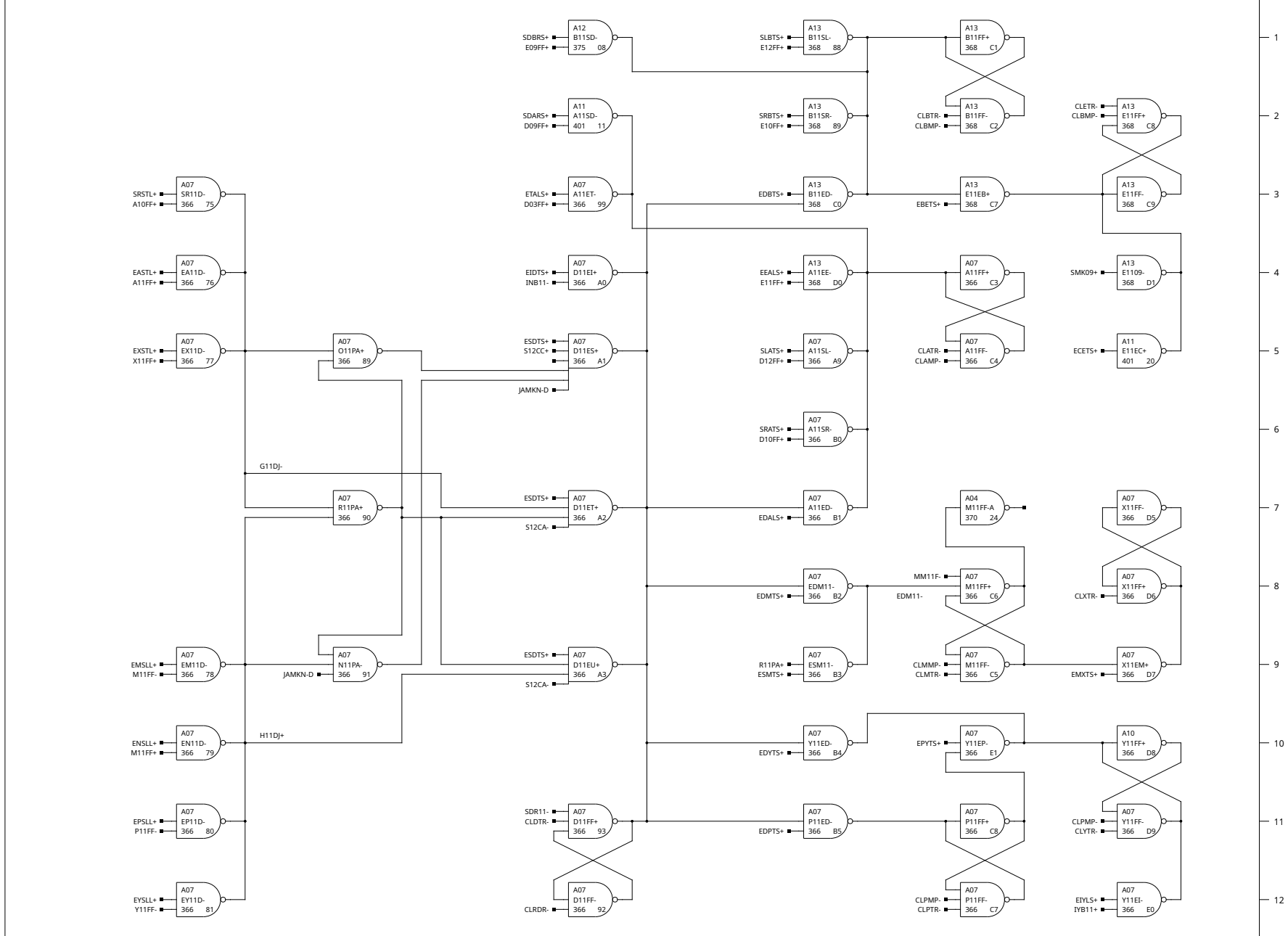

NOTES:
 ▲
 ▲
 ▲
 ▲

REV.	A
CHG.	REVISIONS
NO.	S. R. 54-3585
DATE	1/19/76
BY	ECO 7748
CHKD	EXT CHANGES SEE ECO 7A

HONEYWELL
 INC
 COMPUTER CONTROL DIVISION
 Old Connecticut Path, Framingham, Mass

DR. D. HAMEL	DATE
ENG. K. IZBICKI	11-25-68
APP.	7-2-69

PROJECT NO. 55202

TITLE	H-316
	COLUMN No. 11
SIZE	DWG NO.
C	70024495
REV.	B

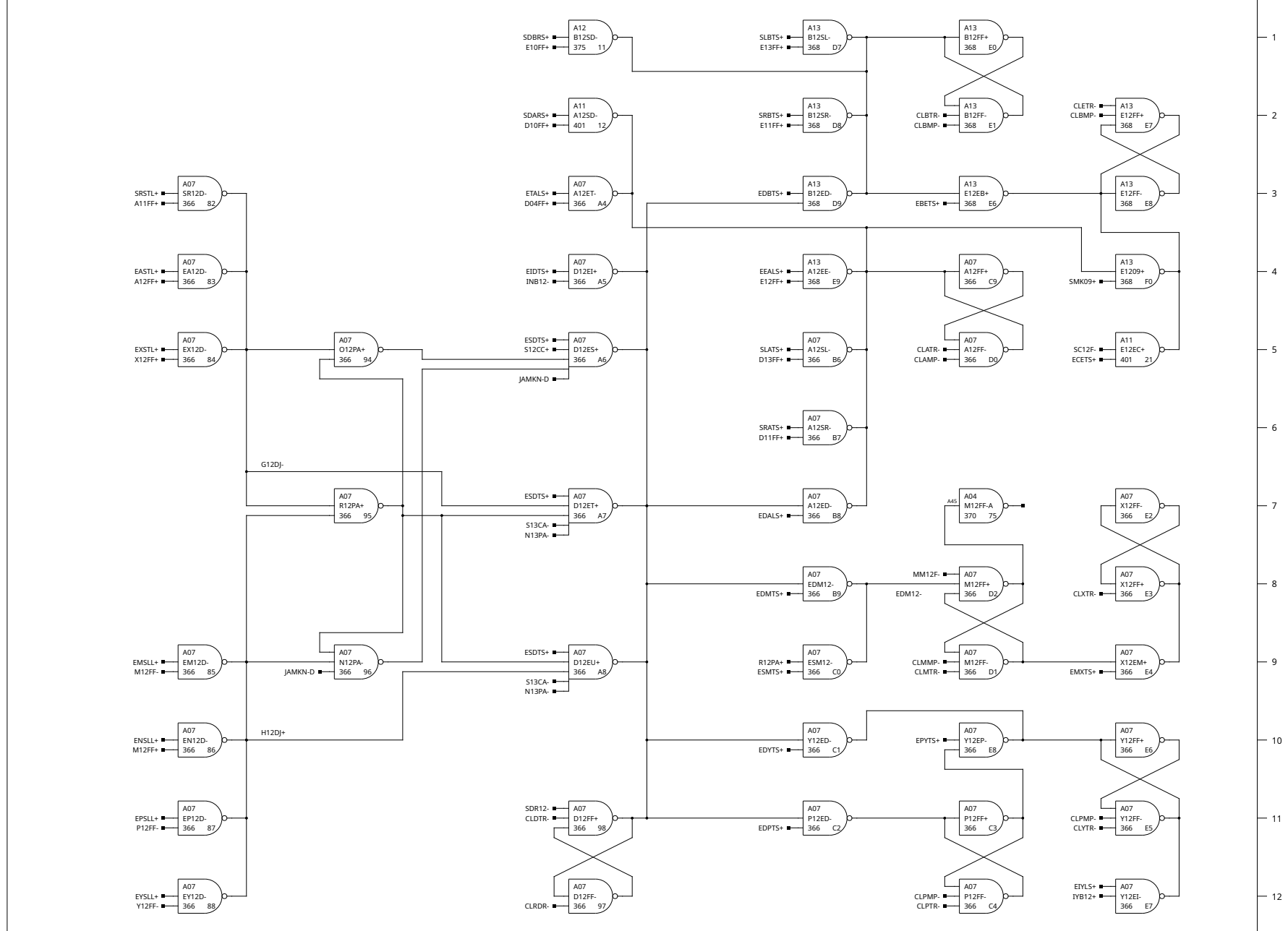

NOTES-
 ▲
 ▲
 ▲
 ▲

REV.	A
REVISIONS	
NO.	S. R. 54-3585
DATE	11/19/76
ECO 7748	
EXT CHANGES	SEE ECO 7748

HONEYWELL
 INC
 COMPUTER CONTROL DIVISION
 Old Connecticut Path, Framingham, Mass

DR. D. HAMEL	DATE
ENG. K. IZBICKI	11-26-68
APP.	7-2-69

PROJECT NO. 55202

TITLE	H-316
	COLUMN No. 12
SIZE	DWG NO.
C	70024496
REV.	B

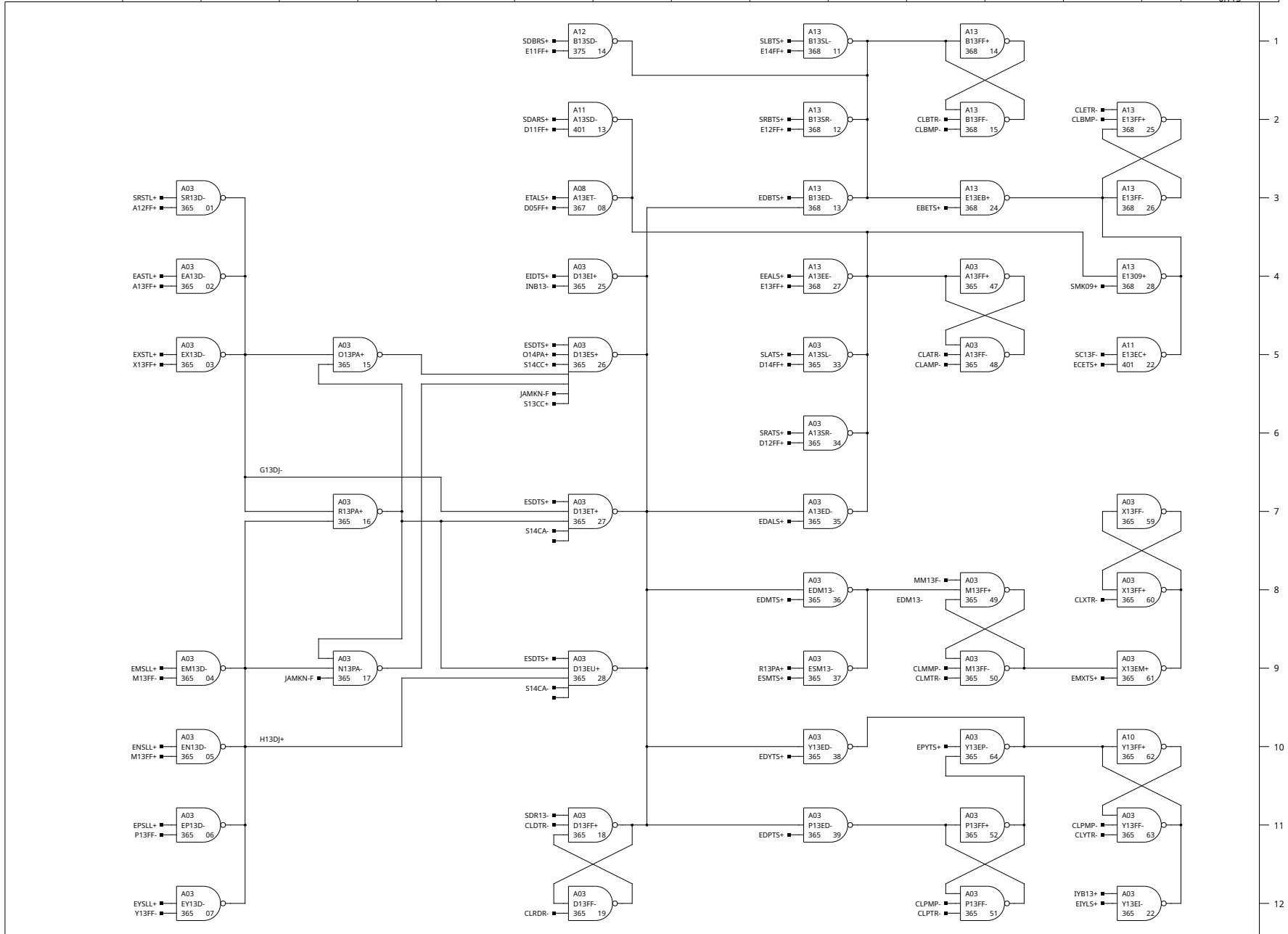

NOTES:
 △
 △
 △
 △

REV	A
CHG	
REVISIONS	
	S. R. 54-3585
	ECO 7748
	EXT CHANGES SEE ECO 7A
	1/1/978

HONEYWELL
 INC
 COMPUTER CONTROL DIVISION
 Old Connecticut Path, Framingham, Mass

DR. D. HAMEL	DATE
ENG. K. IZBIKCI	11-26-68
APP.	7-2-69

PROJECT NO. 55202

TITLE
 H-316
 COLUMN No. 13

SIZE DWG NO. REV.
 C 70024497 B

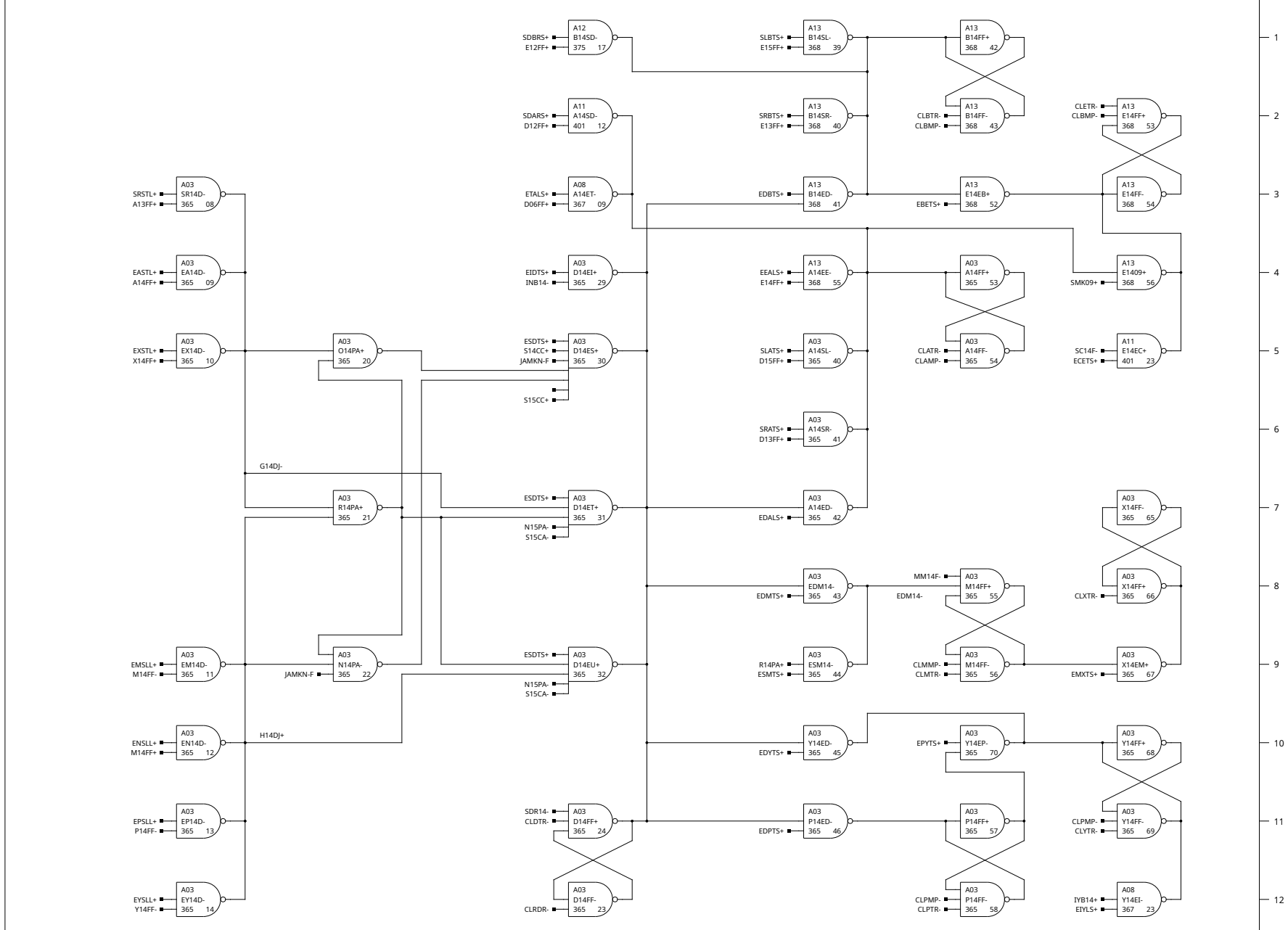

NOTES:
 ▲
 ▲
 ▲
 ▲

REV.	A
CHG.	REV.
NO.	NO.
S. R. 54-3585	
ECO 7748	
EXT CHANGES SEE ECO 7748	

HONEYWELL
 INC
 COMPUTER CONTROL DIVISION
 Old Connecticut Path, Framingham, Mass

DR. D. HAMEL	DATE
ENG. K. IZBICKI	11-26-68
APP.	7-2-69

PROJECT NO. 55202

TITLE	H-316
COLUMN No.	12
SIZE	DWG NO.
C	70024498
REV.	B

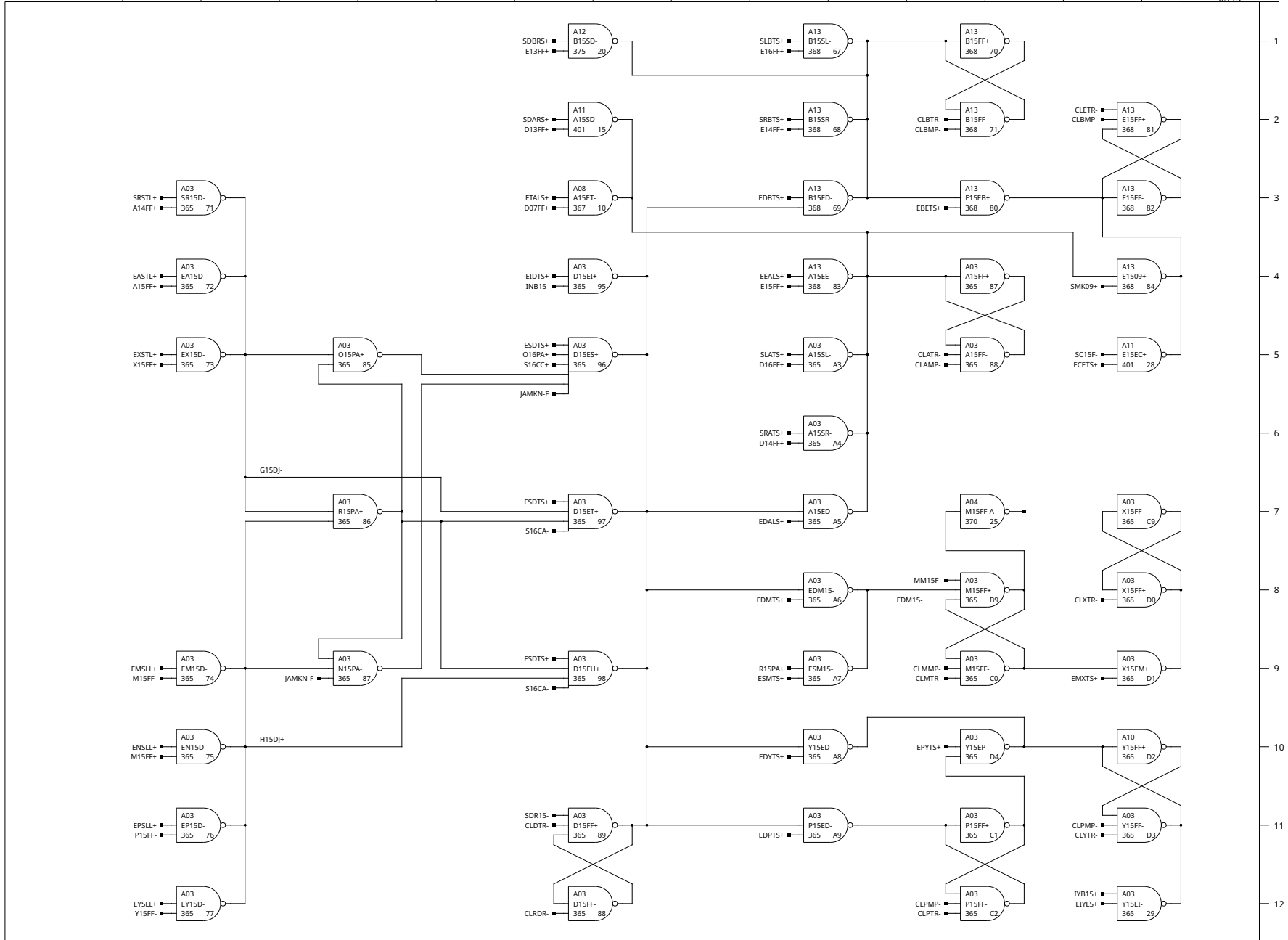

NOTES-
 ▲
 ▲
 ▲
 ▲

REV.	DATE	BY	CHKD.
A	11/19/76		
B			
C			
D			
E			
F			
G			
H			
J			
K			
L			
M			
N			
P			

HONEYWELL
 INC
 COMPUTER CONTROL DIVISION
 Old Connecticut Path, Framingham, Mass

DR. D. HAMEL	DATE
ENG. K. IZBICKI	11-26-68
APP.	7-2-69

PROJECT NO. 55202

TITLE	H-316
COLUMN No.	15
SIZE	DWG NO.
C	70024499
REV.	B

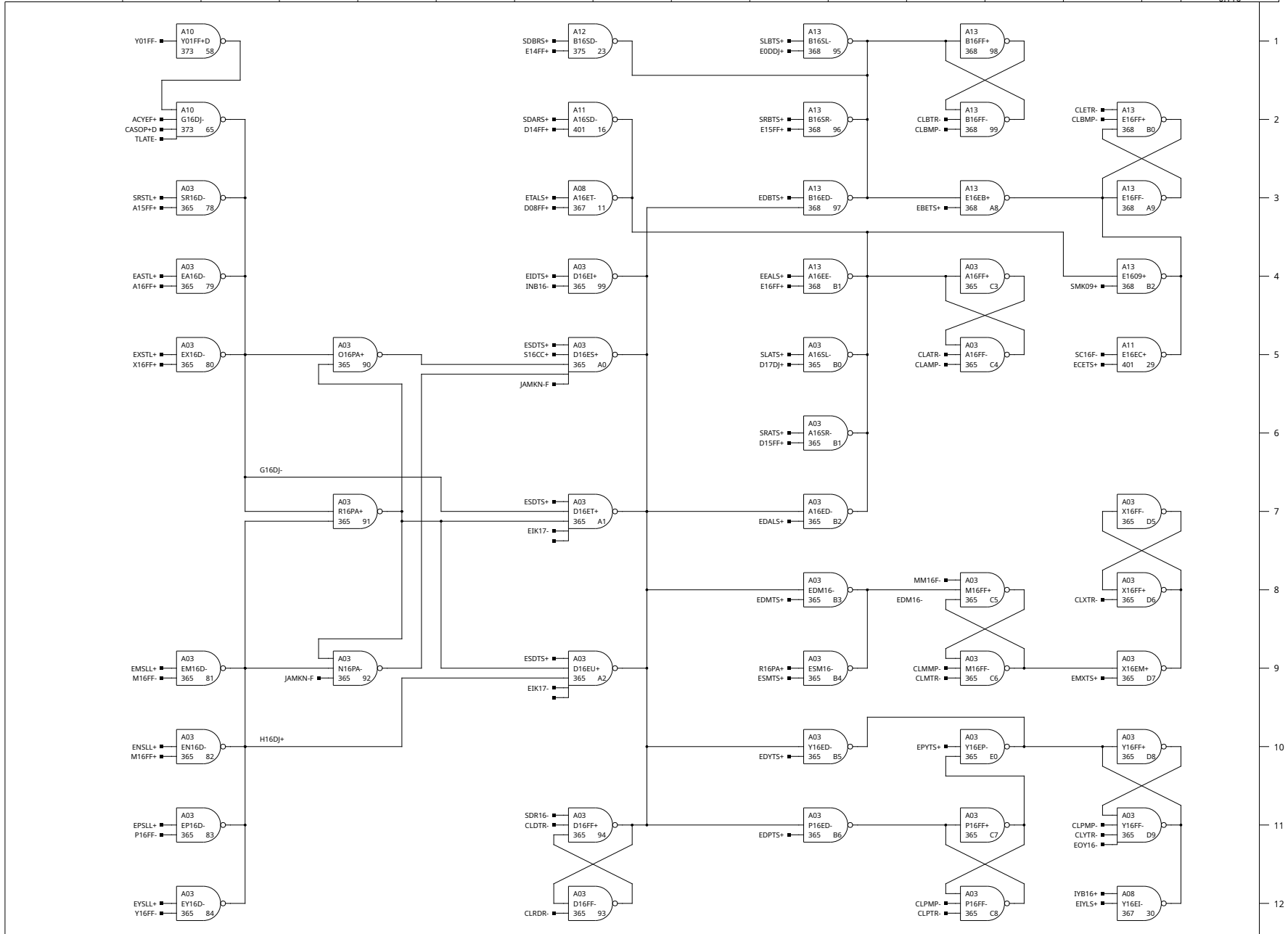

NOTES-
 ▲
 ▲
 ▲
 ▲

REV.	A
CHG.	REVISIONS
NO.	1
DATE	11/19/76
BY	S. R. 54-3585
CHKD.	ECO 7748
APP.	EXT CHANGES SEE ECO 7748

HONEYWELL
 INC
 COMPUTER CONTROL DIVISION
 Old Connecticut Path, Framingham, Mass

DR. D. HAMEL	DATE
ENG. K. IZBICKI	11-26-68
APP.	7-2-69

PROJECT NO. 55202

TITLE	H-316
	COLUMN No. 16
SIZE	DWG NO.
C	70024500
REV.	B

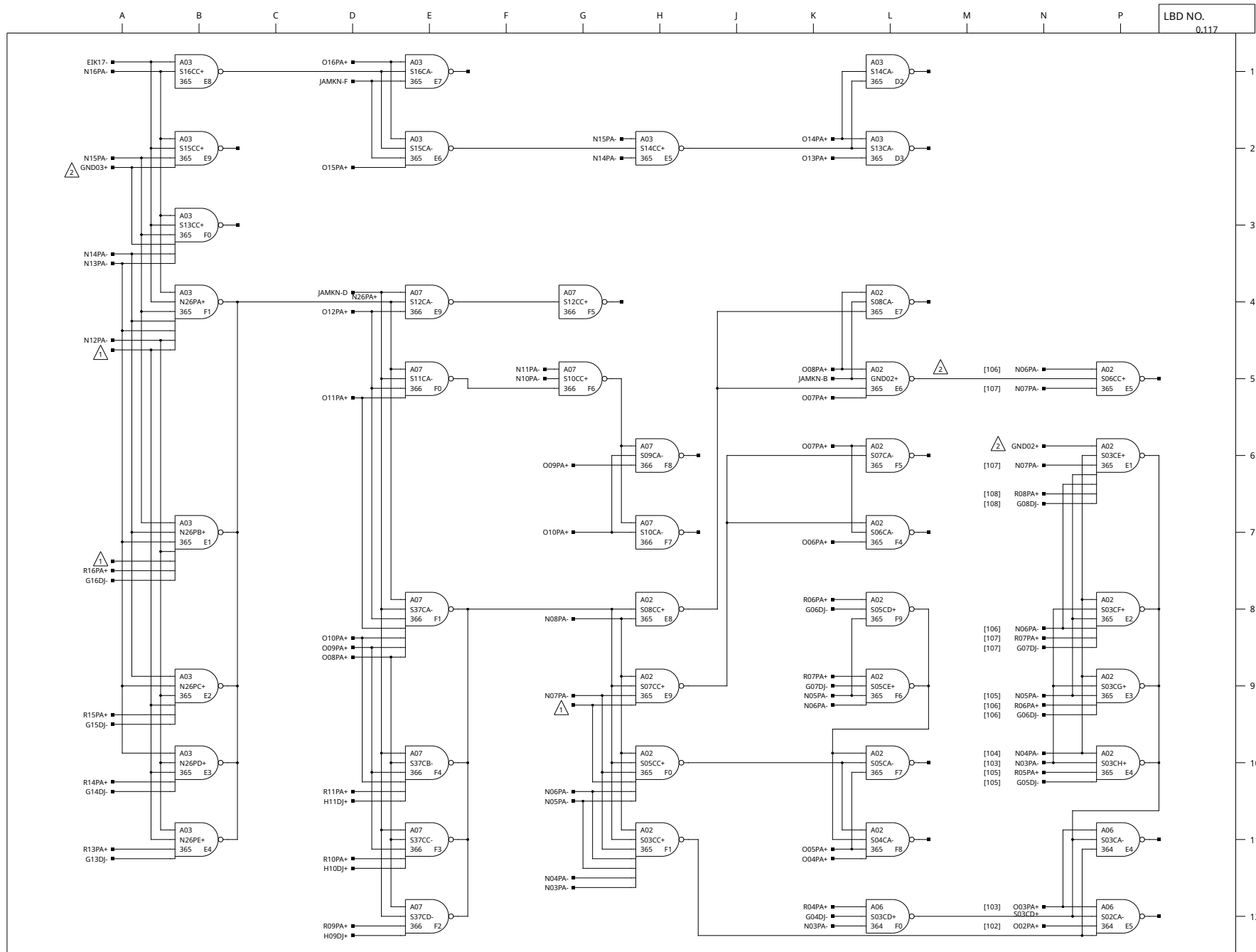

LBD NO.
0.117

NOTES-

- △ THESE PTS ARE FLOATING. THIS IS DUE TO THE DOUBLE USAGE OF CC365
- △ THESE PTS ARE TIED TO THEIR PAC GROUNDS. THIS IS DUE TO THE DOUBLE USAGE OF CC365
- △
- △

REV.	A
CHG.	
REVISIONS	
S. R. 54-3585	
ECO 7748	1/19/76
EAT CHANGES SEE ECO 7748	

HONEYWELL
INC
COMPUTER CONTROL DIVISION
Old Connecticut Path, Framingham, Mass

DR. D. HAMEL	DATE
ENG. K. IZBICKI	11-27-1968
APP.	4-1-69

PROJECT NO. 55202

TITLE	H-316
CARRY NETWORK	
SIZE	DWG NO.
C	70024501
REV.	B

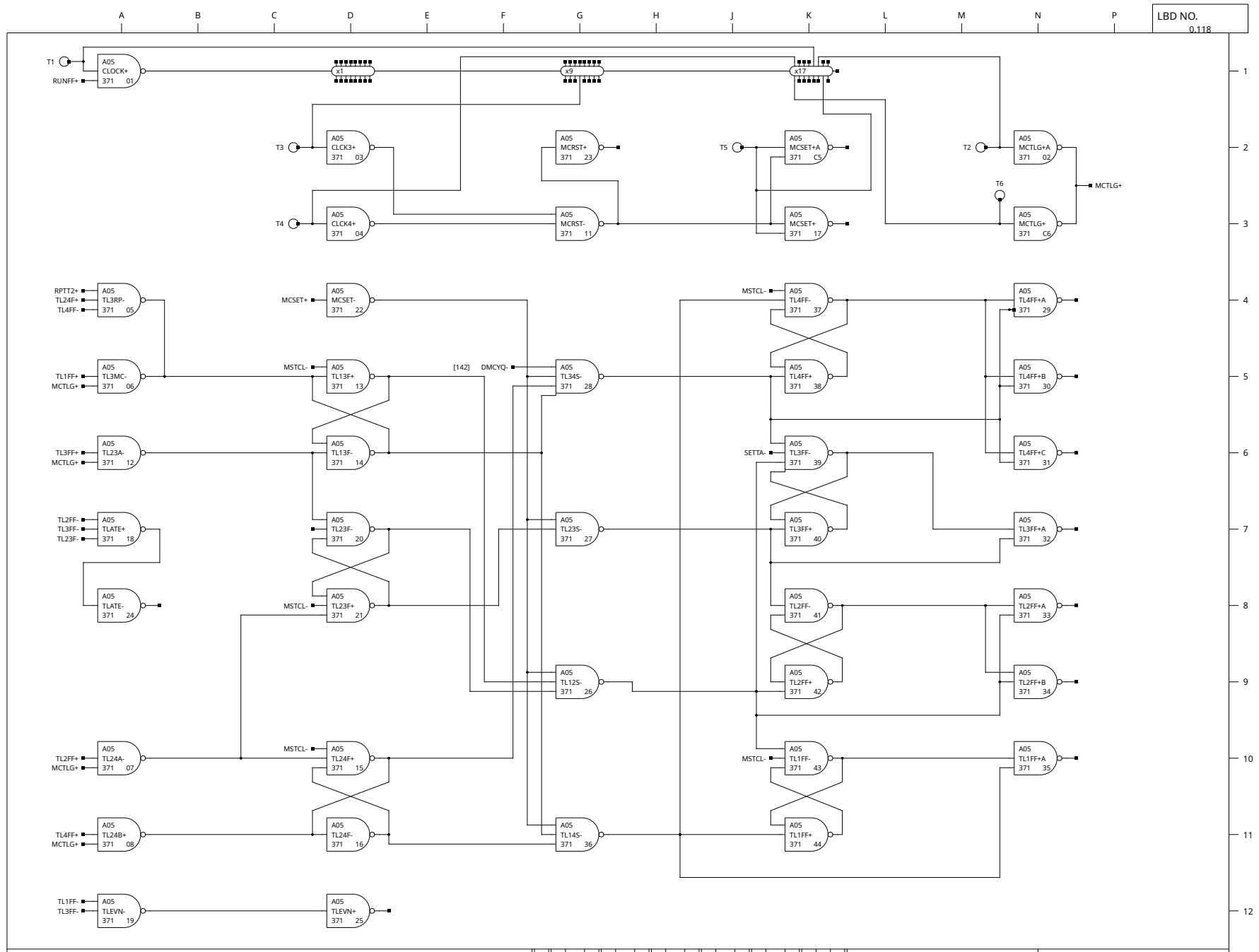

LBD NO.
0.118

NOTES-

- △
- △
- △
- △

REV.	A
CHG.	REV.
NO.	NO.
S. R. 54-3585	
ECO 7748	11/19/76
EXT CHANGES SEE ECO 7748	

HONEYWELL
INC
COMPUTER CONTROL DIVISION
Old Connecticut Path, Framingham, Mass

DR. D. HAMEL	DATE
ENG. K. IZBIKLI	1-9-1969
APP.	7-2-69

PROJECT NO. 55202

TITLE	H-316
	TLG AND CLOCK
SIZE	DWG NO.
C	70024502
REV.	B

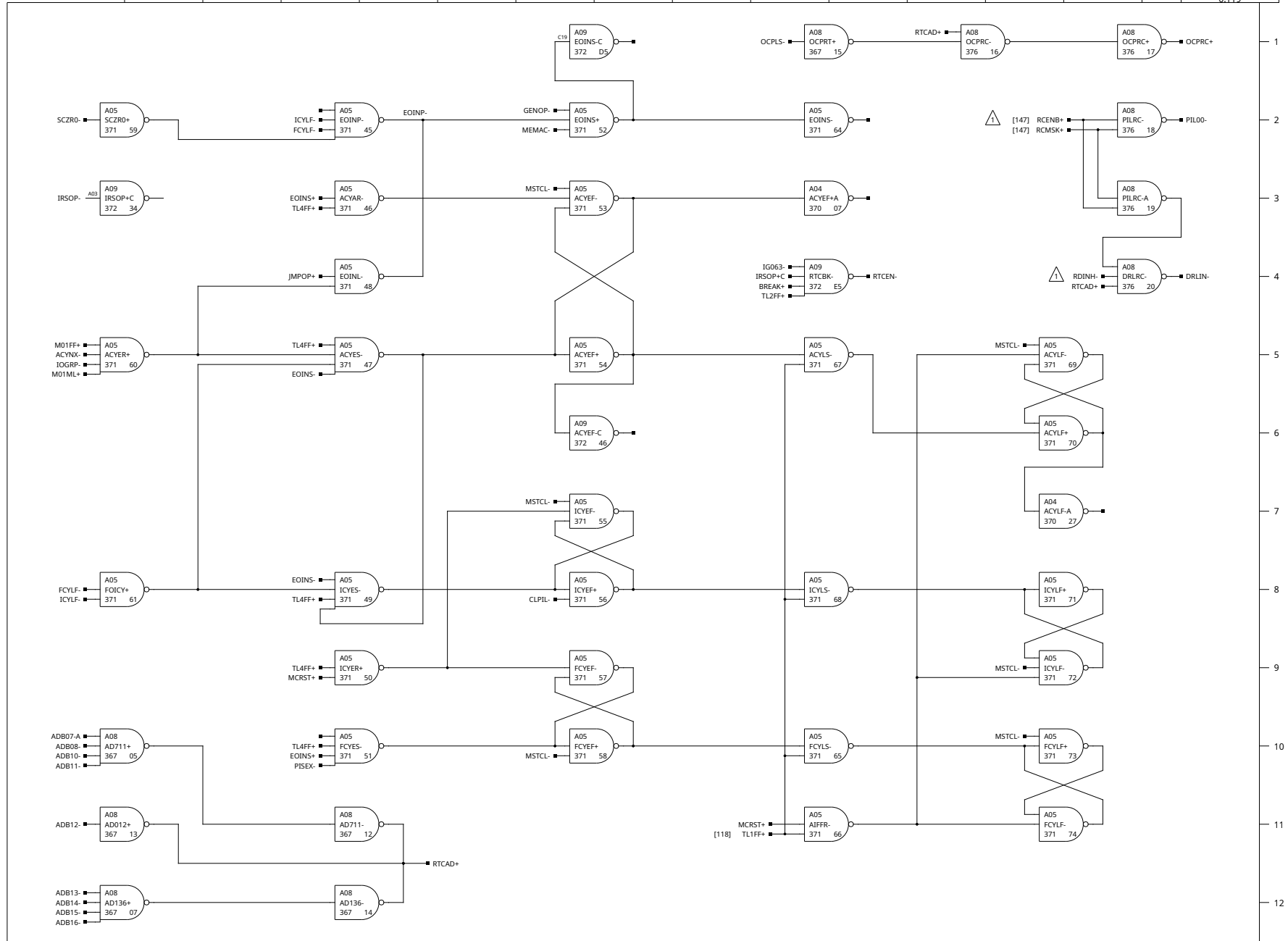

NOTES-

- ⚠ REMOVE GROUND WHEN USING REAL TIME CLOCK
- ⚠
- ⚠
- ⚠

REV.	DESCRIPTION
A	
B	
C	
D	
E	
F	
G	
H	
J	
K	
L	
M	
N	
P	

S. R. 54-3585
 ECO 7748
 1/19/76
 EXT CHANGES SEE ECO 7748

HONEYWELL
 INC
 COMPUTER CONTROL DIVISION
 Old Connecticut Path, Framingham, Mass

DR. D. HAMEL	DATE
ENG. K. IZBICKI	12-12-1968
APP.	4-1-69

PROJECT NO. 55202

TITLE	H-316	REV.	B
	PHASE REGISTER		
SIZE	DWG NO.		
C	70024503		

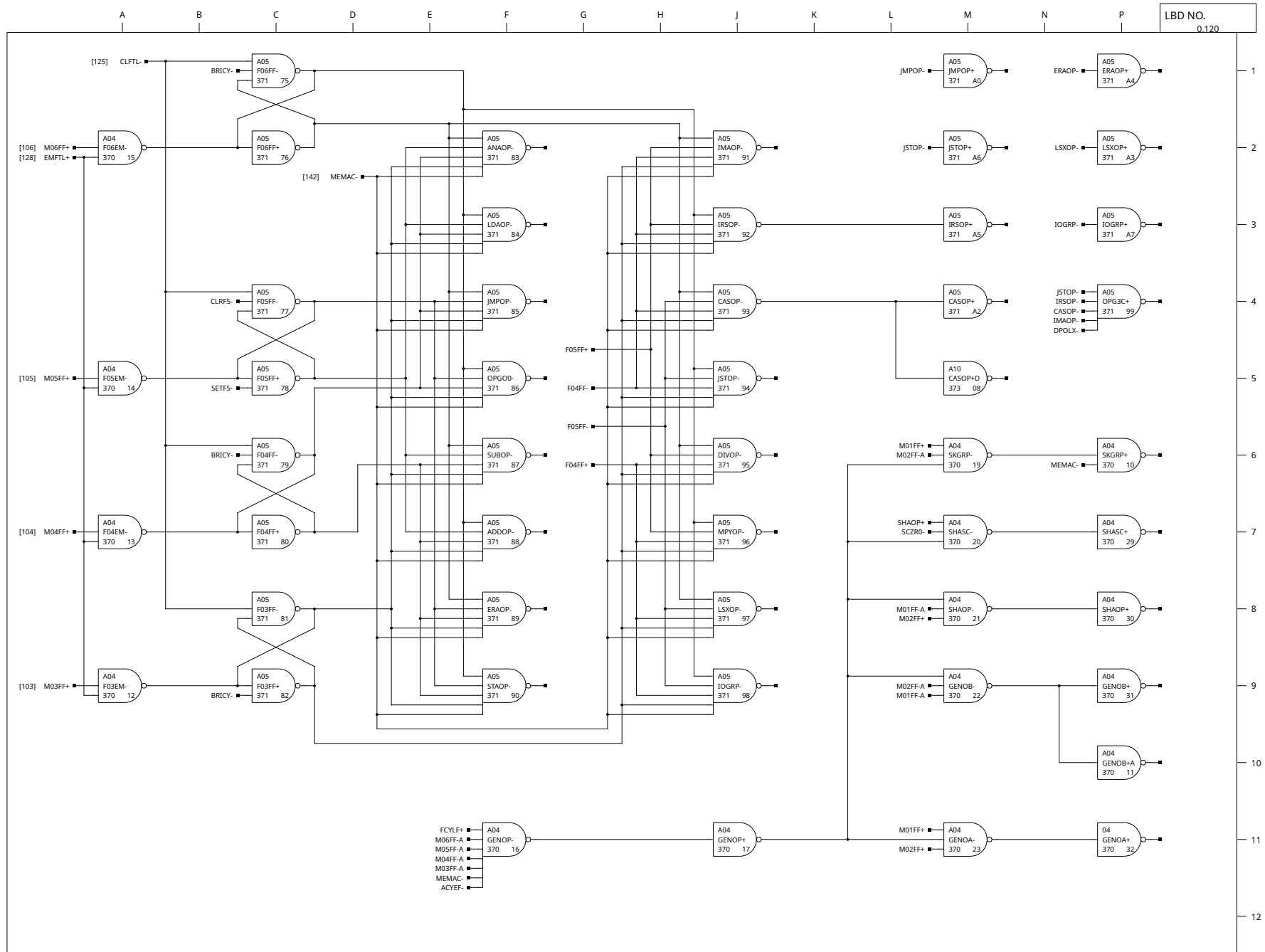

LBD NO.
0.120

NOTES:
△
△
△
△

CHK	REV	REVISIONS
	A	
	B	

S. R. 54-3585

ECO 7748

BY CHANGES

SEE ECOLLA

HONEYWELL
INC
COMPUTER CONTROL DIVISION
Old Connecticut Path, Framingham, Mass

DR. D. HAMEL	DATE
ENG. K. IZBICKI	13-12-68
APP.	17-2-69

PROJECT NO. 55202

TITLE	H-316
F REG & OP DECODE	
SIZE	DWG NO.
C	70024504
REV.	B

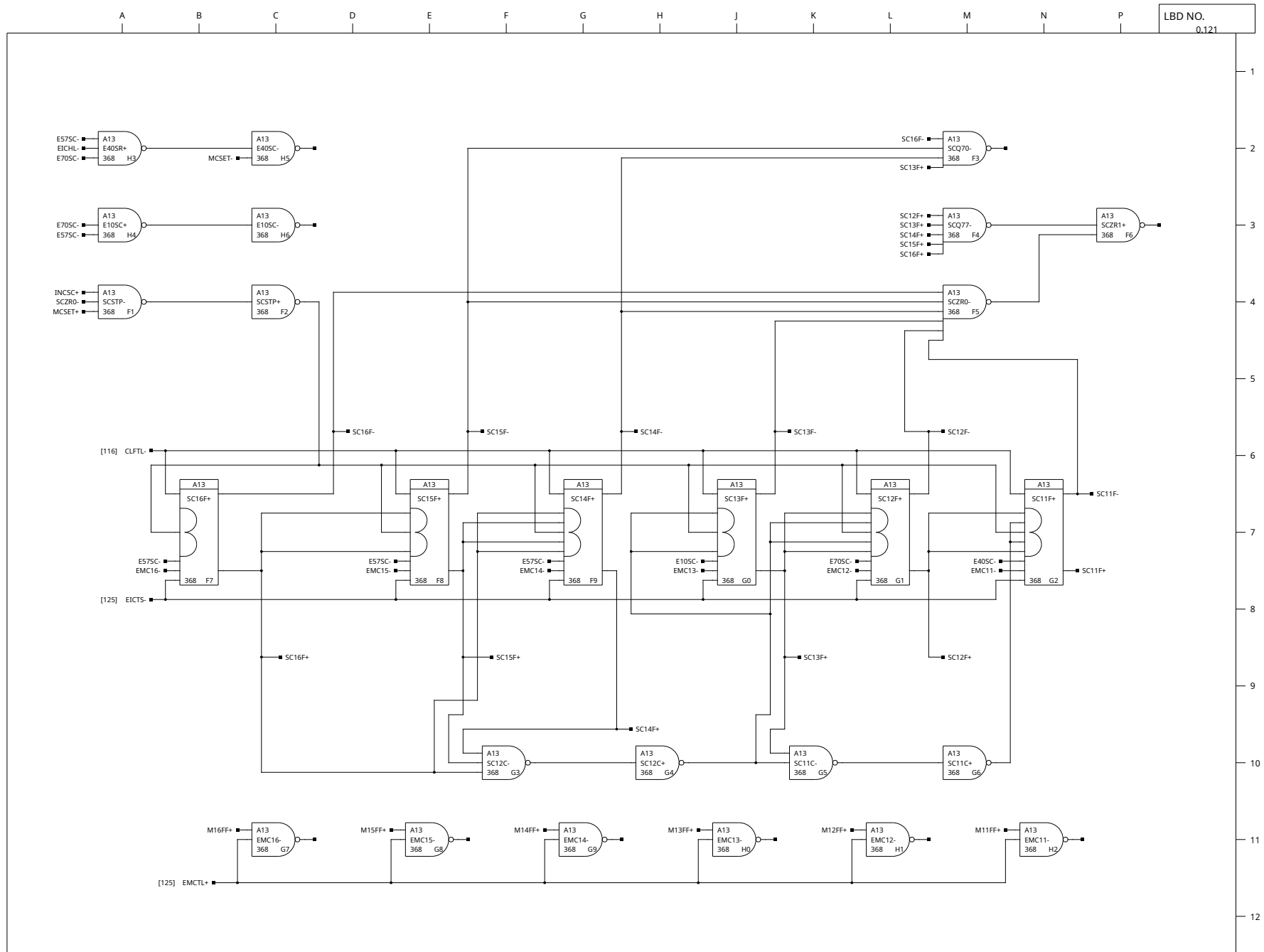

LBD NO.
0.121

NOTES-

- △
- △
- △
- △

REV.	DESCRIPTION
A	
B	
C	
D	
E	
F	
G	
H	
J	
K	
L	
M	
N	
P	

HONEYWELL
INC
COMPUTER CONTROL DIVISION
Old Connecticut Path, Framingham, Mass

DR. D. HAMEL	DATE
ENG. K. IZBICKI	12-20-1968
APP.	17-2-69

PROJECT NO. 55202

TITLE	H-316
	SHIFT COUNTER
SIZE	DWG NO.
C	70024505
REV.	B

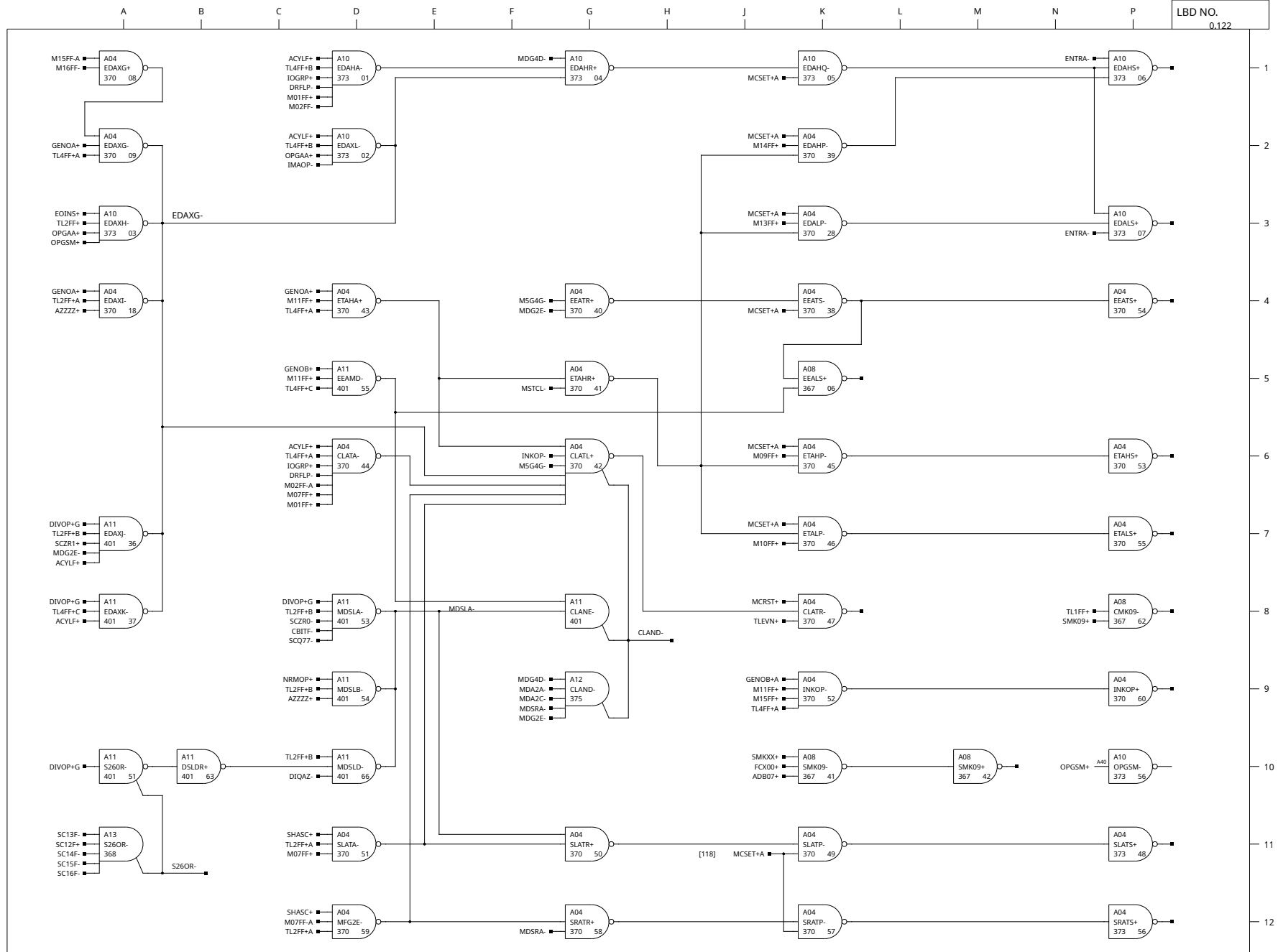

NOTES-
 ▲
 ▲
 ▲
 ▲

REV.	DATE	BY	CHKD.
A			
B			

S. R. 54-3585
 ECO 7748
 EXT CHANGES SEE ECO 7748

HONEYWELL
 INC
 COMPUTER CONTROL DIVISION
 Old Connecticut Path, Framingham, Mass

DR. D. HAMEL
 ENG. K. IZBICKI
 ADP.

DATE
 12-23-68
 7-2-69

TITLE H-316 CONTROL LOGIC A	SIZE C	DWG NO. 70024506	REV. B
-----------------------------------	-----------	---------------------	-----------

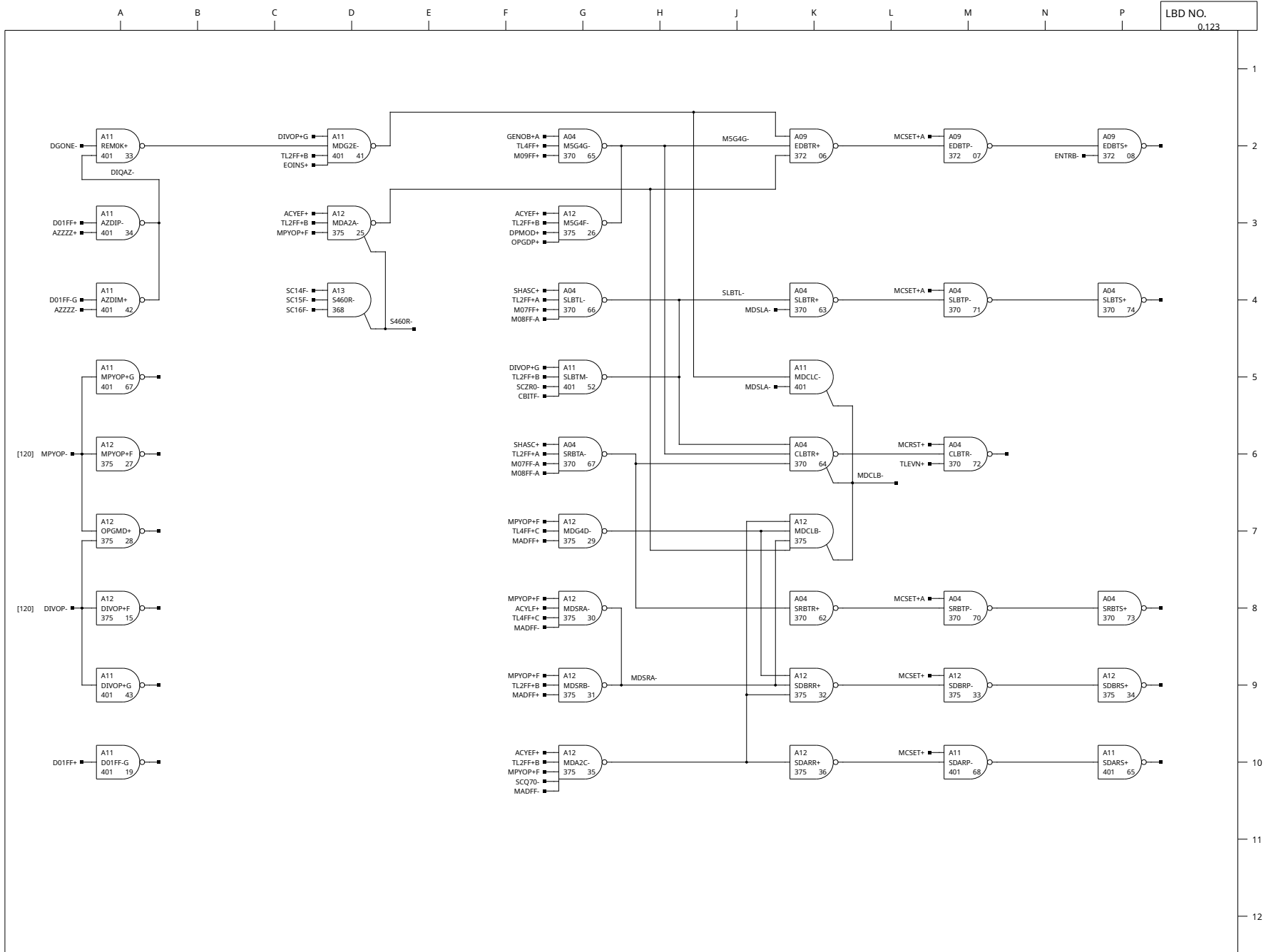

NOTES:
 △
 △
 △
 △

REV.	A
REVISIONS	#
CHK.	#
S. R. 54-3585	
ECO 7748 B	
EAT CHANGES SEE ECO 7748	

HONEYWELL
 INC.
 COMPUTER CONTROL DIVISION
 Old Connecticut Path, Framingham, Mass

DR. D. HAMEL	DATE
ENG. K. IZBICKI	12-26-1968
APP.	7-2-69

TITLE	H-316
	CONTROL LOGIC B
SIZE	DWG NO.
C	70024507
REV.	B

PROJECT NO. 55202

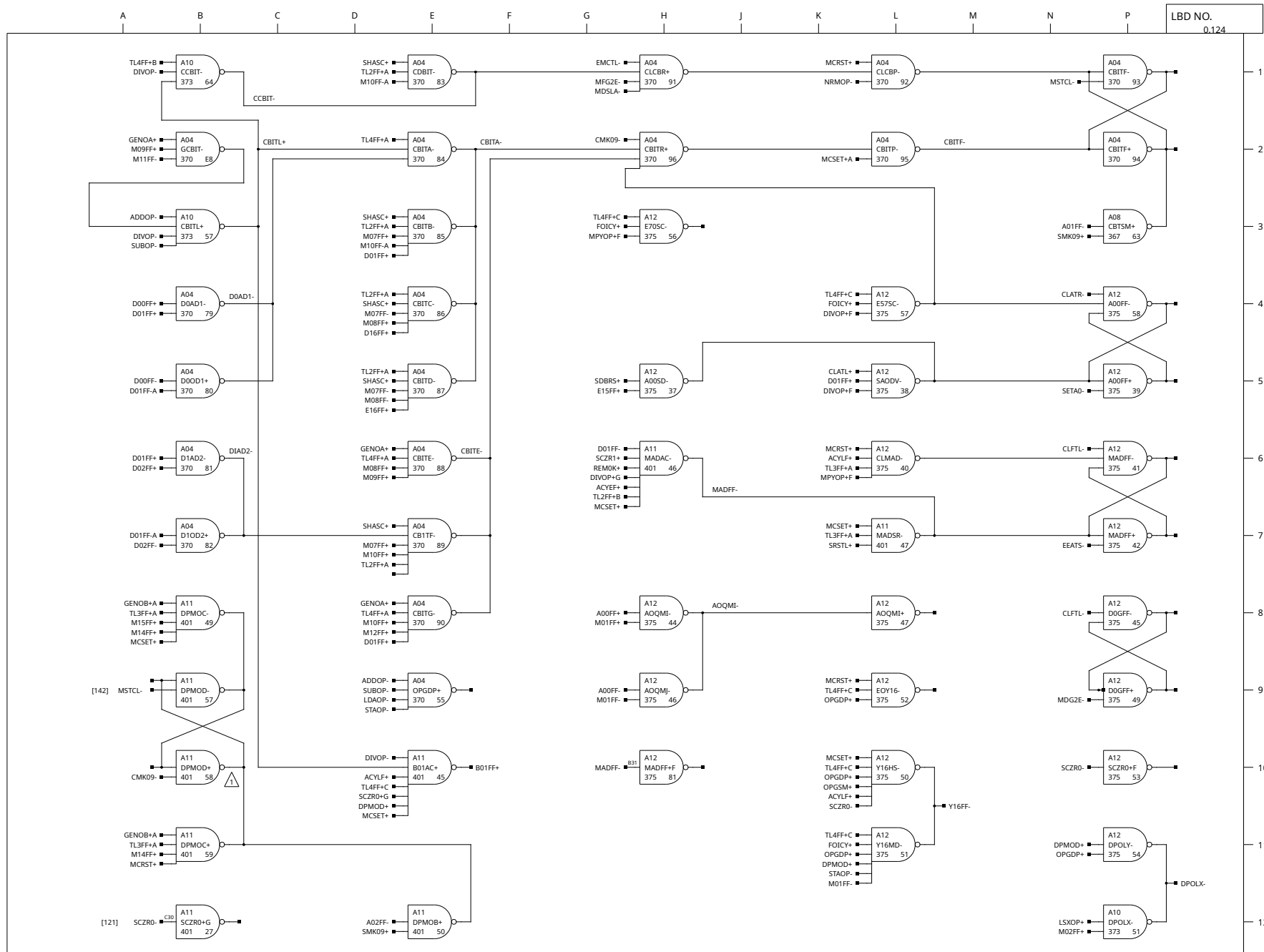

LBD NO.
0.124

- NOTES-
- △ THIS PT. IS GND WITH NO HSA OPTION
 - △
 - △
 - △
 - △

REV.	A
CHG.	
REVISIONS	
S. R. 54-3585	
ECO 7748	
EXT CHANGES	
SEE ECO 7748	

HONEYWELL
INC
COMPUTER CONTROL DIVISION
Old Connecticut Path, Framingham, Mass

DR. D. HAMEL	DATE
ENG. K. IZBICKI	1-13-1969
APP.	7-2-69

PROJECT NO. 55202

TITLE
H-316
CONTROL LOGIC C

SIZE	DWG NO.	REV.
C	70024508	B

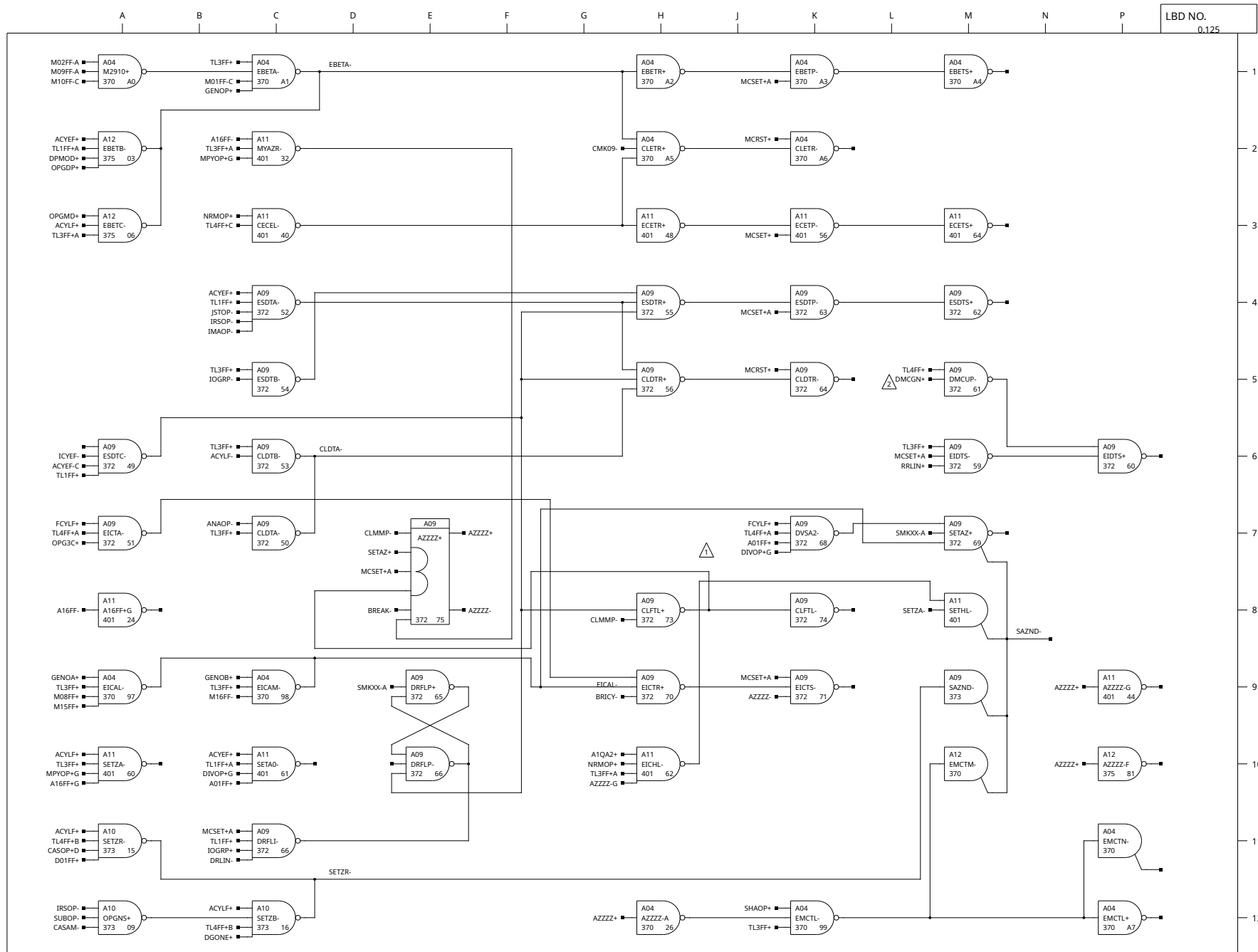

LBD NO.
0.125

NOTES-

- THIS PT. MUST BE GND WITH NO HSA OPTION.
- THIS PT. TIED TO GND.
-
-

CHK	REVISIONS	REV.
		A
		B
		C
		D
		E
		F
		G
		H
		J
		K
		L
		M
		N
		P

HONEYWELL
INC
COMPUTER CONTROL DIVISION
Old Connecticut Path, Framingham, Mass

DR. D. HAMEL	DATE
ENG. K. IZBICKI	12-27-1968
APP.	7-2-69

PROJECT NO. 55202

TITLE	H-316
	CONTROL LOGIC D/E
SIZE	DWG NO.
C	70024509
REV.	B

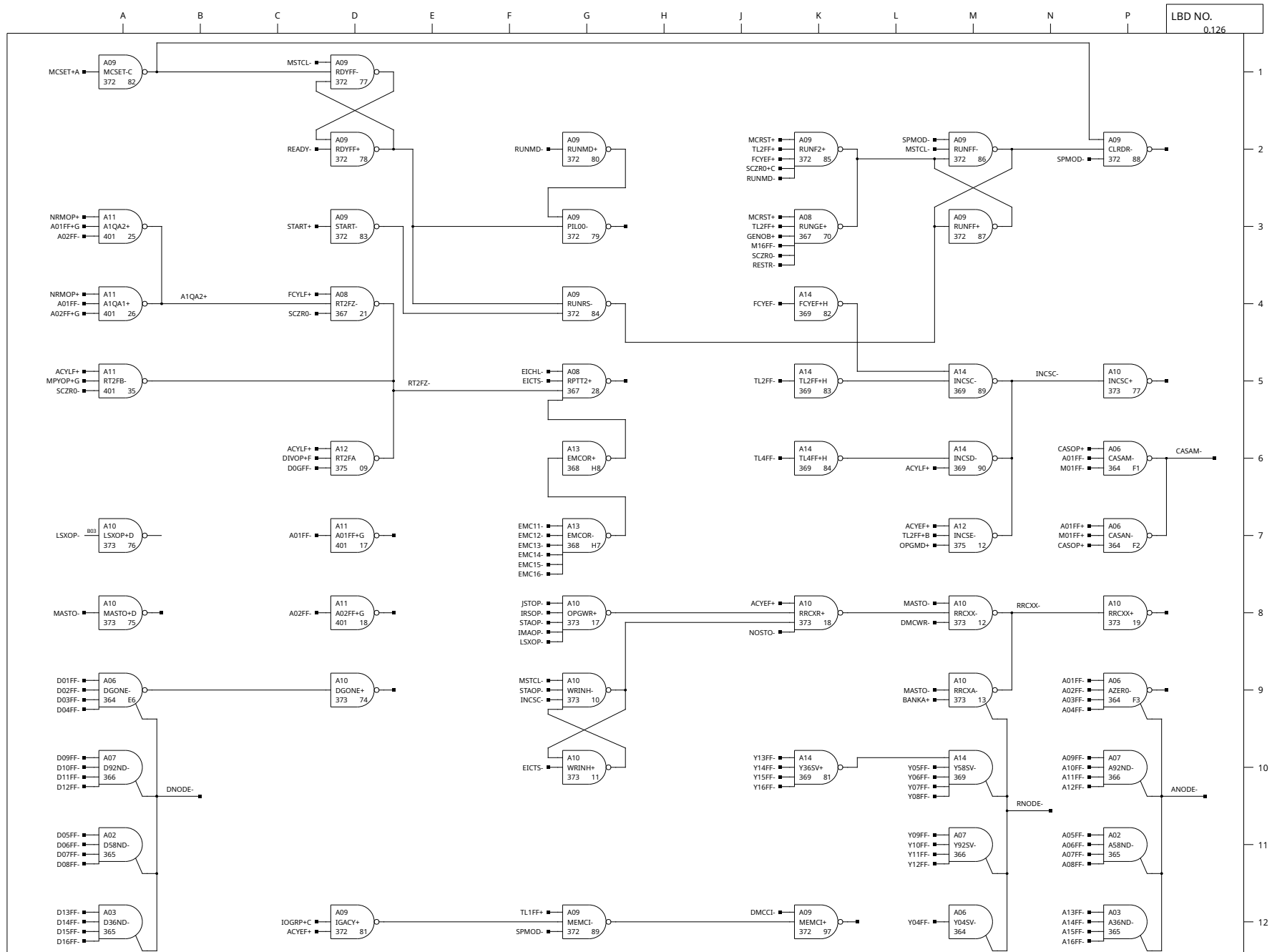

LBD NO.
0.126

NOTES-
△
△
△
△

REV.	DESCRIPTION	DATE
A	S. R. 54-3585	
B	ECO 7748	
C	ECO 7748	
D	ECO 7748	
E	ECO 7748	
F	ECO 7748	
G	ECO 7748	
H	ECO 7748	
I	ECO 7748	
J	ECO 7748	
K	ECO 7748	
L	ECO 7748	
M	ECO 7748	
N	ECO 7748	
O	ECO 7748	
P	ECO 7748	

HONEYWELL
INC
COMPUTER CONTROL DIVISION
Old Connecticut Path, Framingham, Mass

DR. D. HAMEL
ENG. K. IZBICKI
APP. _____

DATE
1-2-1969
7-2-69

TITLE
H-316
CONTROL LOGIC H

SIZE C DWG NO. 70024510 REV. B

PROJECT NO. 55202

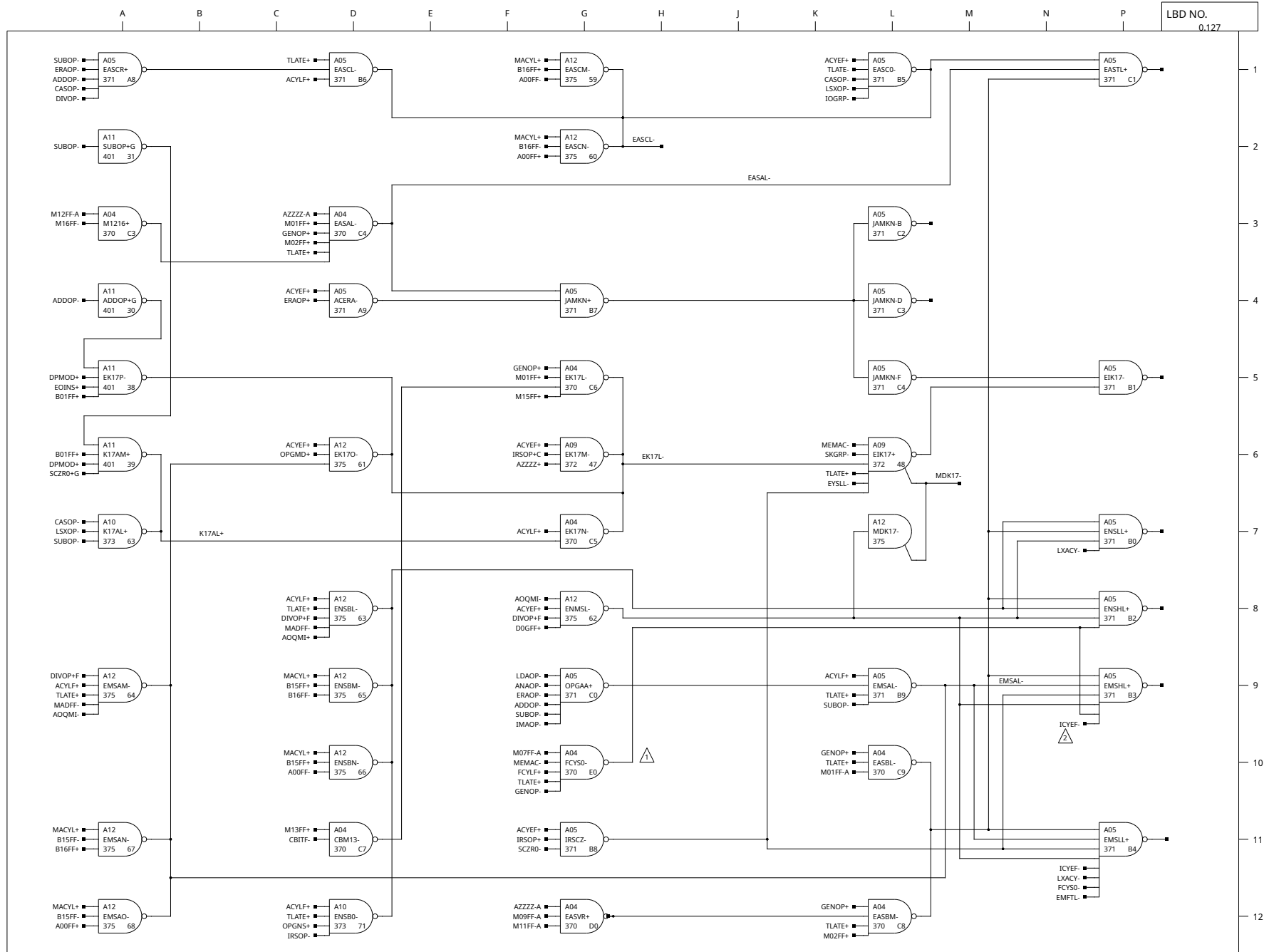

NOTES-
△ IF MEMORY LOCKOUT OPTION (316-08) IS INSTALLED DELETE FCYS- FROM A1AA0526
△ IF MEMORY LOCKOUT OPTION (316-08) IS INSTALLED SIGNAL ICYEF- ATA1AA0528 IS REPLACED WITH ICY51-
△
△

REV.	A
REVISIONS	1
1/1/69	
ECO 7748	
EAT CHANGES	
SEE ECO 1'A	
CHK.	
NO.	
S. R. 54-3585	

HONEYWELL
INC.
COMPUTER CONTROL DIVISION
Old Connecticut Path, Framingham, Mass

DR. D. HAMEL	DATE
ENG. K. IZBICKI	12-31-1968
APP.	7-9-69

TITLE	H-316
	CONTROL LOGIC
PROJECT NO.	55202
SIZE	C
DWG NO.	70024511
REV.	B

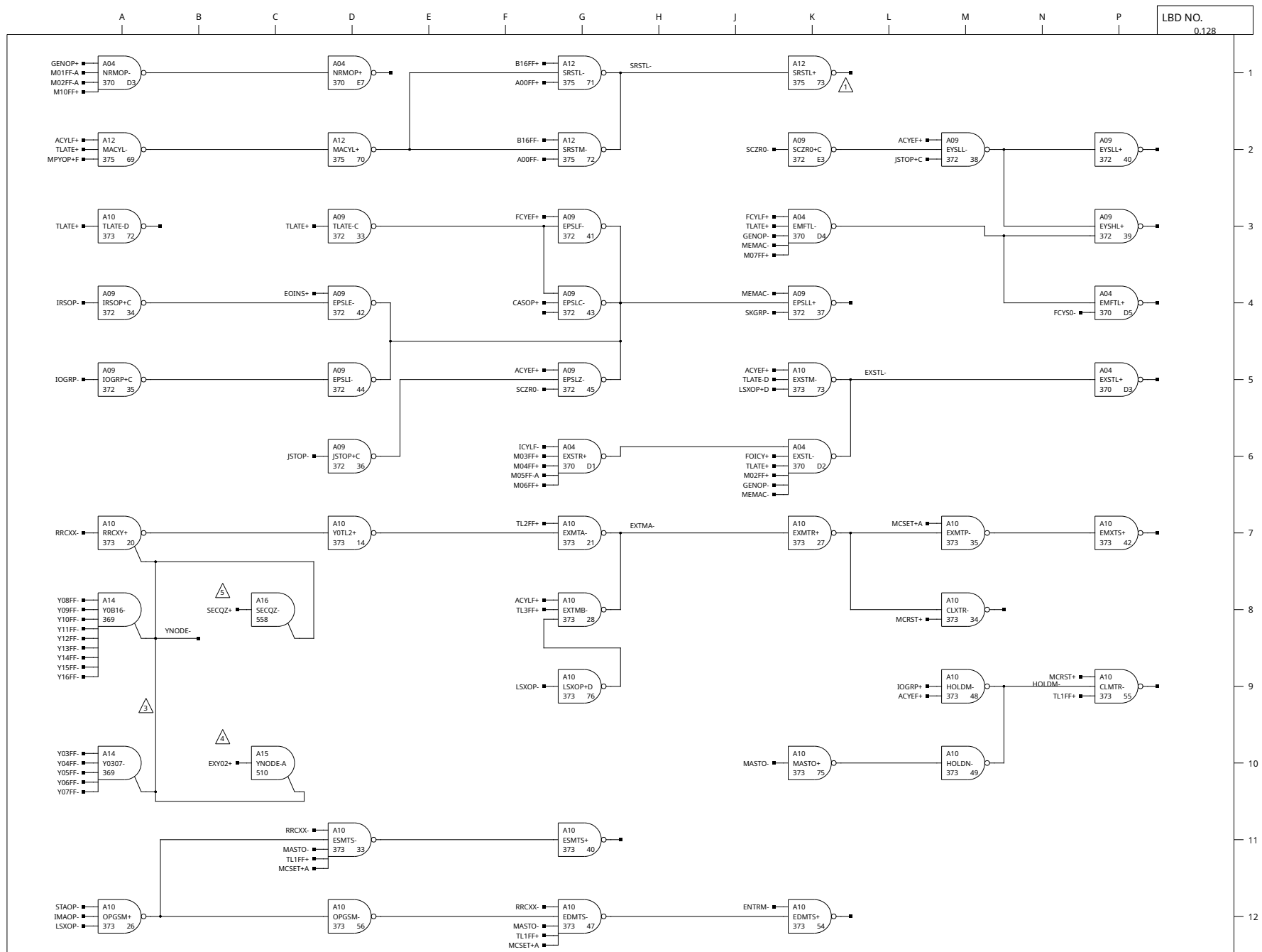

LBD NO.
0.128

NOTES-

- ⚠ THIS PT IS TIED TO GND WITH NO HSA OPTION
- ⚠ DELETE M02FF+ AND ADD M02D]+ WITH EXT ADD OPTION
- ⚠ DISCONNECT THIS WIRE IF MLO(316-08) IS INSTALLED
- ⚠ THIS GATE INCLUDED ONLY IF MLO (316-08) IS INSTALLED

REV.	DESCRIPTION
A	
B	
C	
D	
E	
F	
G	
H	
J	
K	
L	
M	
N	
P	

S. R. 54-3585
ECO 7748
EXT CHANGES SEE ECO 7748

HONEYWELL
INC
COMPUTER CONTROL DIVISION
Old Connecticut Path, Framingham, Mass

DR. D. HAMEL
ENG. K. IZBICKI
APP.

DATE
12-26-1968

TITLE H-316 CONTROL LOGIC MX	SIZE C	DWG NO. 70024512	REV. B
------------------------------------	-----------	---------------------	-----------

PROJECT NO. 55202

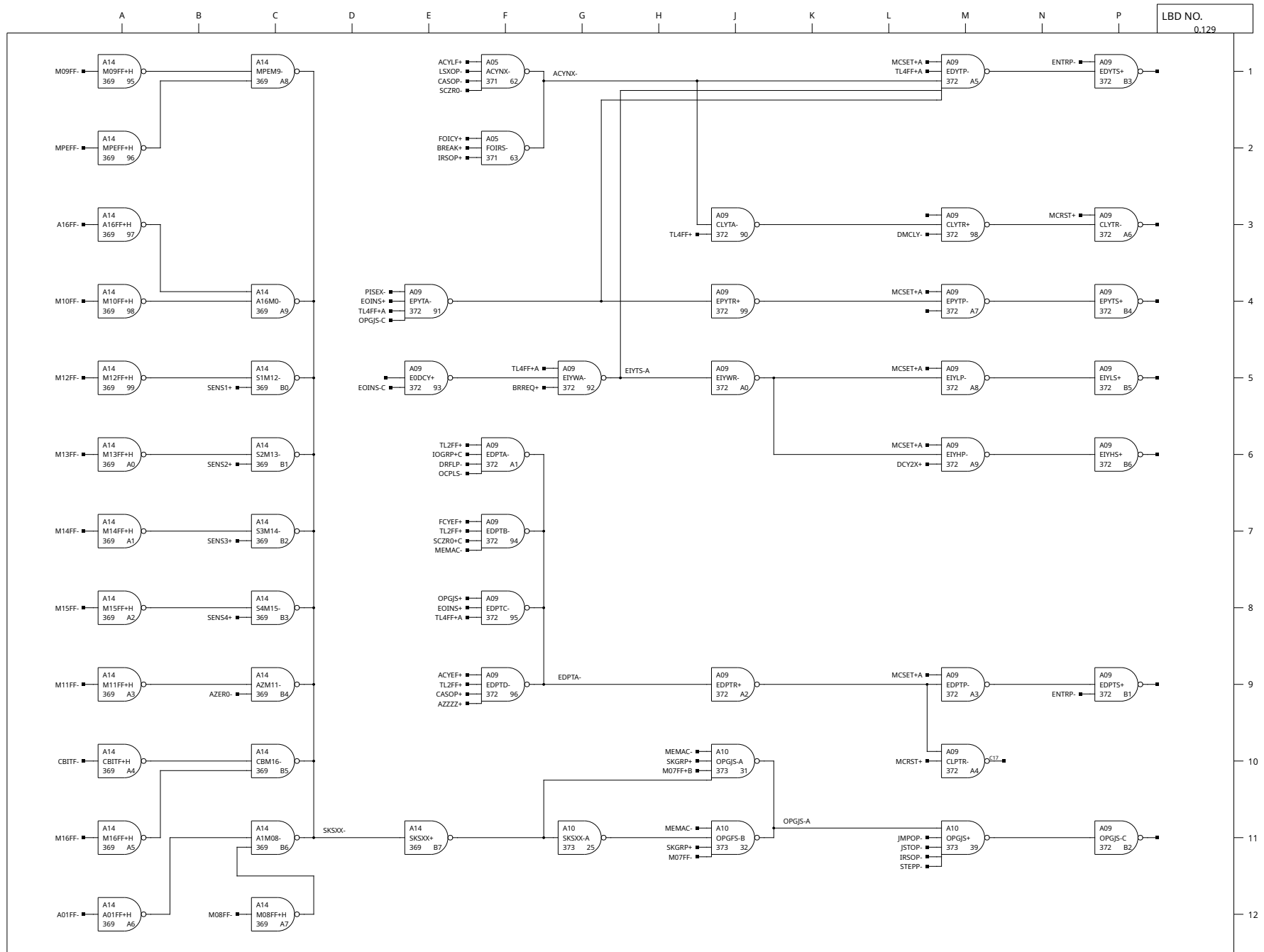

LBD NO.
0,129

NOTES:
 ▲
 ▲
 ▲
 ▲

REV.	A
CHG.	REV. S. R. 54-3585
REV.	ECO 7748
REV.	EXT CHANGES SEE ECO 7748

HONEYWELL
 INC.
 COMPUTER CONTROL DIVISION
 Old Connecticut Path, Framingham, Mass

DR. D. HAMEL DATE
 ENG. K. IZBICKI 1-2-1969
 ADP. 7-2-69

PROJECT NO. 55202

TITLE
H-316
CONTROL LOGIC PY

SIZE C DWG NO. 70024513 REV. B

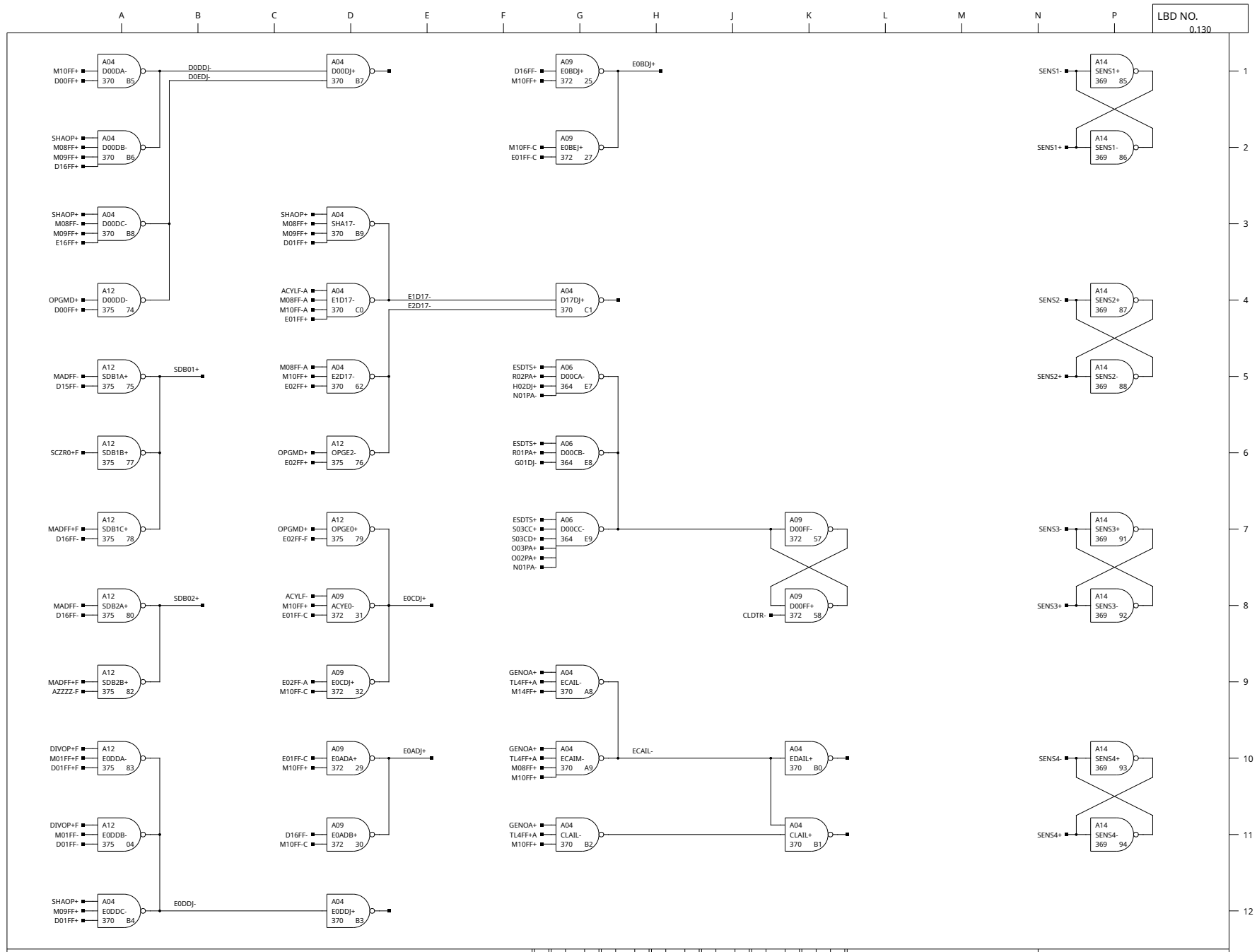

LBD NO.
0.130

NOTES-

- △
- △
- △
- △

REV.	DESCRIPTION	DATE
A		
B		
C		
D		
E		
F		
G		
H		
J		
K		
L		
M		
N		
P		

HONEYWELL
INC
COMPUTER CONTROL DIVISION
Old Connecticut Path, Framingham, Mass

DR. D. HAMEL
ENG. K. IZBICKI
APP.

DATE
1-4-1969
7-2-69

TITLE H-316 CONTROL LOGIC PY	SIZE C	DWG NO. 70024514	REV. B
------------------------------------	-----------	---------------------	-----------

PROJECT NO. 55202

A B C D E F G H J K L M N P

LBD NO.
0.132

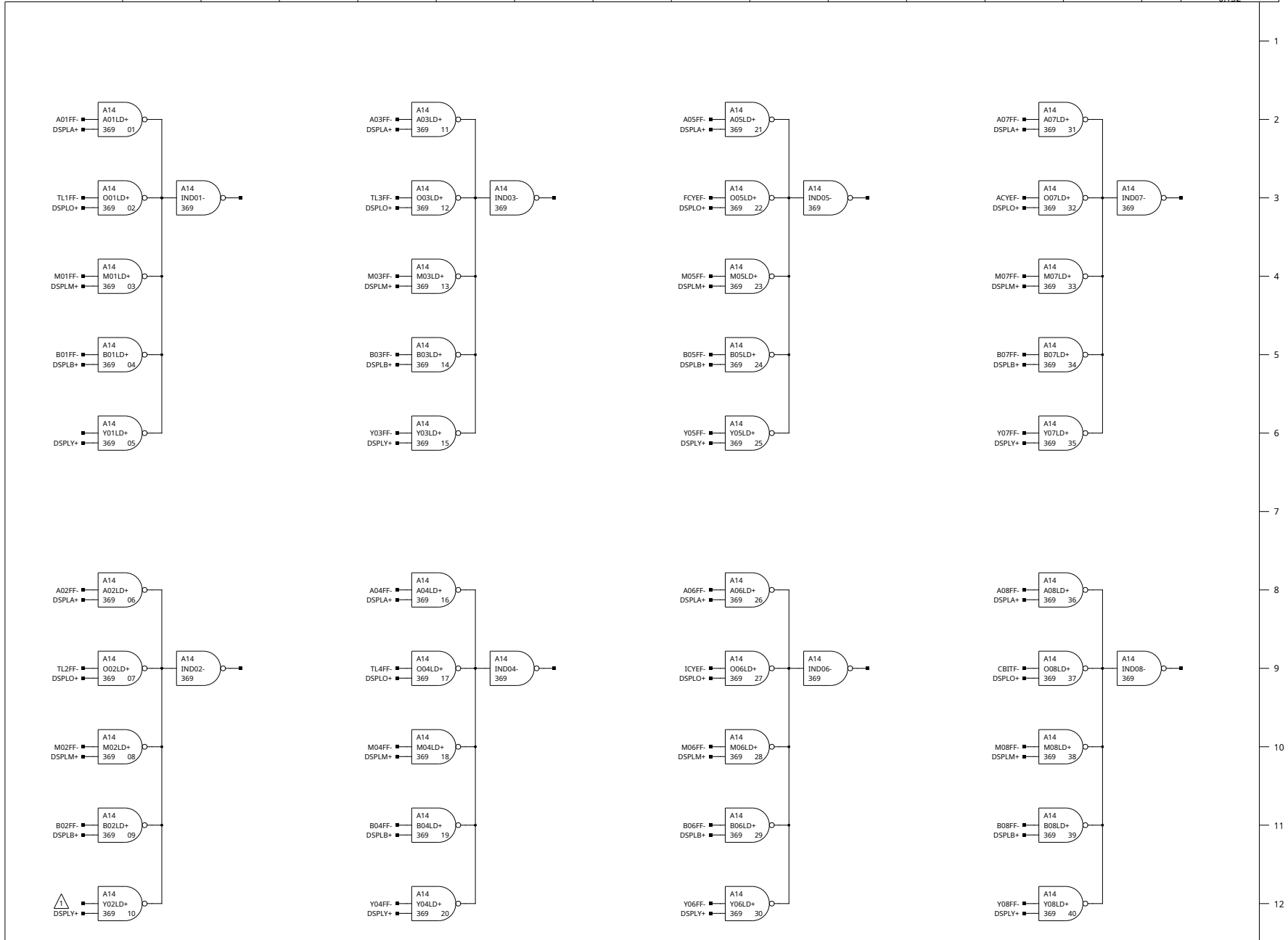

- NOTES-
- △ ADD Y02FF- WITH EXT ADD OPTION
 - △
 - △
 - △

REV.	A
CHK.	
REVISIONS	
S. R.	54-3585
ECO 7748	1/19/76
EXT CHANGES	SEE ECO 7748

HONEYWELL
INC
COMPUTER CONTROL DIVISION
Old Connecticut Path, Framingham, Mass

DR. D. HAMEL	DATE
ENG. K. IZBICKI	1-7-1969
APP.	

PROJECT NO. 55202

TITLE	H-316
	LAMP DRIVER 1-8
SIZE	DWG NO.
C	70024515
REV.	B

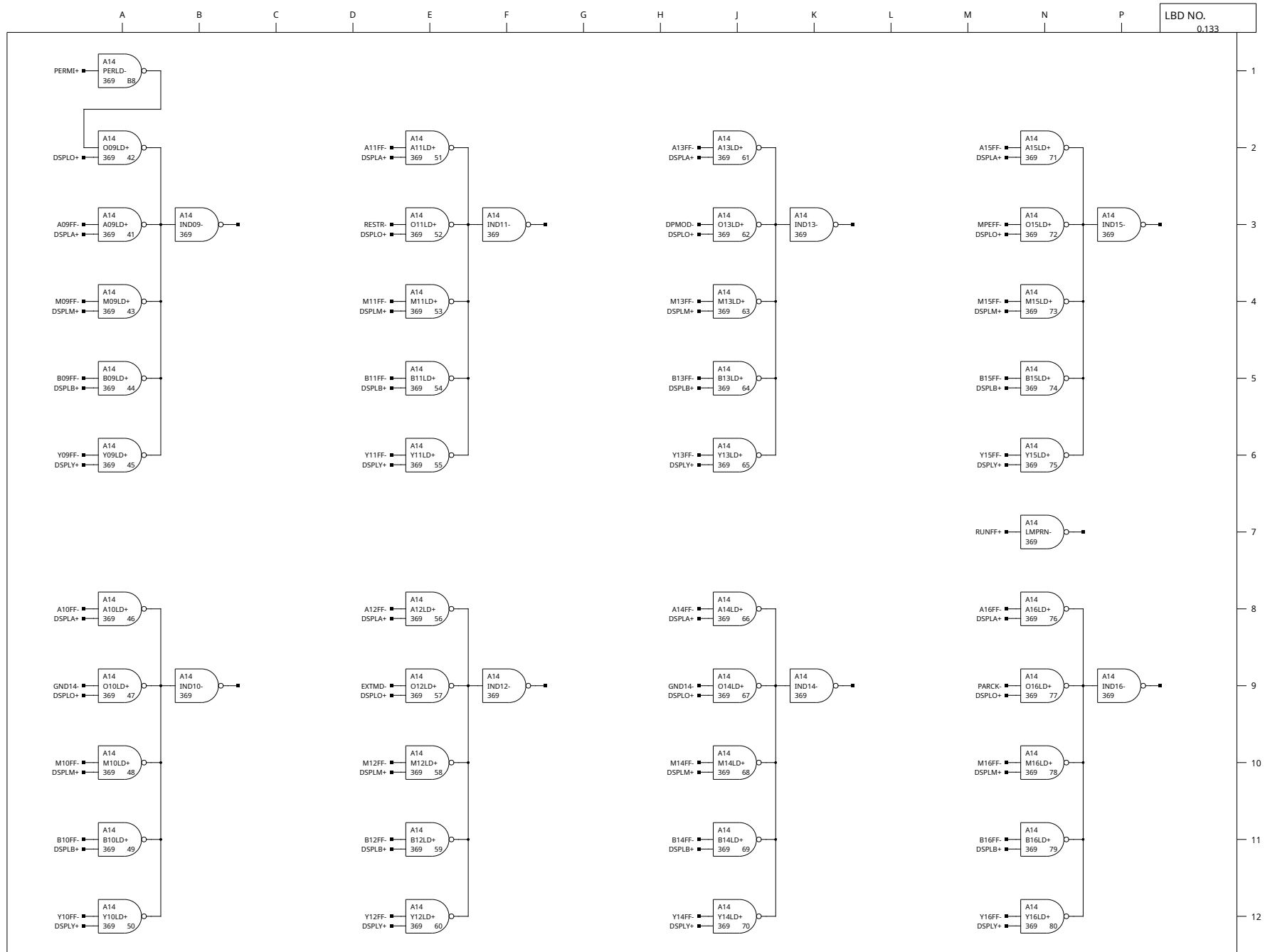

LBD NO.
0.133

NOTES:
△
△
△
△

REV.	A
CHG.	REV.
NO.	NO.
S. R. 54-3585	
ECO 7748	1/19/70
EXT CHANGES SEE ECO 7748	

HONEYWELL
INC
COMPUTER CONTROL DIVISION
Old Connecticut Path, Framingham, Mass

DR. D. HAMEL	DATE
ENG. K. IZBICKI	1-4-1969
APP.	7-2-69

PROJECT NO. 55202

TITLE
H-316
LAMP DRIVER 9-16

SIZE C DWG NO. 70024516 REV. B

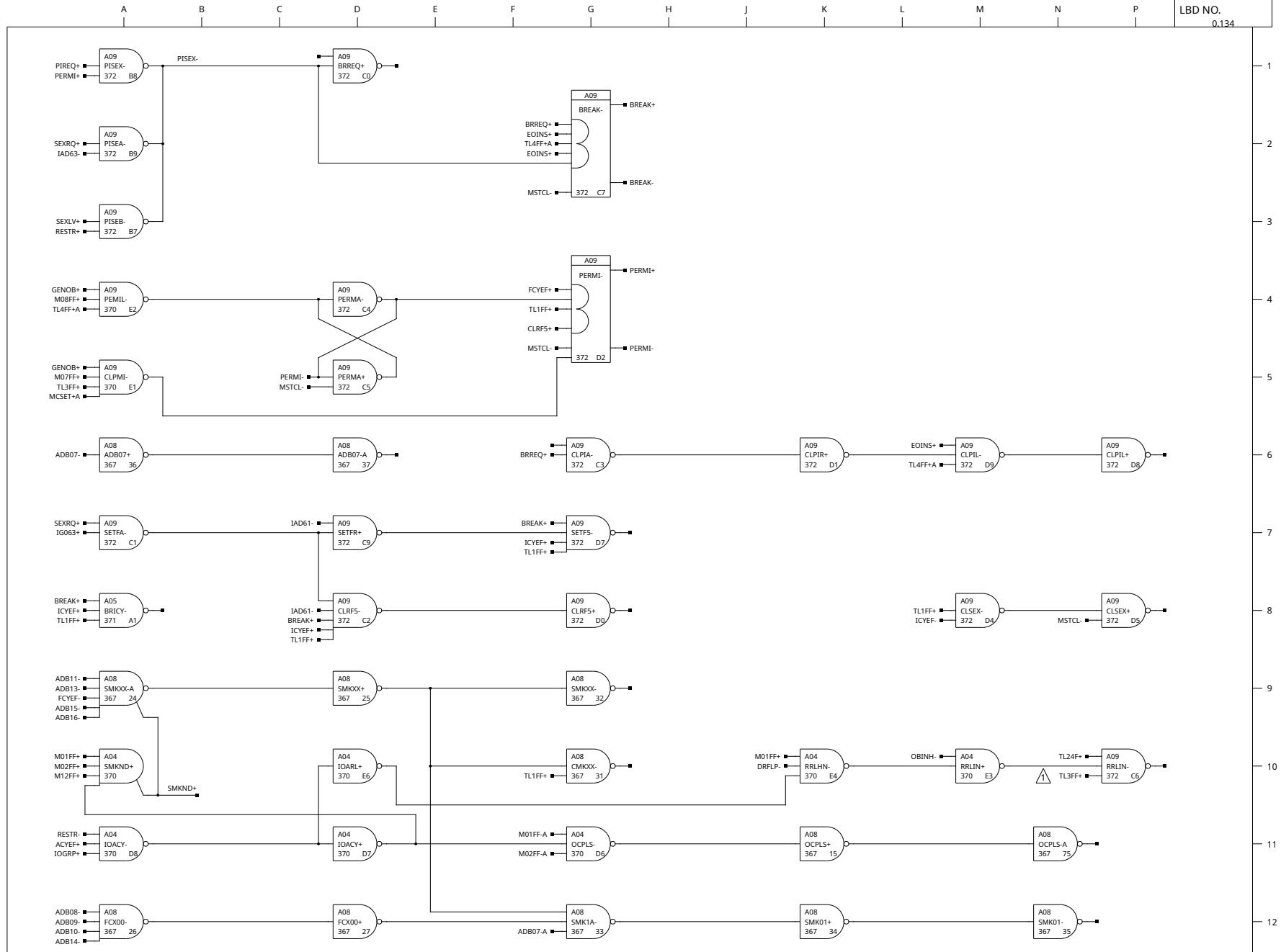

- NOTES-
- ⚠ WITH DMC OPTION REPLACE TL3FF+ WITH DMRL+
 - ⚠
 - ⚠
 - ⚠

REV.	REVISIONS
A	
B	ECO 7277A
C	EXT CHANGES SEE ECO 1072/109
D	ECO 7748
E	EXT CHANGES SEE ECO T.A. 1/19/70

HONEYWELL
INC
COMPUTER CONTROL DIVISION
Old Connecticut Path, Framingham, Mass

DR. D. HAMEL	DATE
ENG. K. IZBICKI	1-3-1969
APP.	7-2-69

TITLE	H-316
	CONTROL LOGIC I/O
SIZE	DWG NO.
C	70024517

PROJECT NO. 55202

REV. B

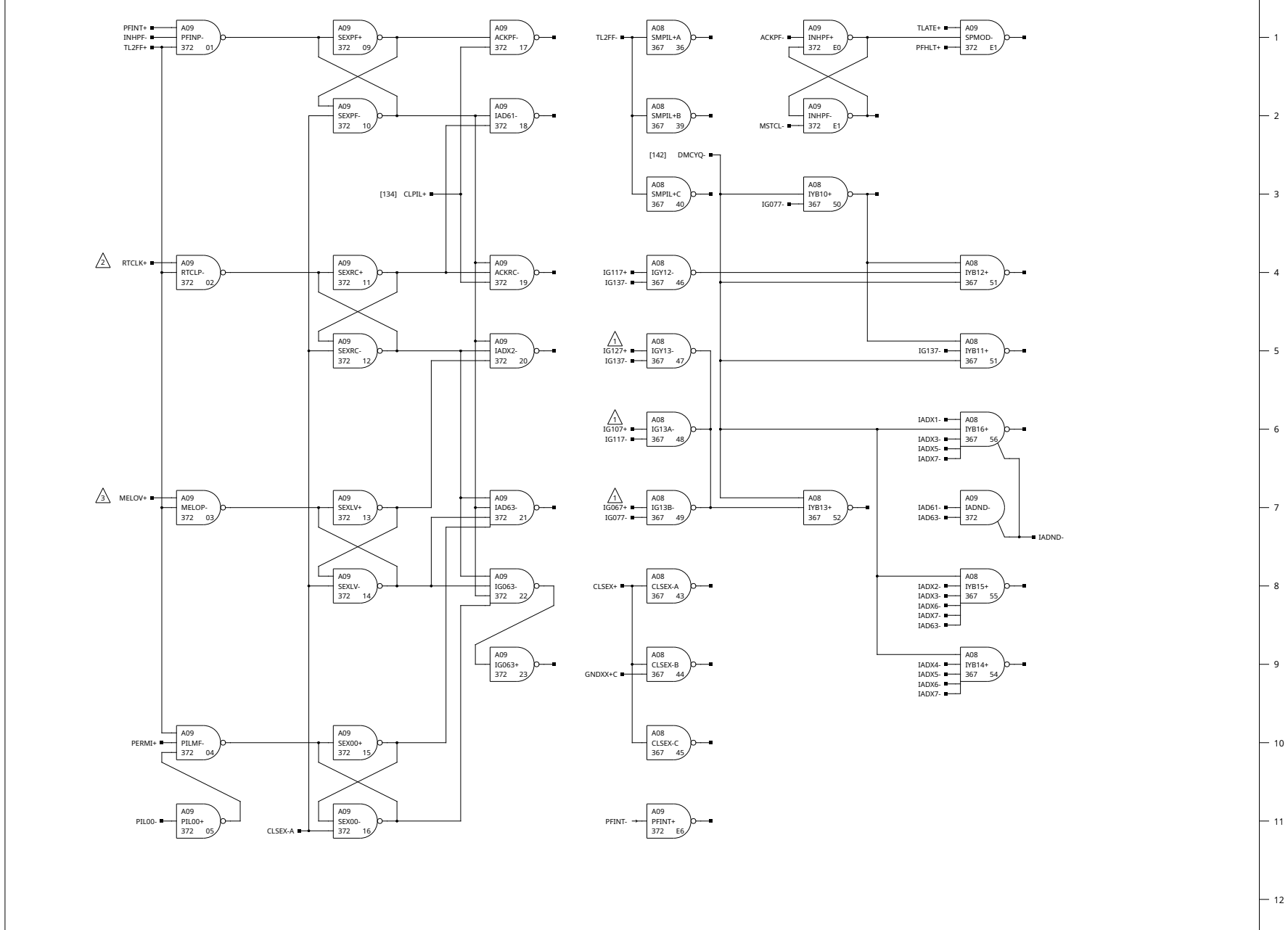

- NOTES-**
- △ THIS PT IS GND WITH NO PI OPTION
 - △ THIS PT IS GND WITH NO RTC OPTION
 - △ THIS PT IS GND WITH NO M.L. OPTION

CHK	REVISIONS	REV
#	#	A
S. R. 54-3585		
ECO 7748		1/19/76
EAT CHANGES SEE ECO 77A		

HONEYWELL
INC
COMPUTER CONTROL DIVISION
Old Connecticut Path, Framingham, Mass

DR. J D GILMARTIN DATE
 ENG. K IZBICKI 1-9-1969
 ADP. 7-2-69

PROJECT NO. 55202

SIZE	DWG NO.	REV
C	70024518	B

TITLE
H-316
INTERRUPT ADDRESS ENCODING

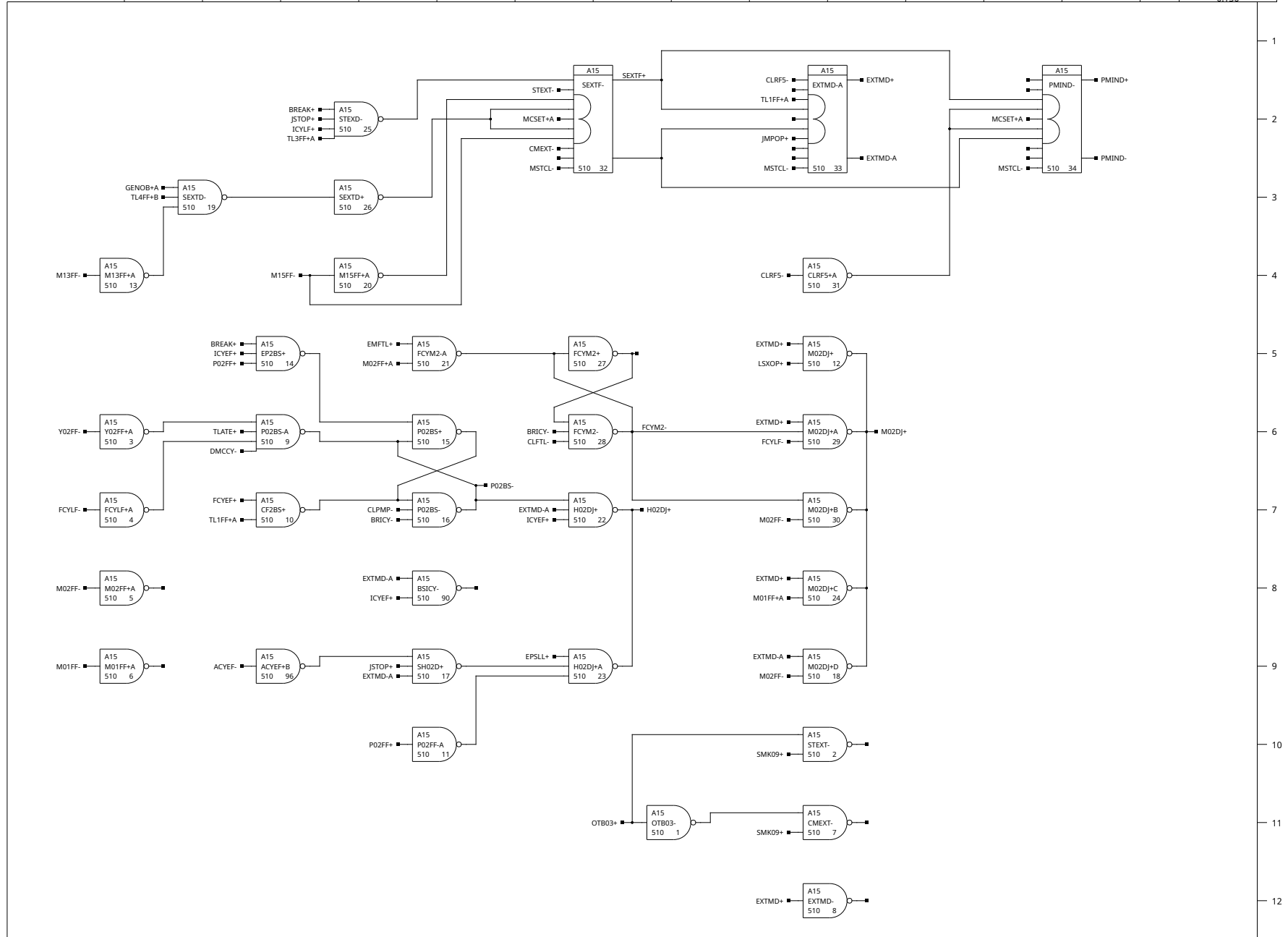

NOTES-

- △
- △
- △
- △

CHK	REVISIONS	REV
		A

S. R. 54-3915	

HONEYWELL
 INC
 COMPUTER CONTROL DIVISION
 Old Connecticut Path, Framingham, Mass

DR. D. HAMEL	DATE
ENG. R. ALBRIGHT	5-16-1969
APP.	

PROJECT NO. 53217

TITLE	H-316
	MEMORY EXPANSION
	CONTROL LOGIC
SIZE	DWG NO.
C	70025829
REV	A

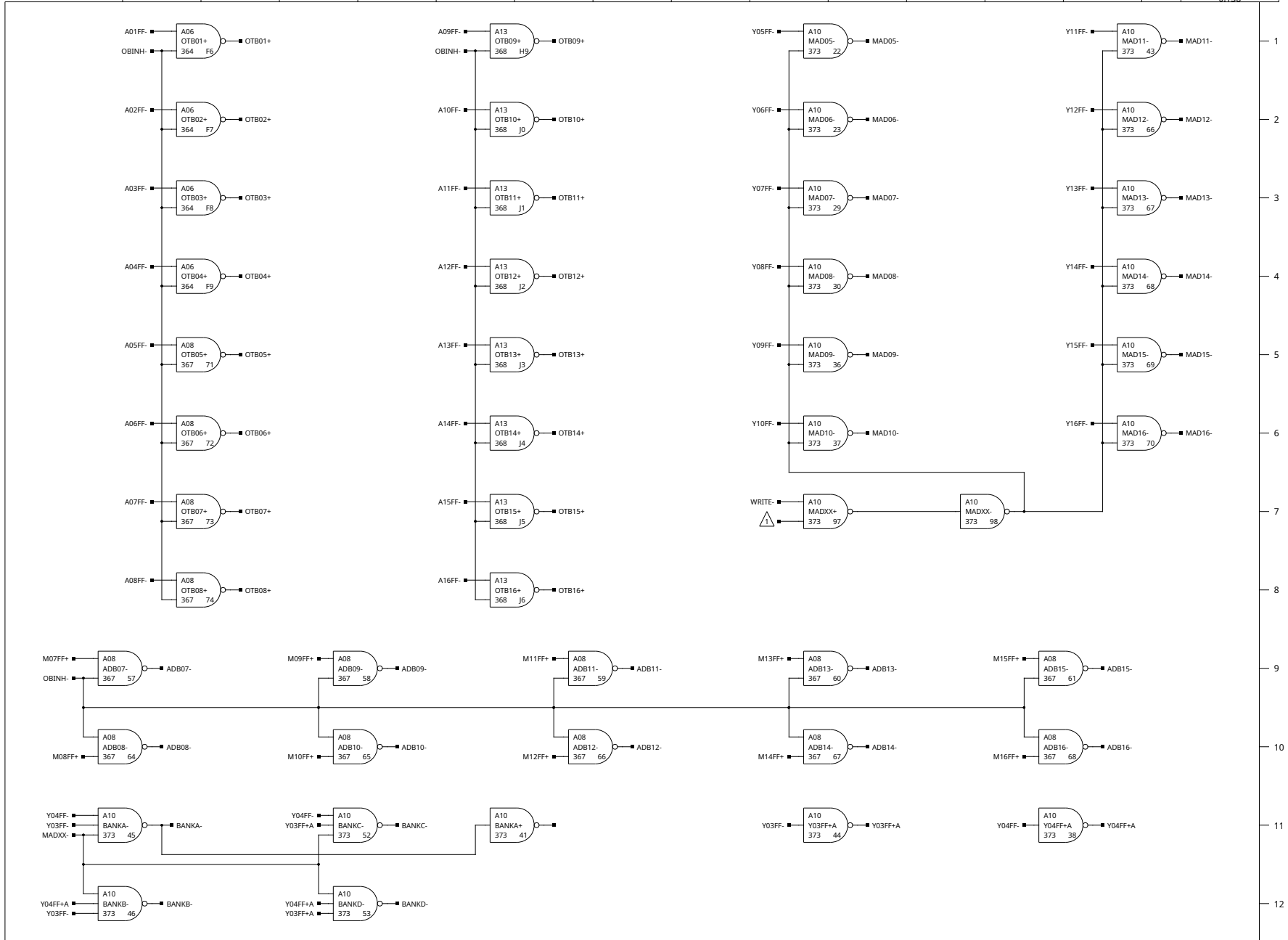

- NOTES-
- △ ADD Y02FF- WITH EXT. ADD OPTION
 - △
 - △
 - △

REV.	A
CHG.	REV.
NO.	NO.
S. R. 54-3585	
ECO 7748	1/19/70
EXT CHANGES SEE ECO 7748	

HONEYWELL
 INC
 COMPUTER CONTROL DIVISION
 Old Connecticut Path, Framingham, Mass

DR. D. HAMEL	DATE
ENG. K. IZBICKI	1-13-1969
APP.	7-2-69

PROJECT NO. 55202

TITLE	H-316
	OUTPUT BUSES
SIZE	DWG NO.
C	70024519
REV.	B

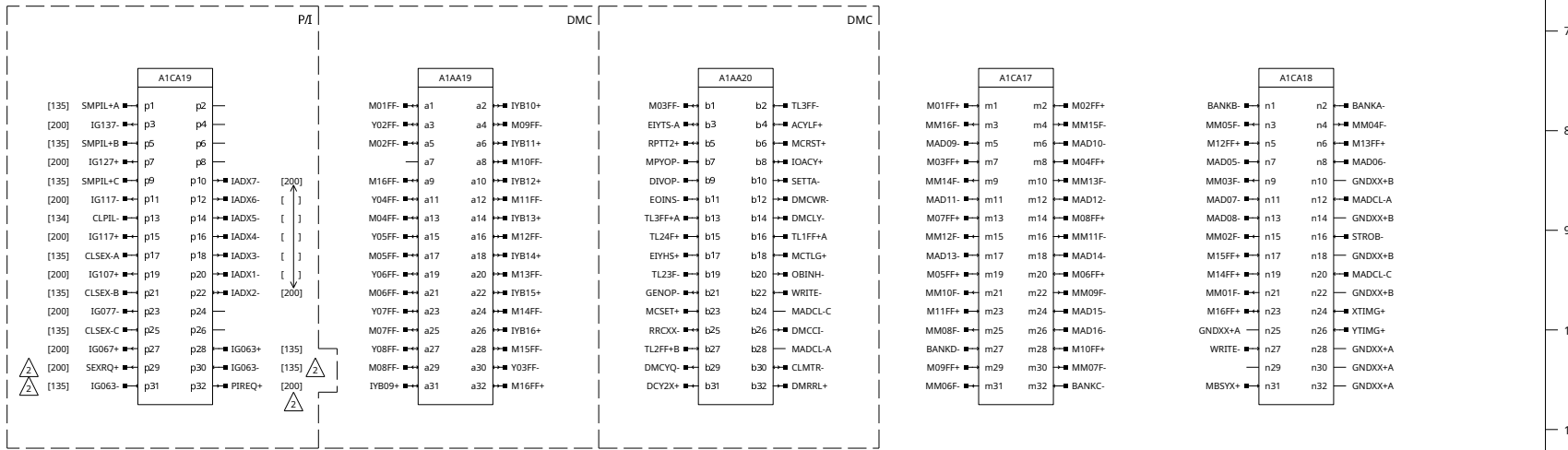
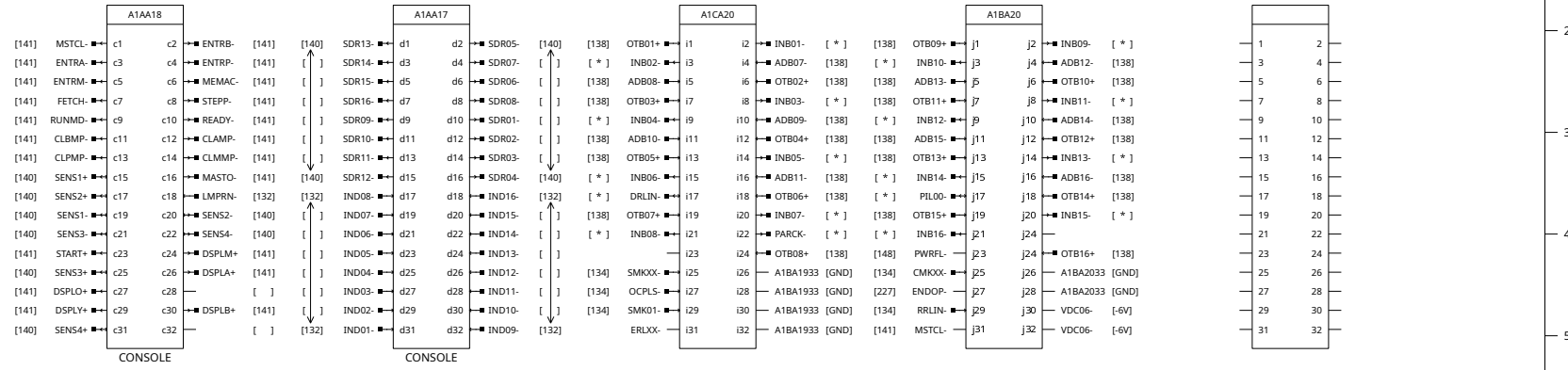

NOTES:
 △ * THESE SIGNALS ARRIVE BY BUS FROM I/O OPTIONS, DEPENDING ON SYSTEM CONFIGURATION
 △ WITH NO PI TIE SEXRQ+ AND PIREQ+ TO IG063-
 △
 △

REV	A
REV	1
REV	2
REV	3
REV	4
REV	5
REV	6
REV	7
REV	8
REV	9
REV	10
REV	11
REV	12

HONEYWELL
 INC
 COMPUTER CONTROL DIVISION
 Old Connecticut Path, Framingham, Mass

DR. D. HAMEL DATE
 ENG. K. IZBICKI 1-20-1969
 ADP. 7-2-69

PROJECT NO. 55202

TITLE	H-316
TITLE	CONSOLE AND I/O CONNECTORS
SIZE	DWG NO.
C	70024523
REV	B

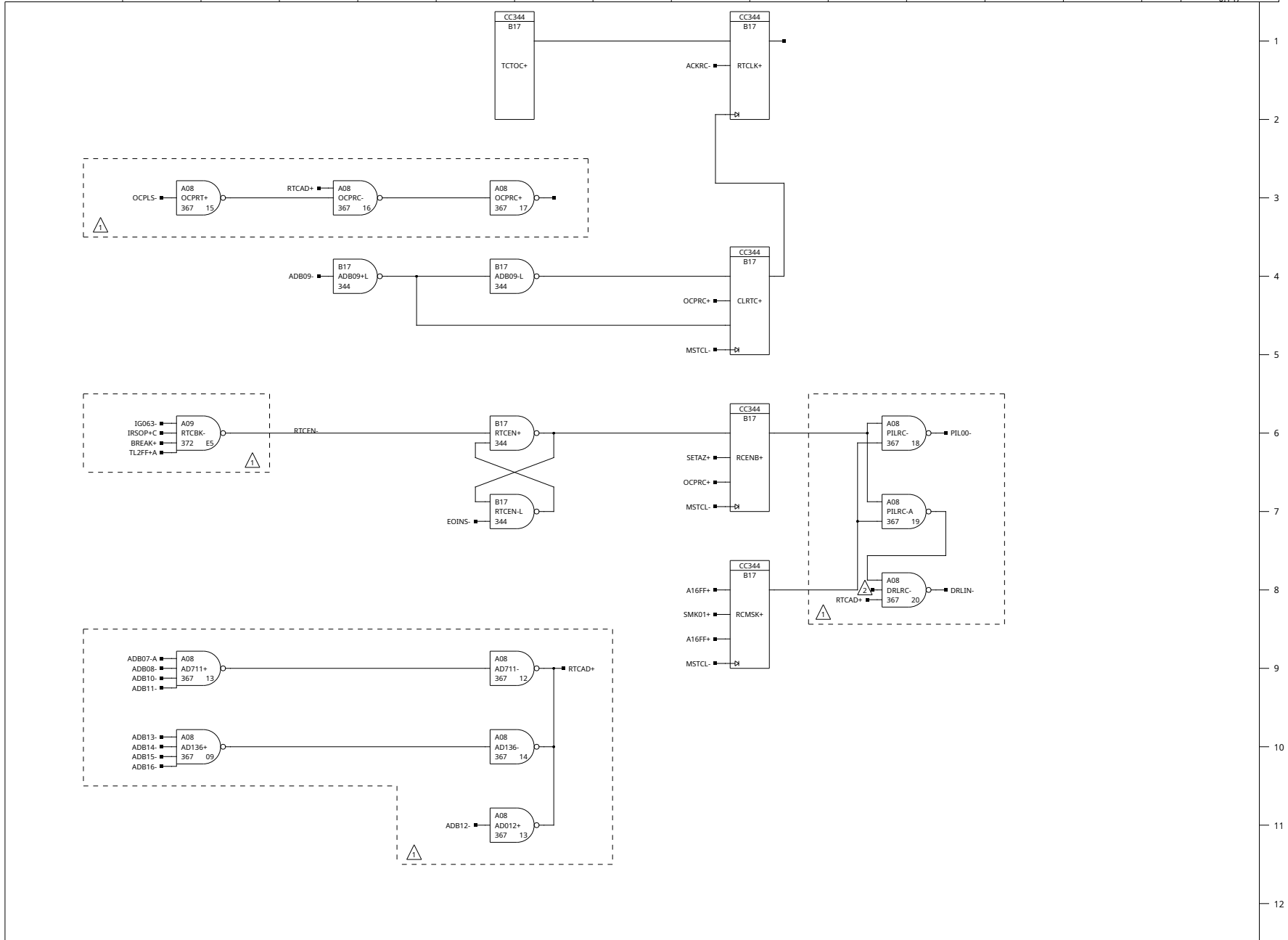

- NOTES-**
- ⚠ THESE CIRCUITS ALSO SHOWN ON L.B.D. 0.119
 - ⚠ REMOVE GND WHEN USING RTC
 - ⚠
 - ⚠

REV.	A
REVISIONS	—
DATE	5/19/70
DESIGNED BY	ECO7748
CHECKED BY	
APPROVED BY	
PROJECT NO.	55202

HONEYWELL
INC
COMPUTER CONTROL DIVISION
Old Connecticut Path, Framingham, Mass

DR. D. HAMEL	DATE
ENG. K. IZBICKI	2-27-69
APP.	4/10/69

TITLE	H-316-12
	REAL TIME CLOCK
SIZE	DWG NO.
C	70024524
REV.	B

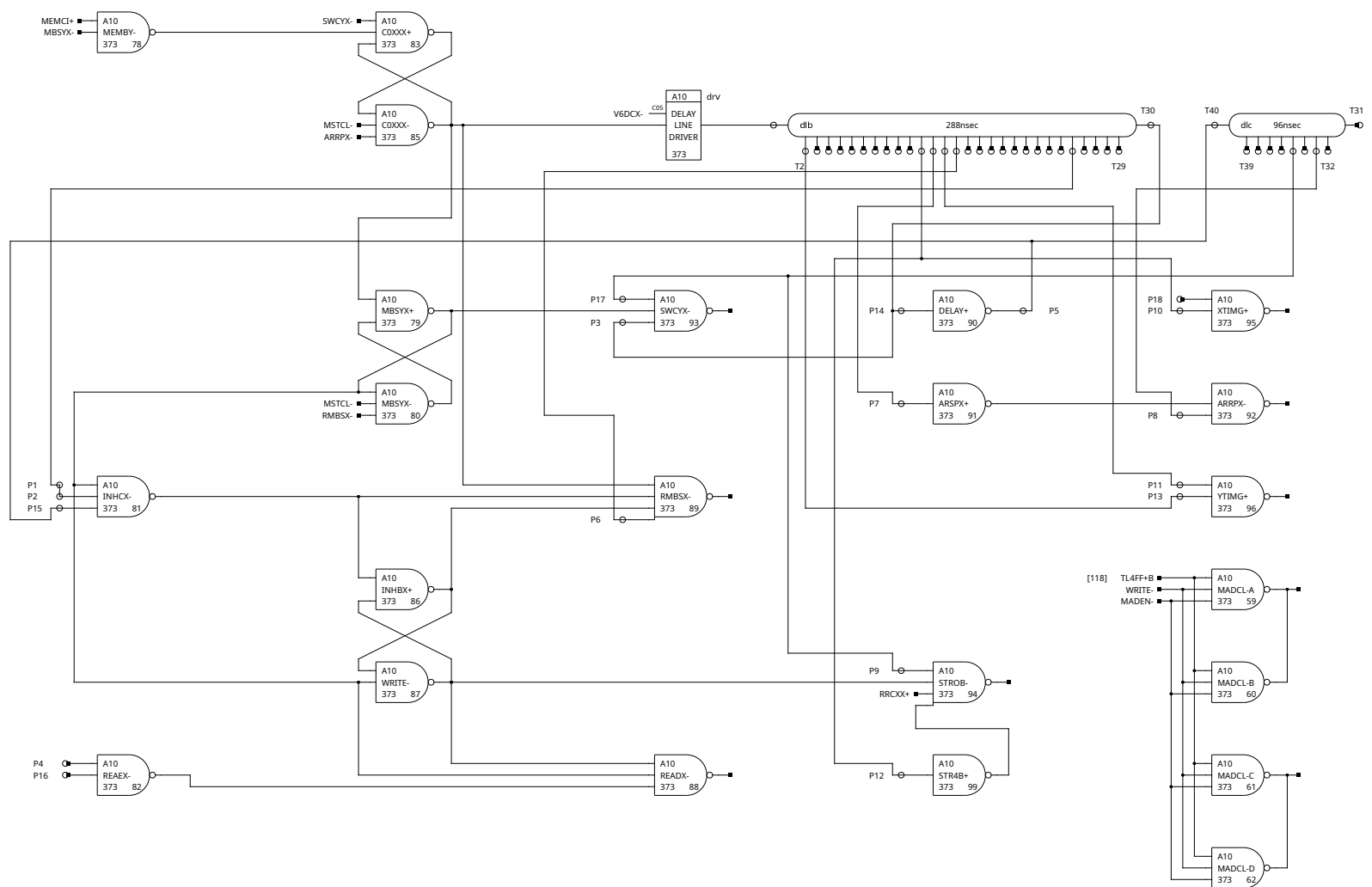

NOTES-
 ▲
 ▲
 ▲
 ▲

REV.	A
CHG.	REV. #
NO.	S. R. 54-3585
ECO 7748	BY CHG. SELECT. JD

HONEYWELL
 INC
 COMPUTER CONTROL DIVISION
 Old Connecticut Path, Framingham, Mass

DR. D. HAMEL	DATE
ENG. K. IZBICKI	1-21-1969
APP.	7-2-69

TITLE	H-316
	TIMING & CONTROL
SIZE	DWG NO.
C	70024529
REV.	B

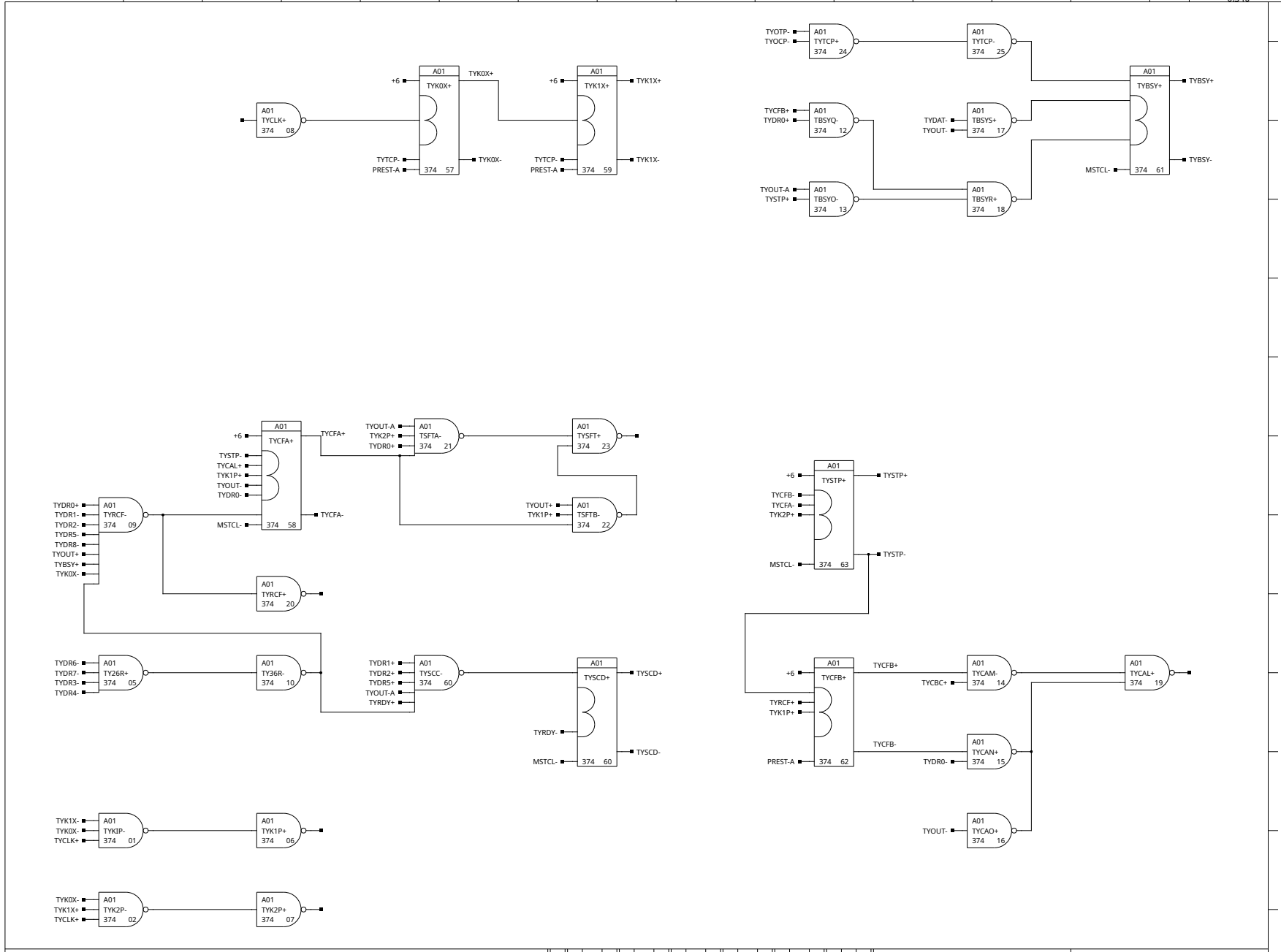

NOTES-

- △
- △
- △
- △

CHK	REVISIONS	REV
		A
	S. R. 54-3585	

HONEYWELL
INC
COMPUTER CONTROL DIVISION
Old Connecticut Path, Framingham, Mass

DR. D. HAMEL	DATE
ENG. K. IZBIKLI	1-9-1969
APP.	4-10-69

PROJECT NO. 53202

TITLE	H-316
ASR 33/35	
CONTROL	
SIZE	DWG NO.
C	70024526
REV.	A

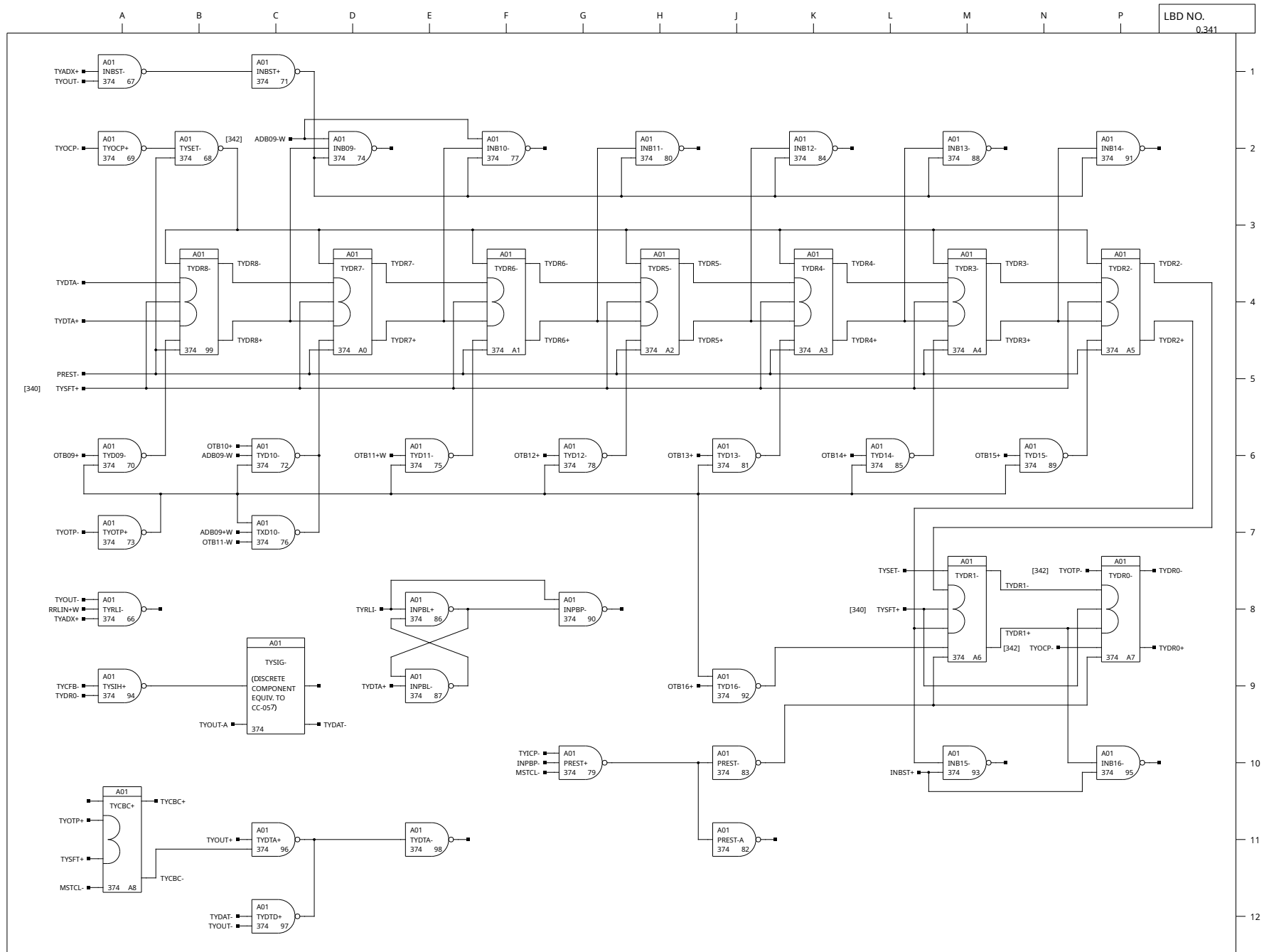

LBD NO.
0.341

NOTES:
 ▲
 ▲
 ▲
 ▲

REV.	DESCRIPTION	DATE
A		
B	ECO 7748	11/19/76
	EXT CHANGES SEE ECO 7748	

HONEYWELL
 INC
 COMPUTER CONTROL DIVISION
 Old Connecticut Path, Framingham, Mass

TITLE
 H-316 -56
 BUFFER REGISTER
 ASR 33/35
 DATE
 1-8-1969
 4-10-69
 DWG NO.
 70024527
 REV.
 B

DR. D. HAMEL
 ENG. K. IZBICKI
 ADP.
 PROJECT NO. 53202

DATE
 1-8-1969
 4-10-69
 DWG NO.
 70024527
 REV.
 B

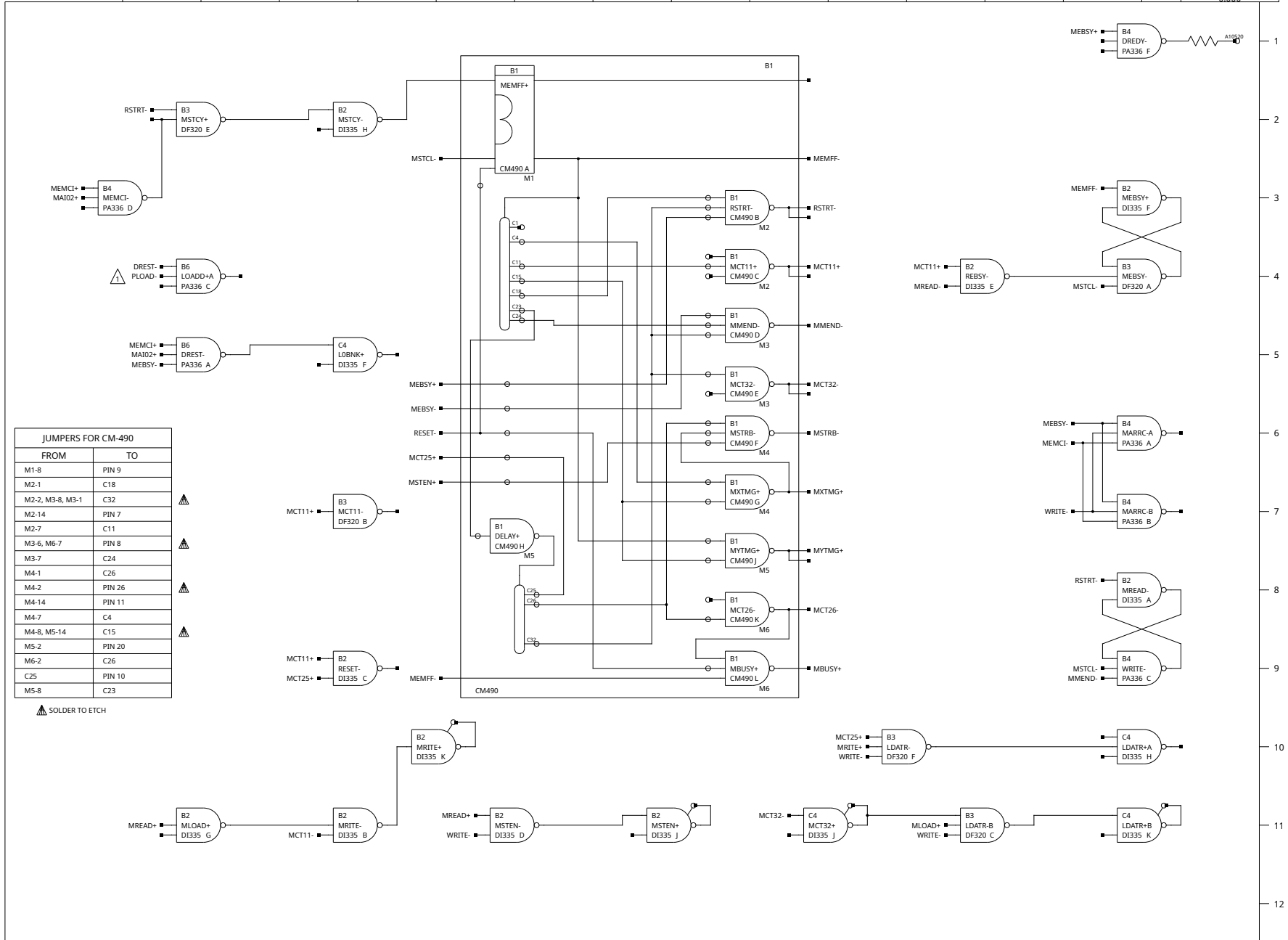

JUMPERS FOR CM-490

FROM	TO
M1-8	PIN 9
M2-1	C18
M2-2, M3-8, M3-1	C32
M2-14	PIN 7
M2-7	C11
M3-6, M6-7	PIN 8
M3-7	C24
M4-1	C26
M4-2	PIN 26
M4-14	PIN 11
M4-7	C4
M4-8, M5-14	C15
M5-2	PIN 20
M6-2	C26
C25	PIN 10
M5-8	C23

▲ SOLDER TO ETCH

NOTES-

- ▲ SOURCE FOR SIGNAL PLOAD- IS MEMORY PARITY WHEN INSTALLED
- ▲
- ▲
- ▲

CHK	REV	REVISIONS
	A	
	B	ECO 8536
	C	EXT. CHGS SEE ECO 77220
	D	ECO 9490
	E	ECO 20887
	F	CHGD PER ECO 1222772
	G	SEE ECO 72359

S. R. 54-3915

HONEYWELL
 INC
 COMPUTER CONTROL DIVISION
 Old Connecticut Path, Framingham, Mass

DR. D. HAMEL	DATE
ENG. R. ALBRIGHT	5/15/69
APP.	9/12/69

PROJECT NO. 53217

TITLE
 H-316
 MEMORY EXPANSION
 MEMORY TIMING & CONTROL

SIZE	DWG NO.	REV.
C	70025825	E

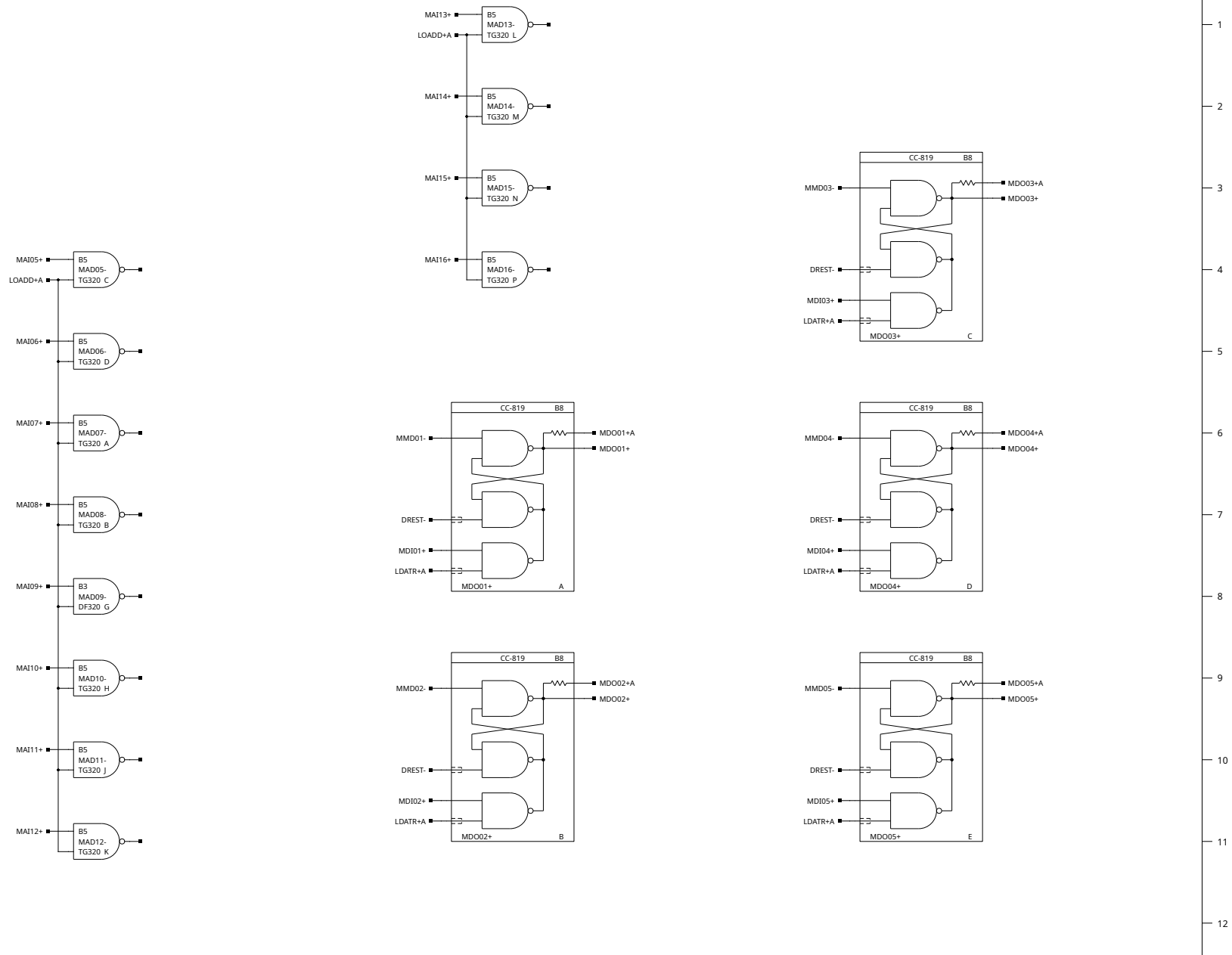

NOTES:
 ▲
 ▲
 ▲
 ▲

CHK	REV	REVISIONS
	A	
	B	ECO 8458
	C	ECO 9617
	D	ECO 20687
	E	ECO 13277
	F	ECO 122772

HONEYWELL
 INC
 COMPUTER CONTROL DIVISION
 Old Connecticut Path, Framingham, Mass

DR. D. HAMEL	DATE
ENG. R. ALBRIGHT	5/13/69
APP.	

PROJECT NO. 53217

TITLE
 H-316
 MEMORY EXPANSION
 ADDRESS GATING & DATA
 REGISTER BITS 1-5

SIZE DWG NO.
 C 70025828

REV.
 D

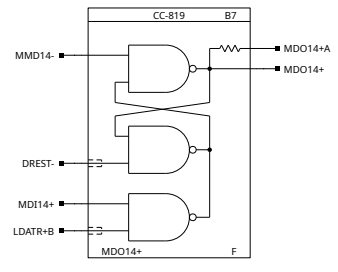
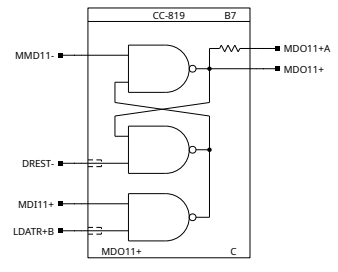
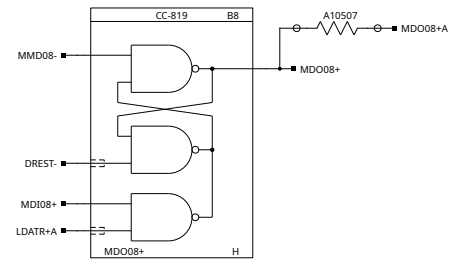
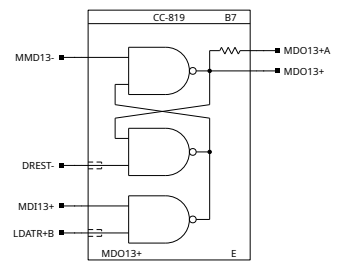
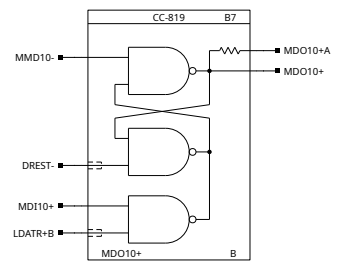
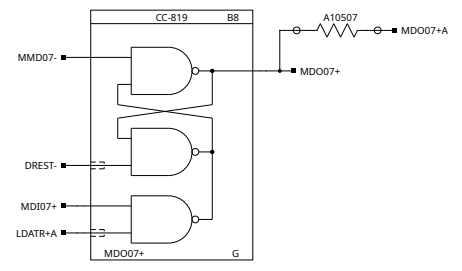
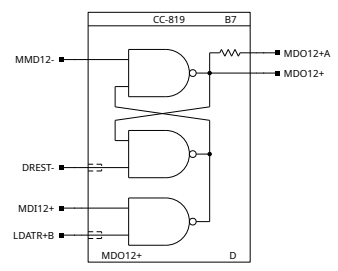
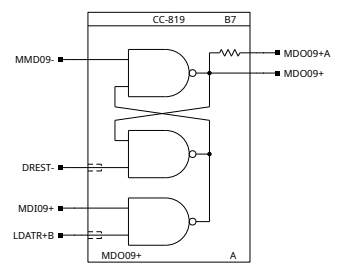
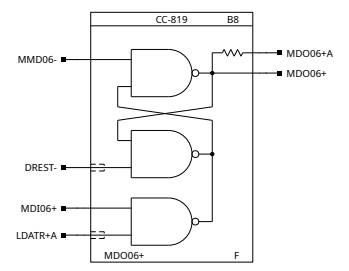

NOTES:
△
△
△
△

CHK	REV	REVISIONS	A
#	#		
S. R. 54-3915			
ECO 8458	B		
EXT. CHGS SEE ECO 312201	A.K.		
ECO 9490	C		
EXT. CHGS SEE ECO 614271	A.K.		
ECO 9617	D		
SEE ECO 112271	SSR		
ECO 20687	E		
SEE ECO 121472	T.L.R.		

HONEYWELL
INC
COMPUTER CONTROL DIVISION
Old Connecticut Path, Framingham, Mass

DR. D. HAMEL	DATE
ENG. R. ALBRIGHT	5/13/69
APP.	9/12/69

PROJECT NO. 53217

TITLE	H-316-0602
	MEMORY EXPANSION
	DATA REGISTER BITS 6-14
SIZE	DWG NO.
C	70025834
REV.	E

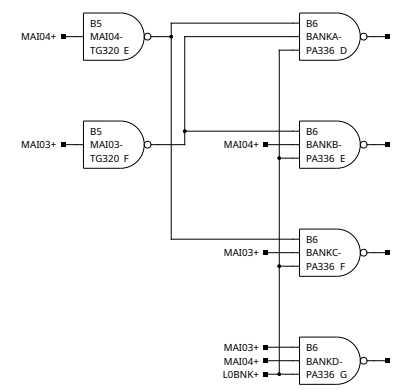
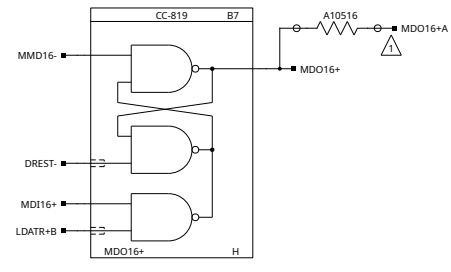
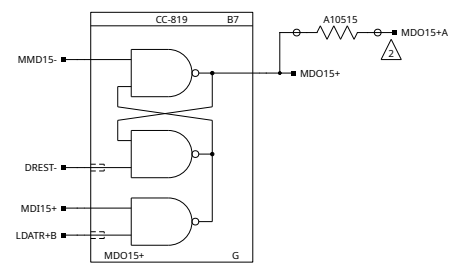

- NOTES-
- ADD A RESISTOR FROM B10720 TO A10516 ON THE BACKPLANE
 - ADD A RESISTOR FROM B10729 TO A10515 ON THE BACKPLANE
 -
 -

CHK	REVISIONS	REV.
	#	A
S. R. 54-3915		
ECO 8458	B	
EXT. CHGS SEE ECO 31220	A.K.	
ECO 9490	C	
EXT. CHGS SEE ECO 614271	A.K.	
ECO 9617	D	
SEE ECO 558		
21271		
ECO 20687	E	
SEE ECO 121372	T.L.R.	

HONEYWELL
INC
COMPUTER CONTROL DIVISION
Old Connecticut Path, Framingham, Mass

DR. D. HAMEL	DATE
ENG. R. ALBRIGHT	5/13/69
APP.	9/13/69

PROJECT NO. 53217

TITLE	H-316-0602
MEMORY EXPANSION	
DATA REGISTER BITS 15, 16 & BANK SIGNALS	
SIZE	DWG NO.
C	70025827
REV.	E

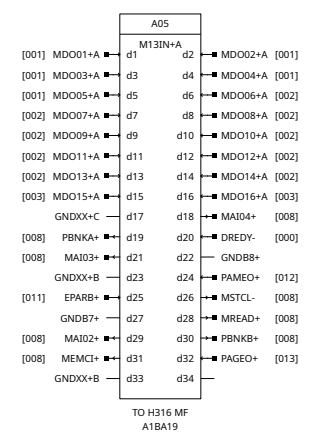
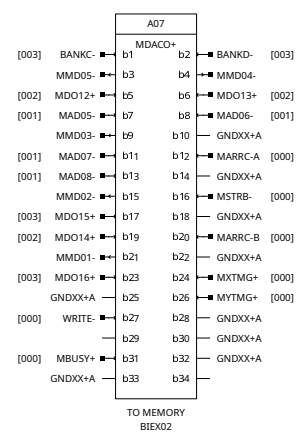
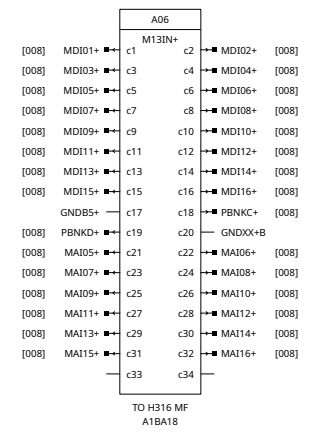
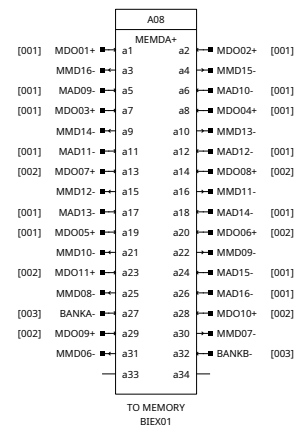

NOTES:
△
△
△
△

CHK	REV	DATE
ECO 20687	B	
SEE ECO 12227	T.L.R.	
S. R. 54-3915		

HONEYWELL
INC
COMPUTER CONTROL DIVISION
Old Connecticut Path, Framingham, Mass

DR. D. HAMEL DATE
ENG. R. ALBRIGHT 5/15/69
APP. 9/12/69

PROJECT NO. 53217

TITLE	H-316
MEMORY EXPANSION	
C.P. & MEMORY CONN.	
SIZE	DWG NO. 70025831
REV.	B

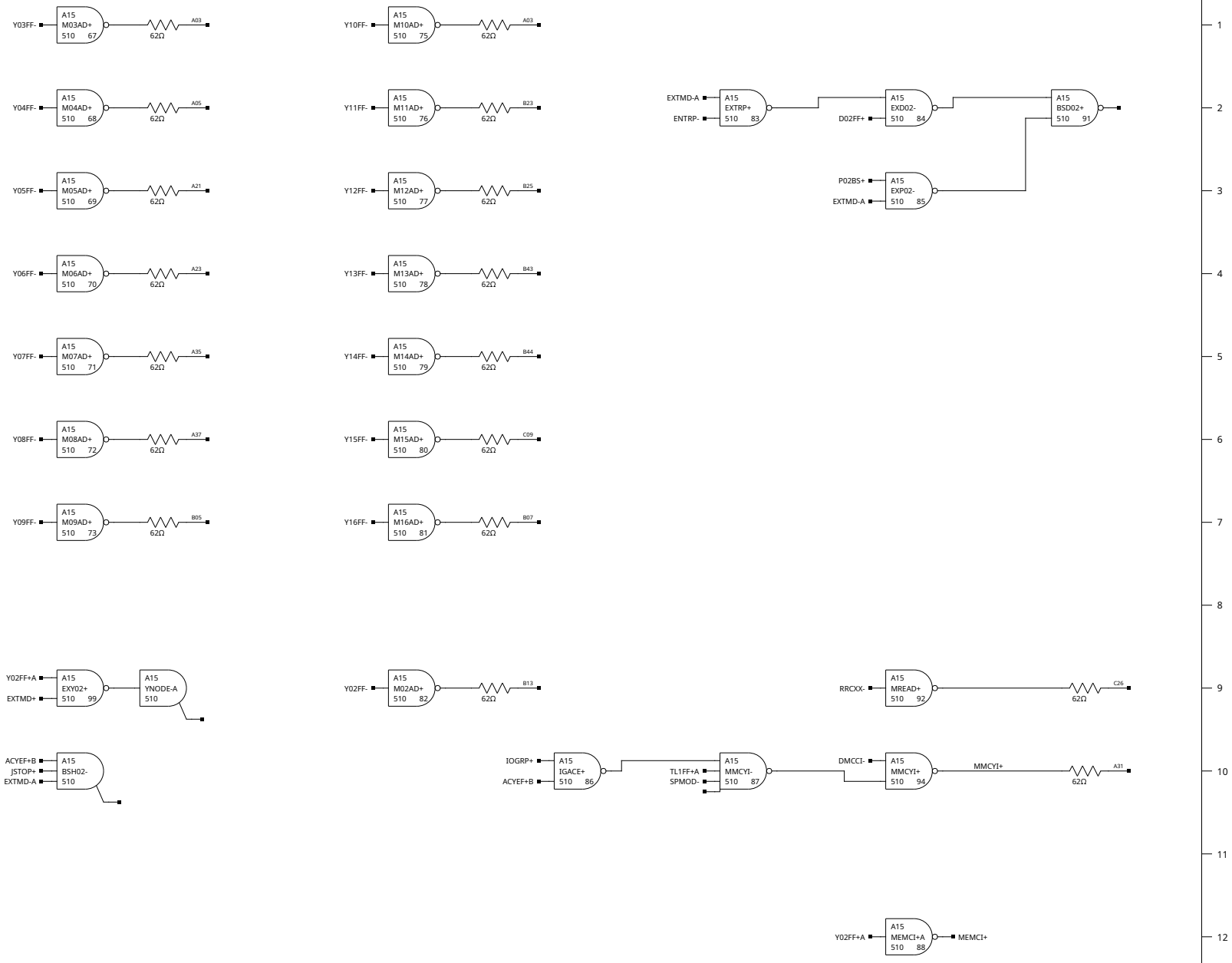

NOTES:
 ▲
 ▲
 ▲
 ▲

REV.	A
REVISIONS	—
CHK.	—
DATE	—
DESIGNER	S. R. 54-39115
ECO	20687
SEE ECO	122147Z -1221...TLR

HONEYWELL
 INC
 COMPUTER CONTROL DIVISION
 Old Connecticut Path, Framingham, Mass

DR. D. HAMEL	DATE
ENG. R. ALBRIGHT	5-16-69
APP.	9-12-69

PROJECT NO. 53217

TITLE	H-316
	MEMORY EXPANSION/PARITY
	ADDRESS AND CONTROL
SIZE	DWG NO.
C	70025833
REV.	B

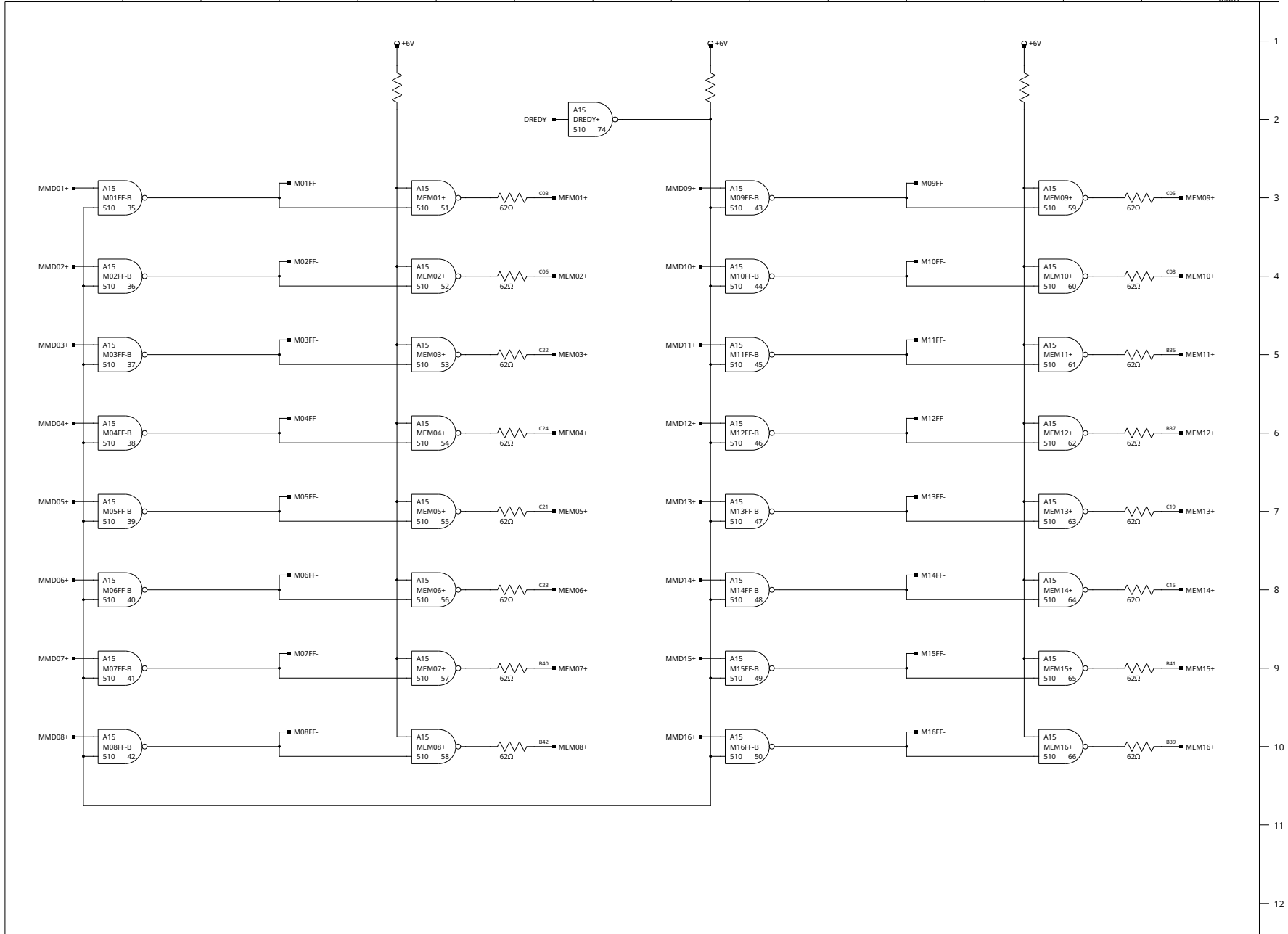

NOTES:
 ▲
 ▲
 ▲
 ▲

REV.	A
REVISIONS	
CHK.	
DATE	S. R. 54-3915
ECO	20687
SEE ECO	1216472 -121271 -TLR

HONEYWELL
 INC
 COMPUTER CONTROL DIVISION
 Old Connecticut Path, Framingham, Mass

DR. D. HAMEL	DATE
ENG. R. ALBRIGHT	5-12-69
APP.	9-12-69

PROJECT NO. 53217

TITLE	H-316
	MEMORY EXPANSION/PARITY
SIZE	DWG NO.
C	70025830
REV.	B

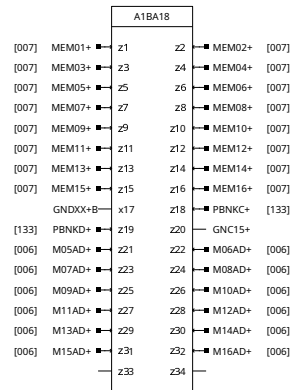

TO MEM. EXPAN 1X3 (A06) WHEN MEM. EXPAN. INSTALLED
TO PARITY MODULE (A07) WHEN 16K OR LESS PARITY INSTALLED

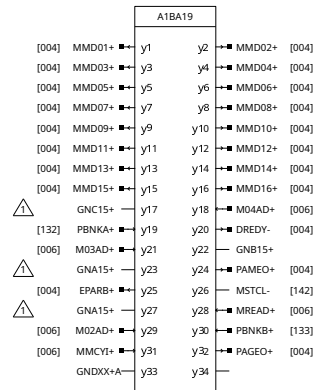

TO MEM. EXPAN 1X3 (A05) WHEN MEM. EXPAN. INSTALLED
TO PARITY MODULE (A08) WHEN 16K OR LESS PARITY INSTALLED

NOTES--
 △ SEE MAINFRAME COVER SHEET NOTES FOR WIRE CHANGES WHEN 16K OR LESS OF PARITY IS INSTALLED
 △
 △
 △

CHK	REV	A
#	REVISIONS	#
S. R.	544-3915	
ECO	20687	B
SEE ECO	121572	-1227_T.L.R.

HONEYWELL
 INC
 COMPUTER CONTROL DIVISION
 Old Connecticut Path, Framingham, Mass

DR. D. HAMEL	DATE
ENG. R. ALBRIGHT	5/16/69
APP.	9/12/69

PROJECT NO. 53217

TITLE	H-316
	MEMORY EXPANSION/PARITY
	C. P. CONNECTORS
SIZE	DWG NO.
C	70025832
REV.	B

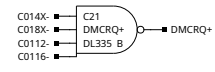
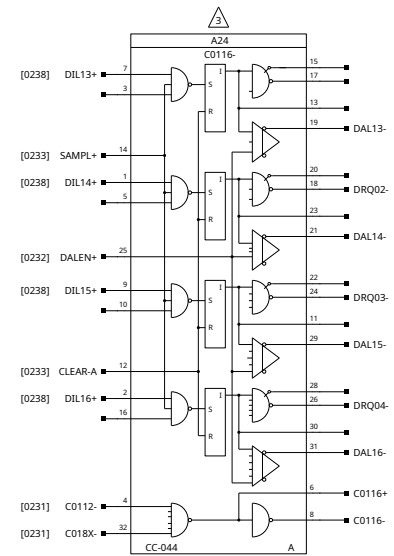
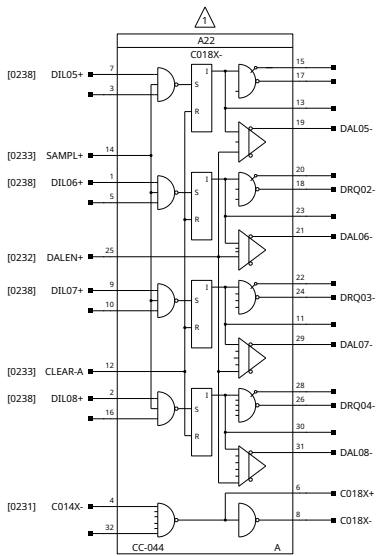
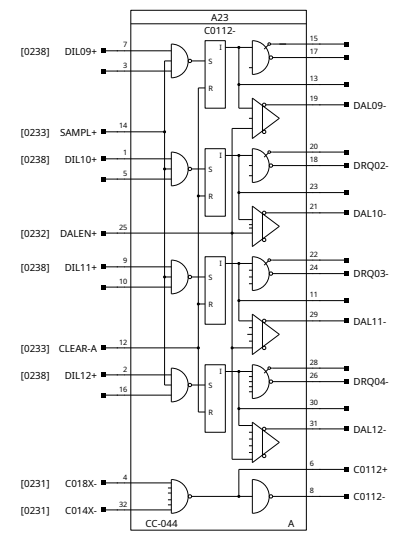
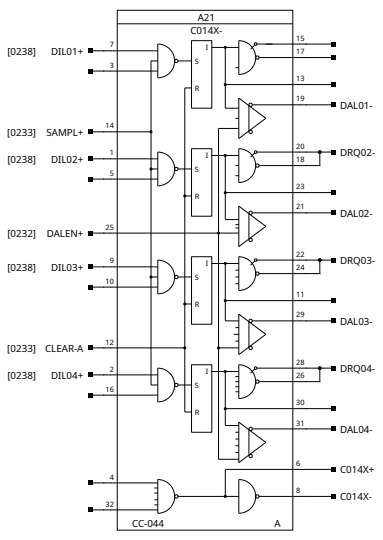

- NOTES-
- △ INSTALL IF MORE THAN 4 CHANNELS
 - △ INSTALL IF MORE THAN 8 CHANNELS
 - △ INSTALL IF MORE THAN 12 CHANNELS
 - △

CHK	REV	A
REVISIONS	#	
PER S. R. 54-3788		

HONEYWELL
INC
COMPUTER CONTROL DIVISION
Old Connecticut Path, Framingham, Mass

DR. A. KMCINSKI DATE 6/27/69
 ENG. K. ROY 8-22-69
 APP. K. ROY 8-22-69

PROJECT NO. 53202

TITLE	H-316 SDMC
	PRIORITY NET
SIZE	DWG NO.
C	70025578
REV.	A

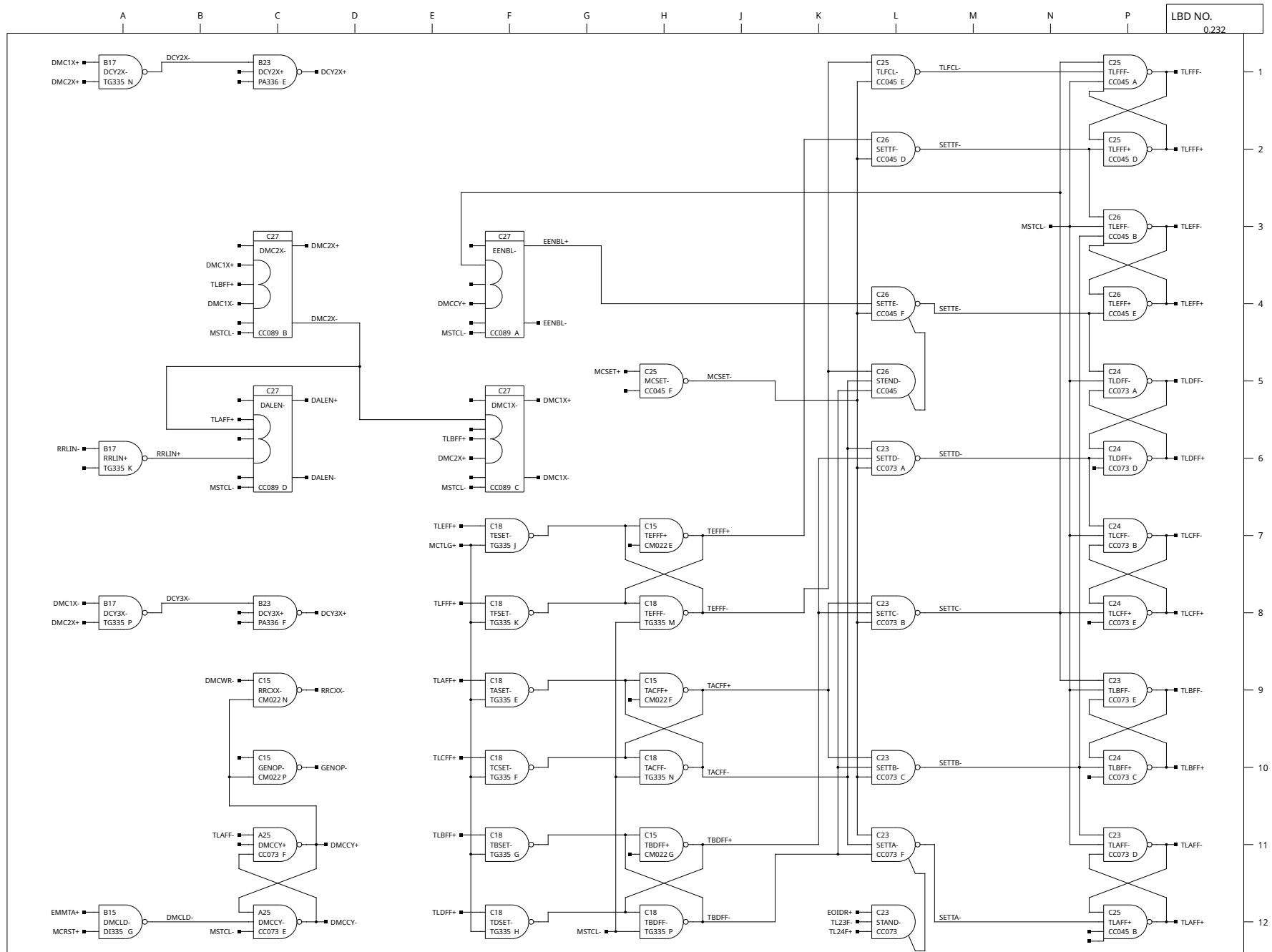

LBD NO.
0.232

NOTES:
△
△
△
△

REV.	DESCRIPTION
1	A

PER S. R. 54-3788

HONEYWELL
INC
COMPUTER CONTROL DIVISION
Old Connecticut Path, Framingham, Mass

DR. A. KMCINSKI	DATE
ENG. K. ROY	8-22-69
APP.	8-22-69

PROJECT NO. 53202

TITLE
H-316 SDMC
CYCLE & TLG

SIZE C DWG NO. 70025579 REV. A

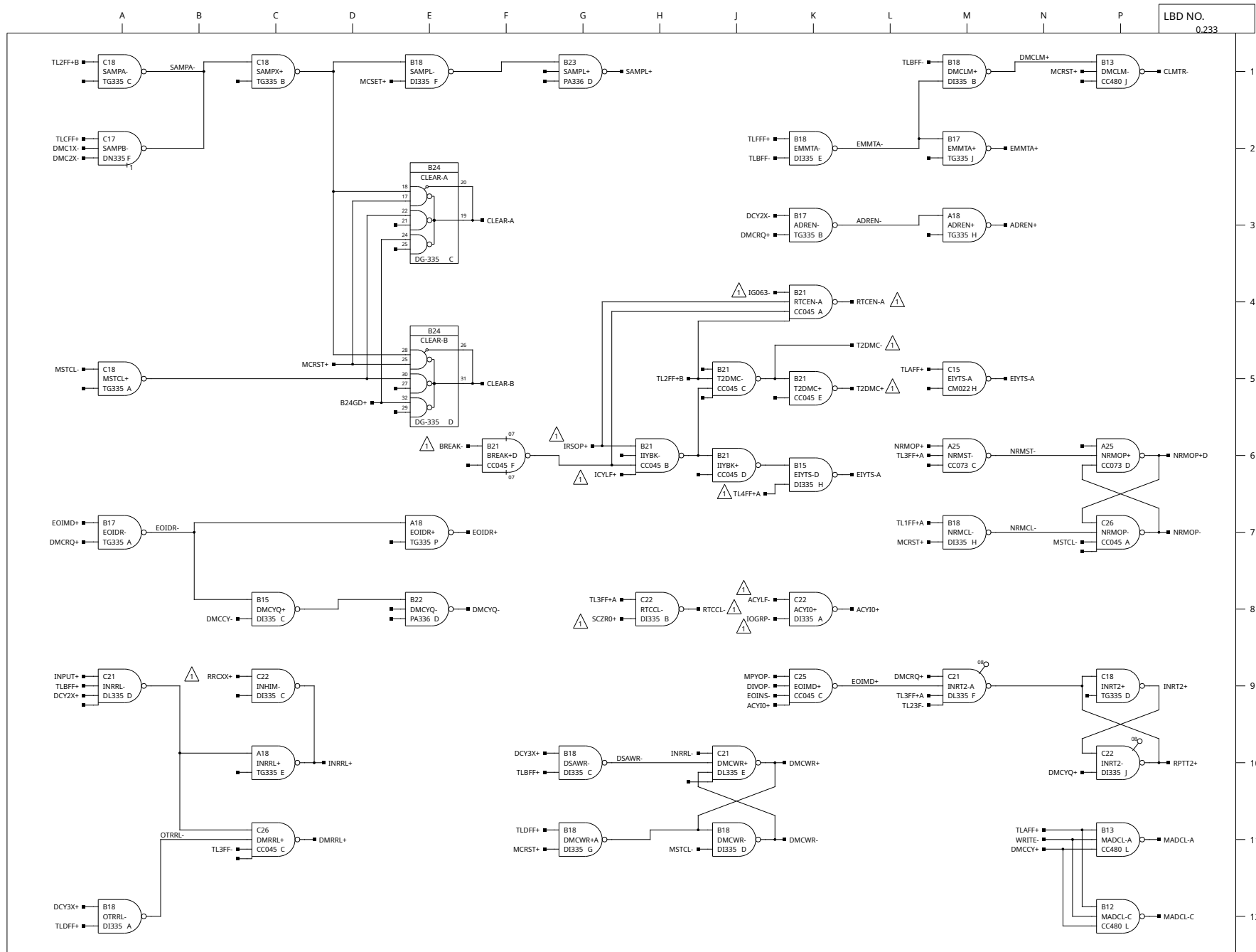

LBD NO.
0,233

- NOTES-
- △ SEE MAINFRAME COVER SHEET NOTE 9A
 - △
 - △
 - △
 - △

CHK	REVISIONS	REV.
	1	A
	2	B
	3	C
	4	D
	5	E
	6	F
	7	G
	8	H
	9	J
	10	K
	11	L
	12	M
	13	N
	14	P

HONEYWELL
INC
COMPUTER CONTROL DIVISION
Old Connecticut Path, Framingham, Mass

DR. A. KMICINSKI DATE 7/11/69
 ENG. K. ROY 8-22-69
 ADP. 8-22-69

PROJECT NO. 53202

TITLE	H-316 SDMC CONTROL
SIZE	DWG NO. 70025580
REV.	E

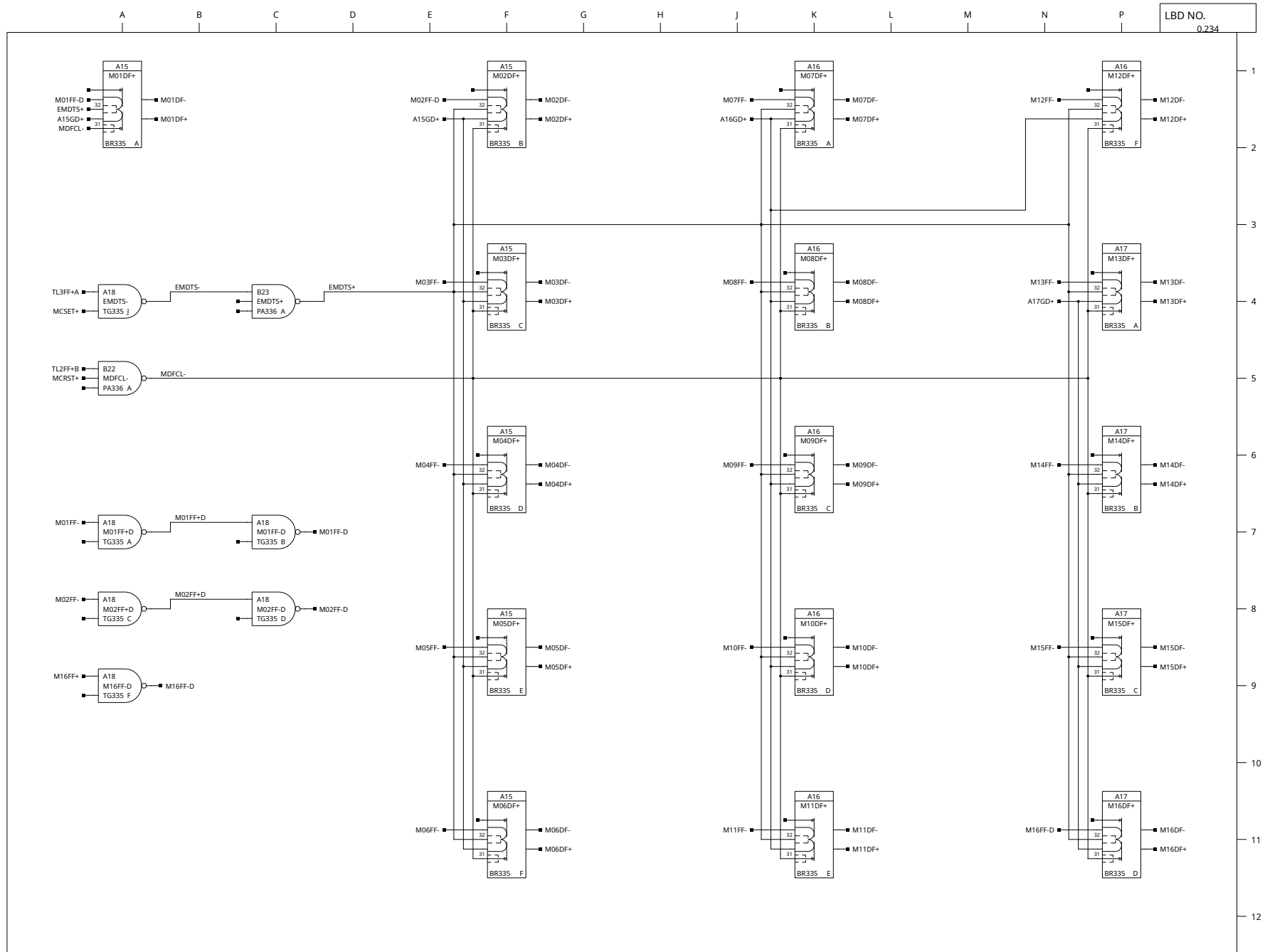

LBD NO.
0.234

NOTES:
 △
 △
 △
 △

REV.	DATE	BY	CHKD.
A			
B			
C			
D			
E			
F			
G			
H			
I			
J			
K			
L			
M			
N			
O			
P			

PER S. R. 54-3788

HONEYWELL
 INC.
 COMPUTER CONTROL DIVISION
 Old Connecticut Path, Framingham, Mass

DR. A. KMICINSKI	DATE 8-22-69
ENG. K. ROY	8-22-69
APP.	8-22-69

TITLE
H-316 SDMC
M-REG STORAGE

SIZE DWG NO. REV.
C 70025581 A

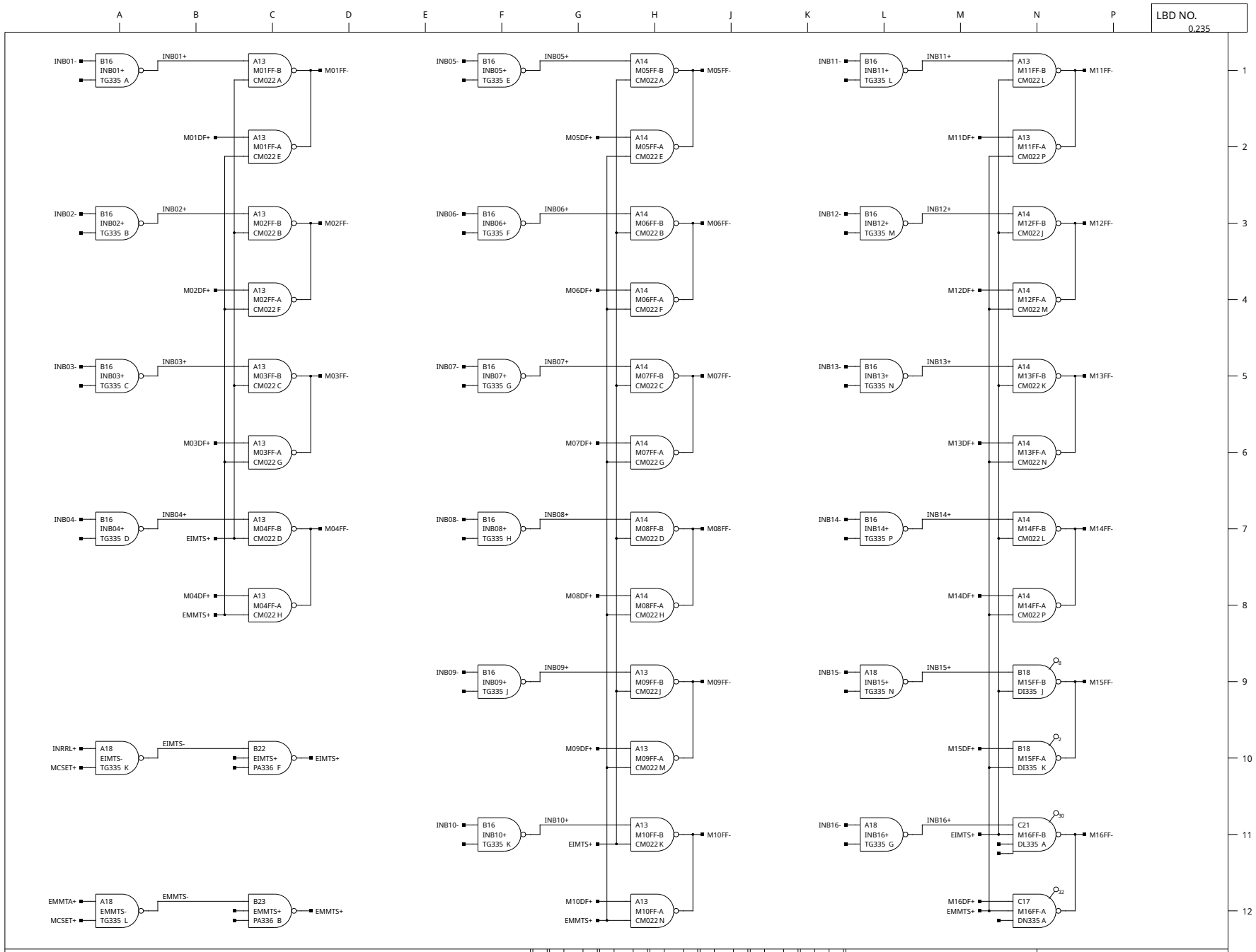

LBD NO.
0.235

NOTES:
 △
 △
 △
 △

REV.	REVISIONS	DATE
A	PER S R	7/1/69
B	ECO 7904	8-22-69
	EXT. CHANGES SEE ECO 7897D	8-22-69

HONEYWELL
 INC.
 COMPUTER CONTROL DIVISION
 Old Connecticut Path, Framingham, Mass.

DR. A. KMICINSKI
 ENG. K. ROY
 ADP.

DATE
 8-22-69
 8-22-69

TITLE
 H-316 SDMC
 M-REG INPUT

SIZE C DWG NO. 70025582

REV. B

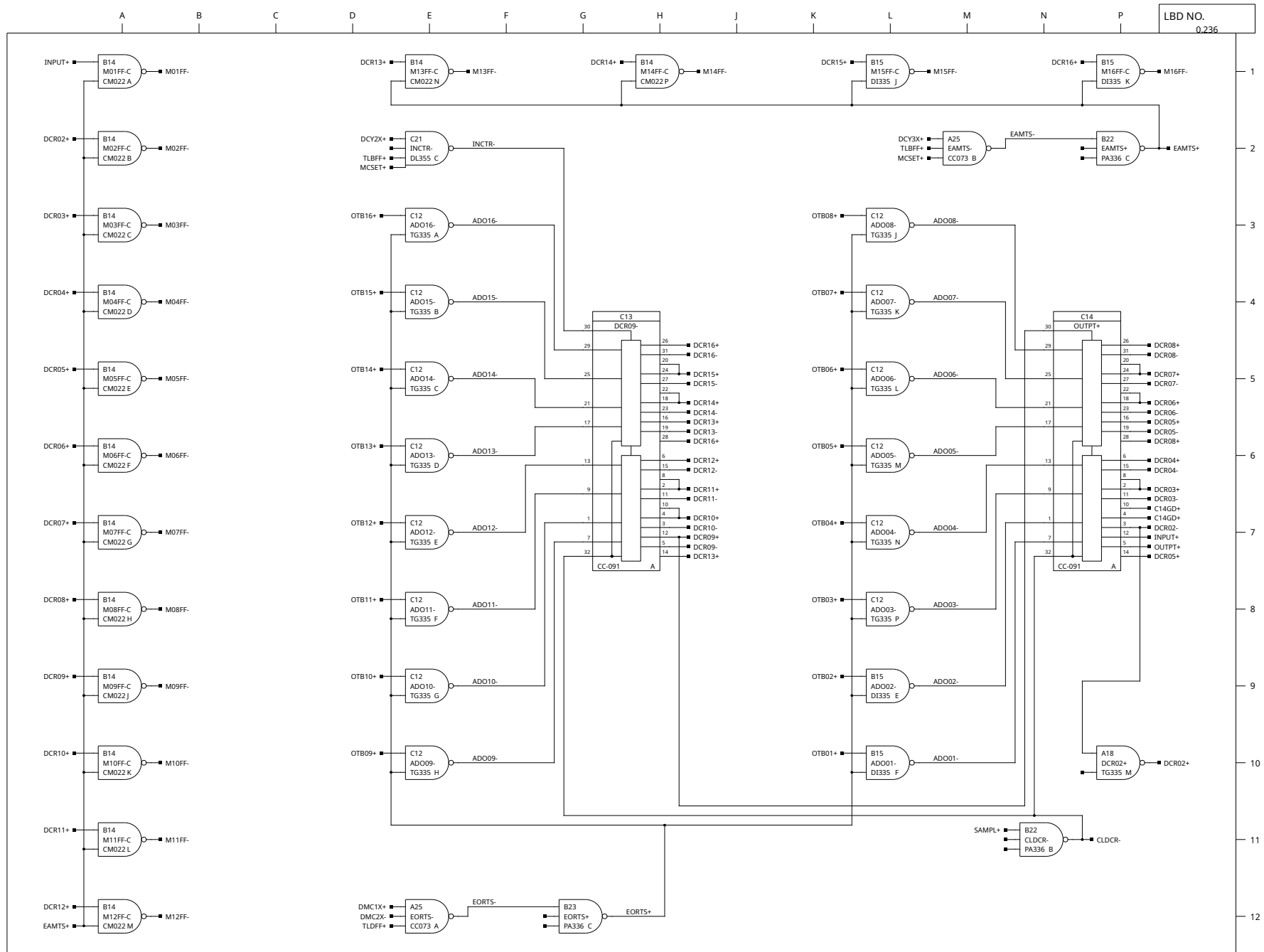

LBD NO.
0.236

NOTES:
△
△
△
△

REV.	DESCRIPTION
A	PER S. R. 54.3788
B	ECO 851664 EAC
	PER CH 12/1973

HONEYWELL
INC
COMPUTER CONTROL DIVISION
Old Connecticut Path, Framingham, Mass

DR. A. KMICINSKI	DATE 7/3/69
ENG. K. ROY	8-22-69
APP.	8-22-69

PROJECT NO. 53202

TITLE
H-316 SDMC
ADDRESS REG.

SIZE C	DWG NO. 70025583	REV. B
--------	------------------	--------

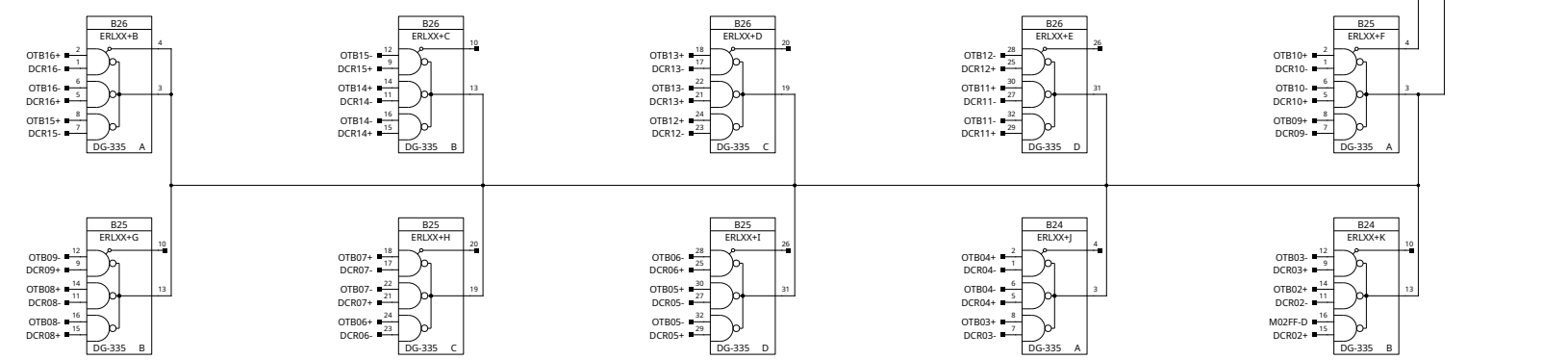
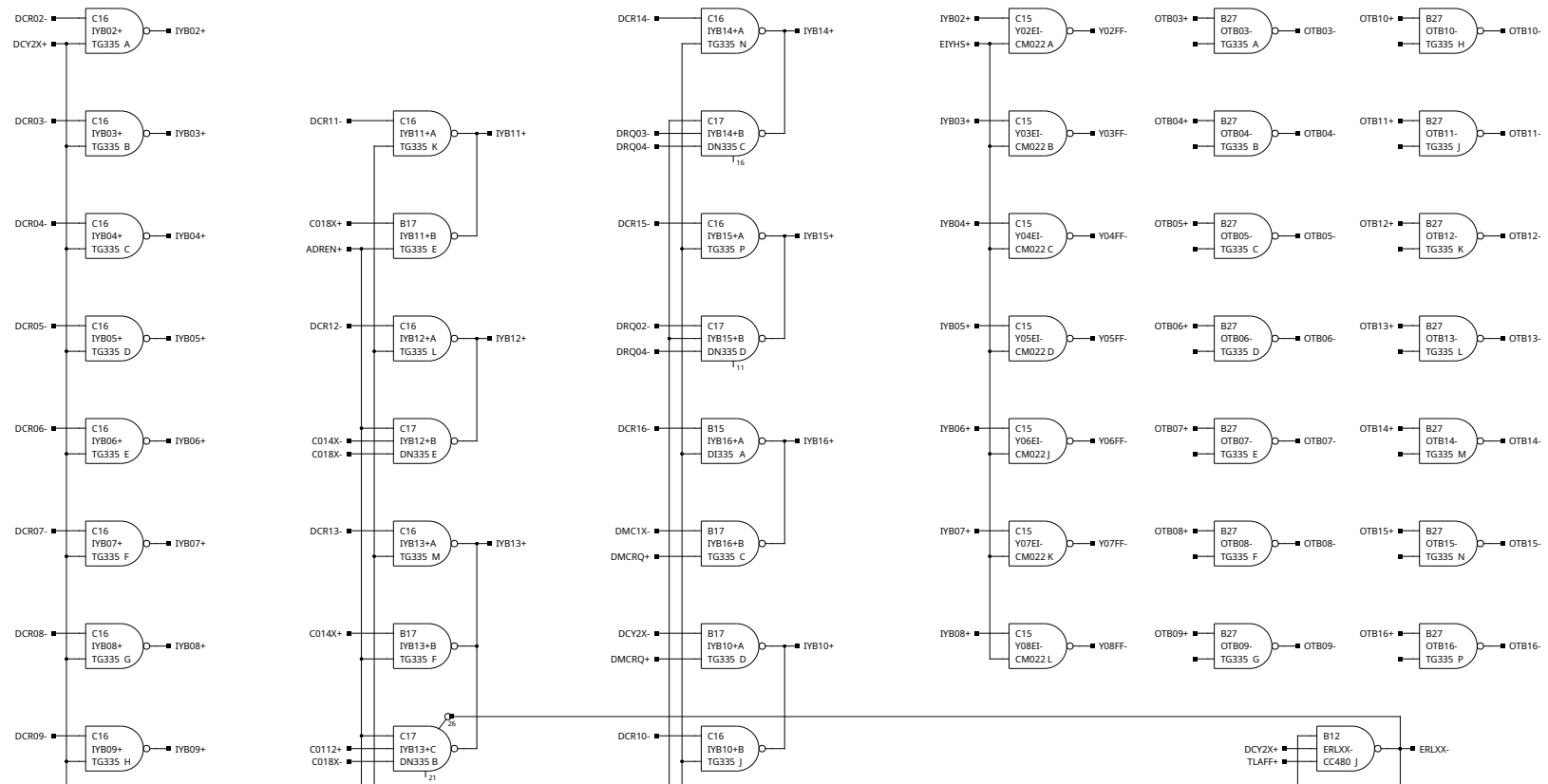

NOTES:
 ▲
 ▲
 ▲
 ▲

REV.	REVISIONS	DATE
A	PER S.R. 54. 3788	
B	ECO 10168	
	SSEEEO 2/29/72	
	S.S.R.	

HONEYWELL
 INC
 COMPUTER CONTROL DIVISION
 Old Connecticut Path, Framingham, Mass

DR. A. KMICINSKI DATE 7/7/69
 ENG. K. ROY 8-22-69
 ADP. 8-22-69

PROJECT NO. 53202

TITLE	H-316 SDMC
	COMPARATOR/IYB
SIZE	DWG NO.
C	7002584
REV.	B

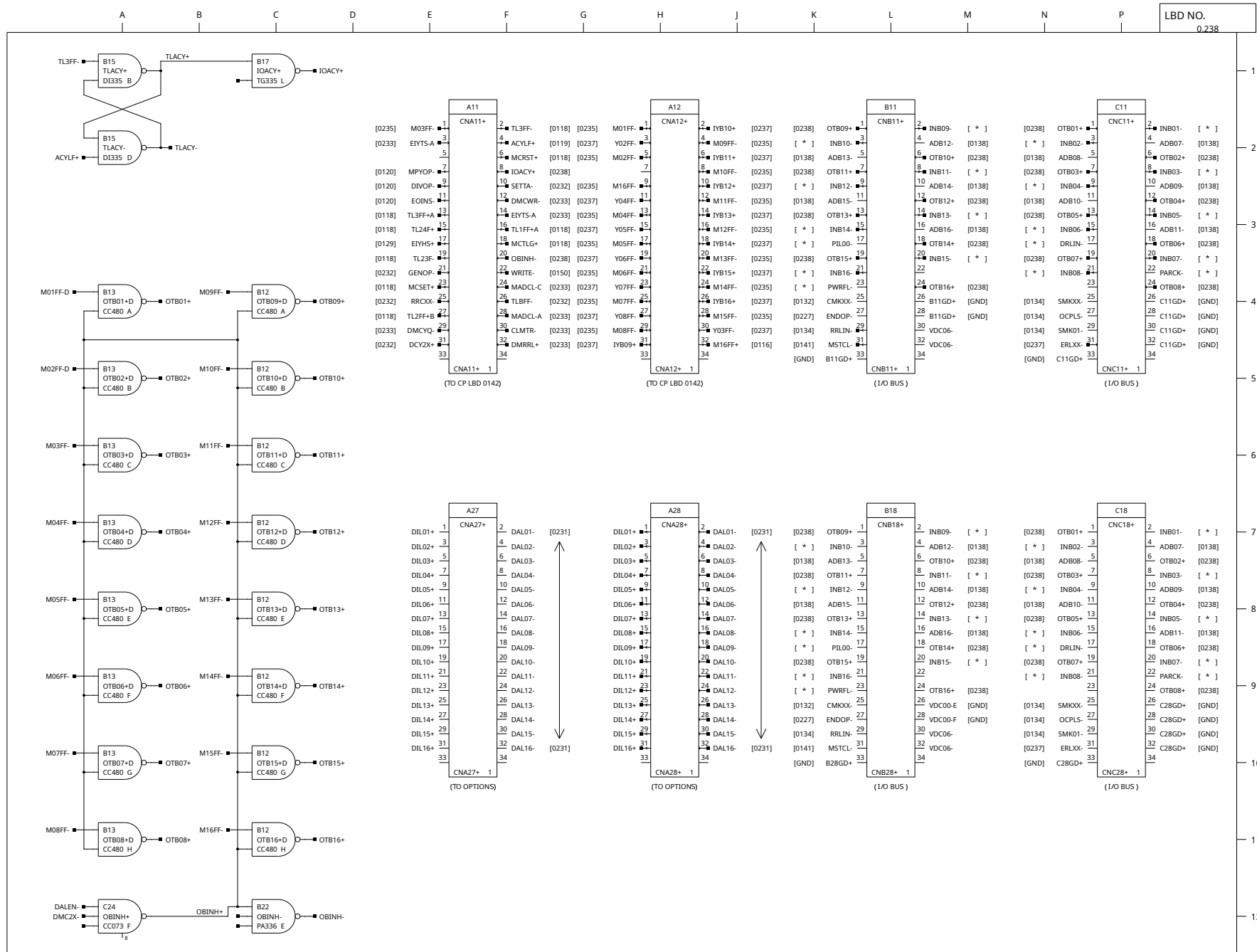

LBD NO.
0,238

NOTES:-
 △ [*] THESE SIGNALS ARRIVE BY BUS FROM I/O OPTIONS
 △
 △
 △

REV.	REVISIONS	PER.S.R.	ECO 79/04	ECO 84/25	ECO 94/25	ECO 101/89
A		54.3788	SEE ECO 1/8/77/0	SEE ECO 5/7/77/1	SEE ECO 2/5/72	

HONEYWELL
 INC
 COMPUTER CONTROL DIVISION
 Old Connecticut Path, Framingham, Mass

DR. A. KMICINSKI	DATE 7/8/69
ENG. K. ROY	8-22-69
APP.	8-22-69

TITLE	H-316 SDMC	REV.	D
	CABLE & OUT BUS	SIZE	C
		DWG NO.	70025585

PROJECT NO. 53202

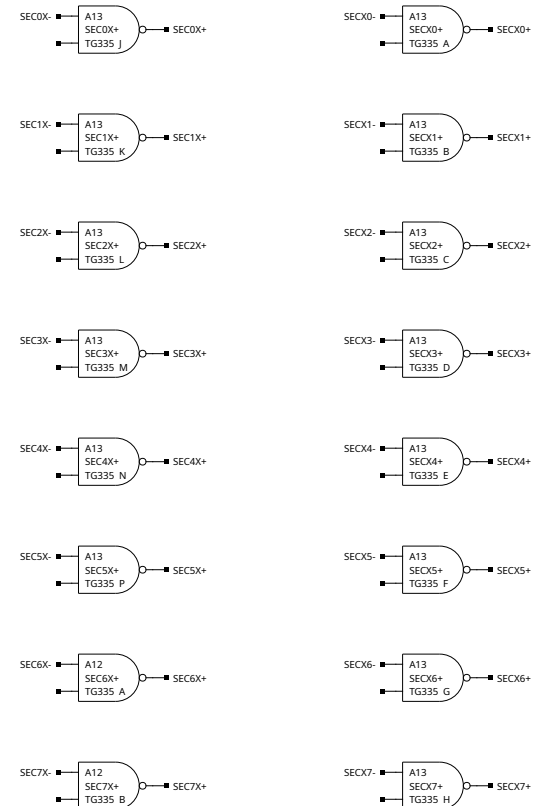
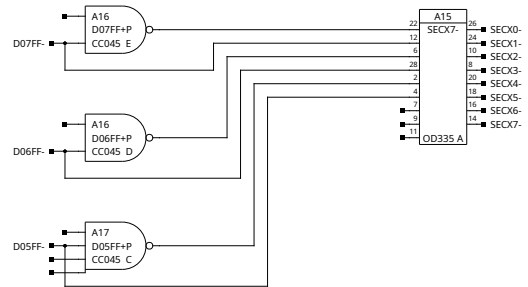
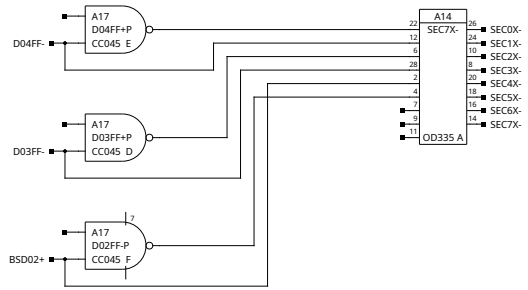

NOTES-

- △ THIS POINT GND WITH NO EXT. ADDRESSING OPTION
- △
- △
- △
- △

REV.	A
REVISIONS	
CHK.	
#	
S. I. R.	664-4192

HONEYWELL
INC
COMPUTER CONTROL DIVISION
Old Connecticut Path, Framingham, Mass

DR. D. HAMEL	DATE
ENG. K. ROY	11/4/69
APP.	11/5/69

PROJECT NO. 53218

TITLE	H-316-08
	ML SECTOR DECODE
SIZE	DWG NO.
C	70027535
REV.	/

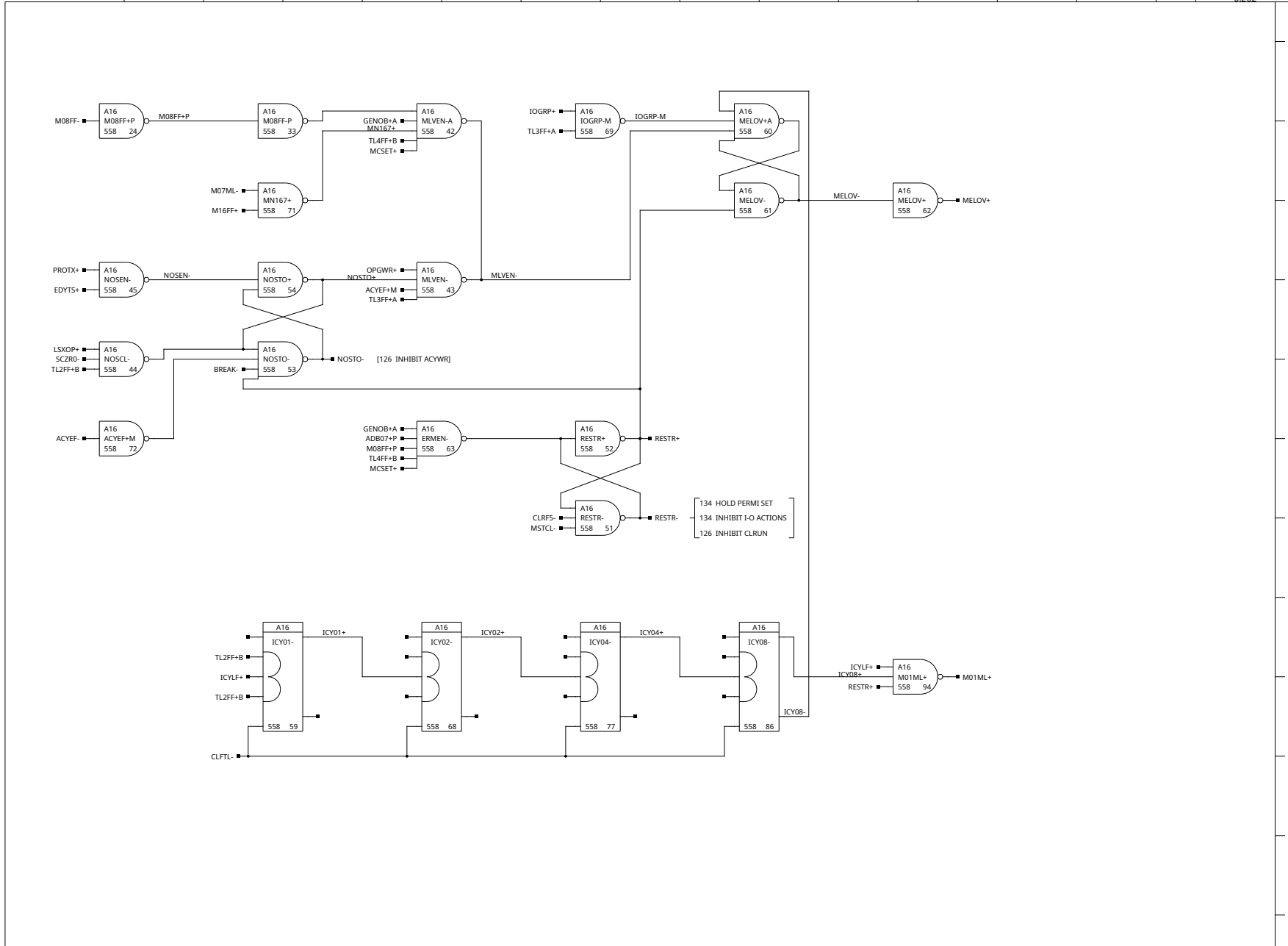

NOTES:
 △
 △
 △
 △

REV.	DESCRIPTION
A	
S. R. 664-4192	

HONEYWELL
 INC
 COMPUTER CONTROL DIVISION
 Old Connecticut Path, Framingham, Mass

DR. A. KMICINSKI	DATE
ENG. K. ROY	11/4/69
APP.	11/5/69

PROJECT NO. 53218

TITLE	H-316-08
	MLO CONTROL
SIZE	DWG NO.
C	70027536
REV.	/

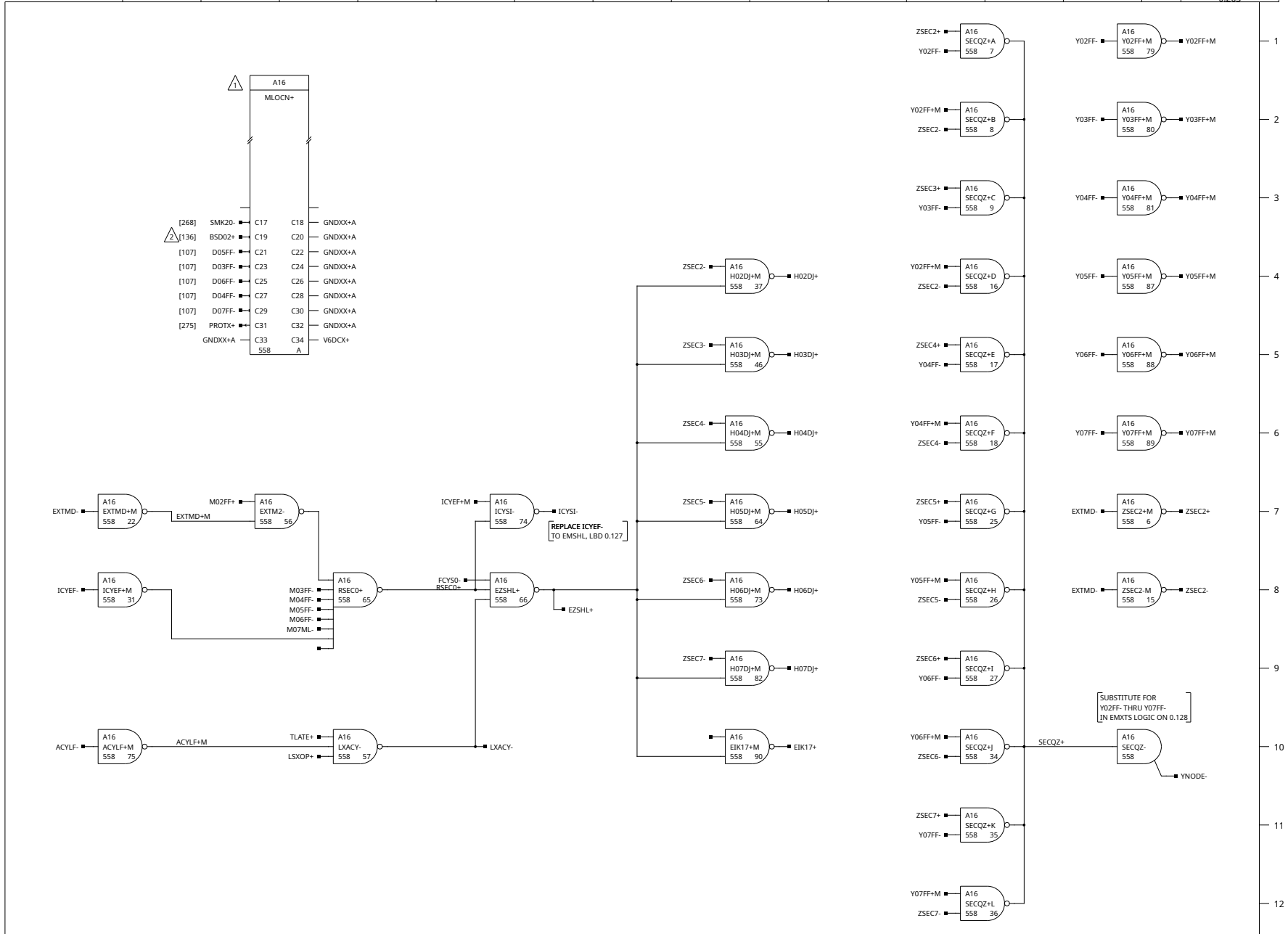

NOTES-

- △ THESE SIGNALS ARE CONNECTED TO SLOT A18 OF THE FIRST MLO 1X3 μ-BLOCK BY MEANS OF A TWISTED PAIR CABLE
- △ THIS POINT GROUND WITH NO EXTENDED ADDRESSING OPTION
- △
- △

REV.	A
CHG.	
REVISIONS	
S. R.	664-4192

HONEYWELL
INC
COMPUTER CONTROL DIVISION
Old Connecticut Path, Framingham, Mass

DR. D. HAMEL	DATE
ENG. K. ROY	11/4/69
APP.	11/5/69

PROJECT NO. 53218

TITLE	H-316-08
	ML BASE SECTOR RELOCATION
SIZE	DWG NO.
C	70027537
REV.	/

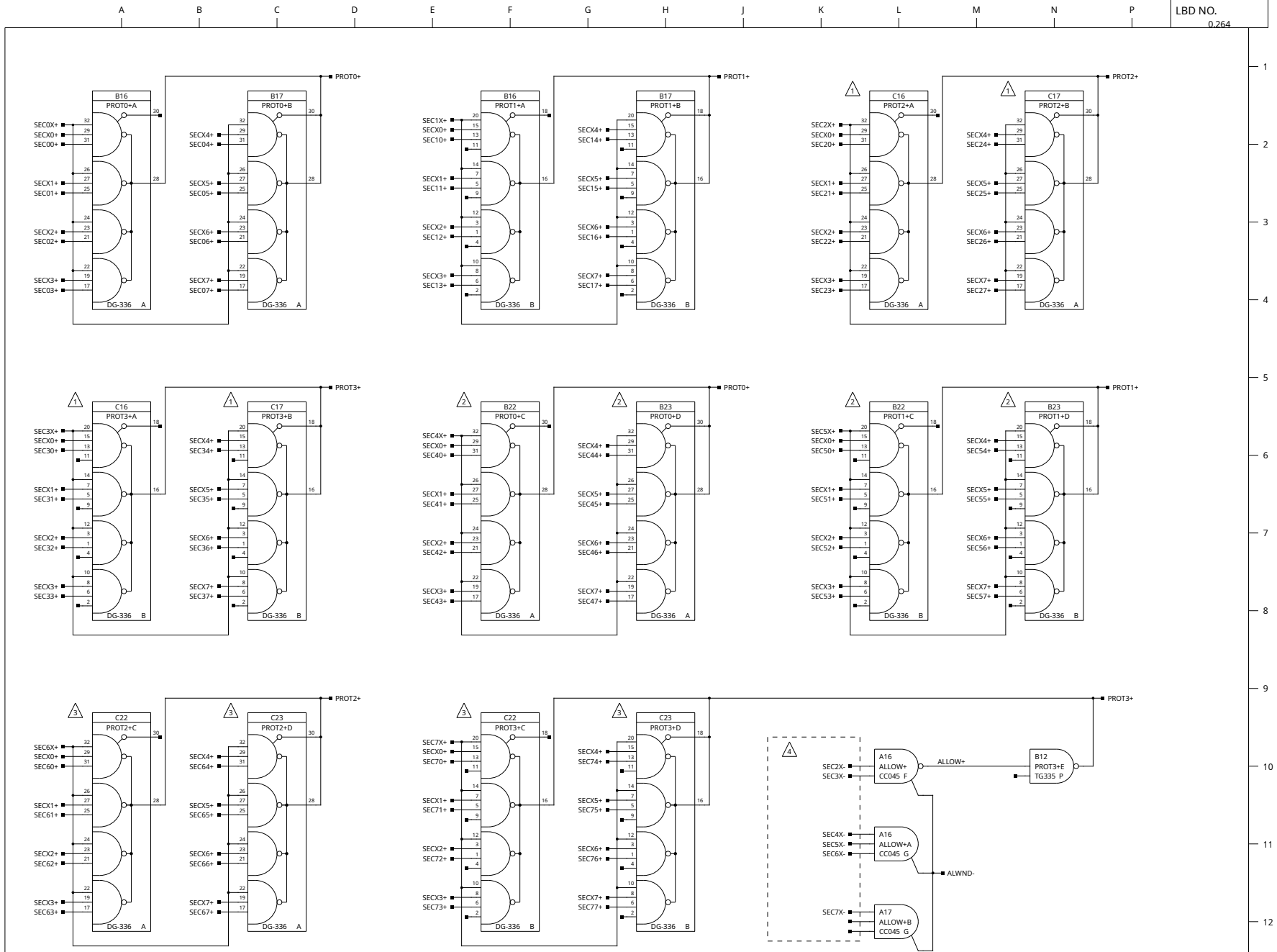

- NOTES-**
- ⚠ THESE PACS INCLUDED IF MORE THAN 8K MLO.
 - ⚠ THESE PACS INCLUDED IF MORE THAN 16K MLO.
 - ⚠ THESE PACS INCLUDED IF MORE THAN 24K MLO.
 - ⚠ SIGNALS WITHIN THIS BLOCK ARE ONLY ADDED WHEN APPLICABLE (SEE WIRE LIST NOTES)

REV.	DESCRIPTION	DATE
1	A	
2		
3		
4		
5		
6		
7		
8		
9		
10		
11		
12		

S. R. 664-4192

HONEYWELL
INC
COMPUTER CONTROL DIVISION
Old Connecticut Path, Framingham, Mass

DR. D. HAMEL	DATE
ENG. K. ROY	11/4/69
APP.	11/5/69

PROJECT NO. 53218

TITLE	H-316-08
	ML PROTECT DECODER
SIZE	DWG NO.
C	70027538

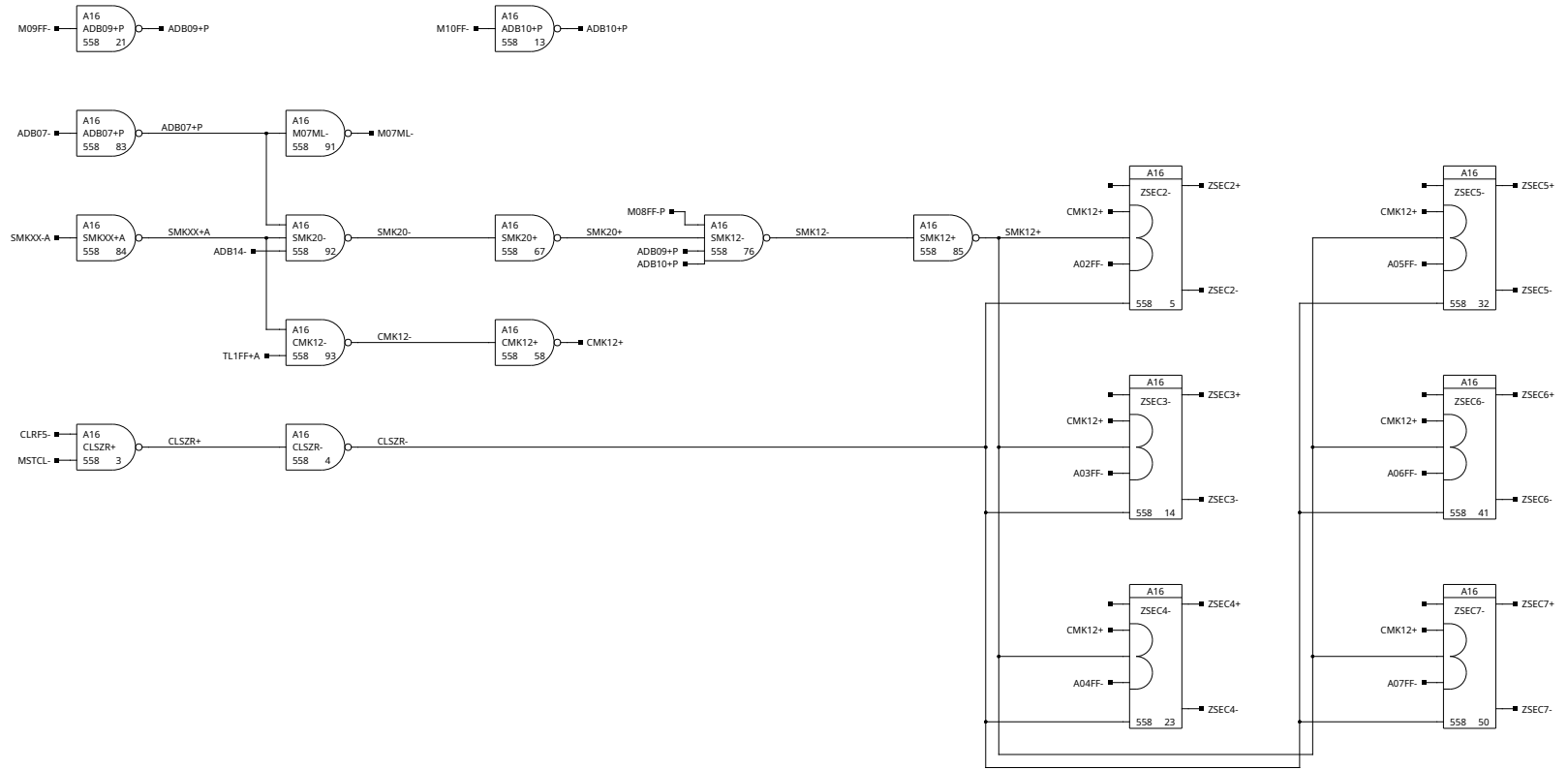

NOTES-

- △
- △
- △
- △

REV.	A
REVISIONS	
CHK.	
#	
S. I. R.	664-4192

HONEYWELL
INC
COMPUTER CONTROL DIVISION
Old Connecticut Path, Framingham, Mass

DR. D. HAMEL	DATE
ENG. K. ROY	11/4/69
APP.	11/5/69

TITLE	H-316-08
	Z SEC REGISTER
PROJECT NO.	53218
SIZE	DWG NO.
C	70027539
REV.	/

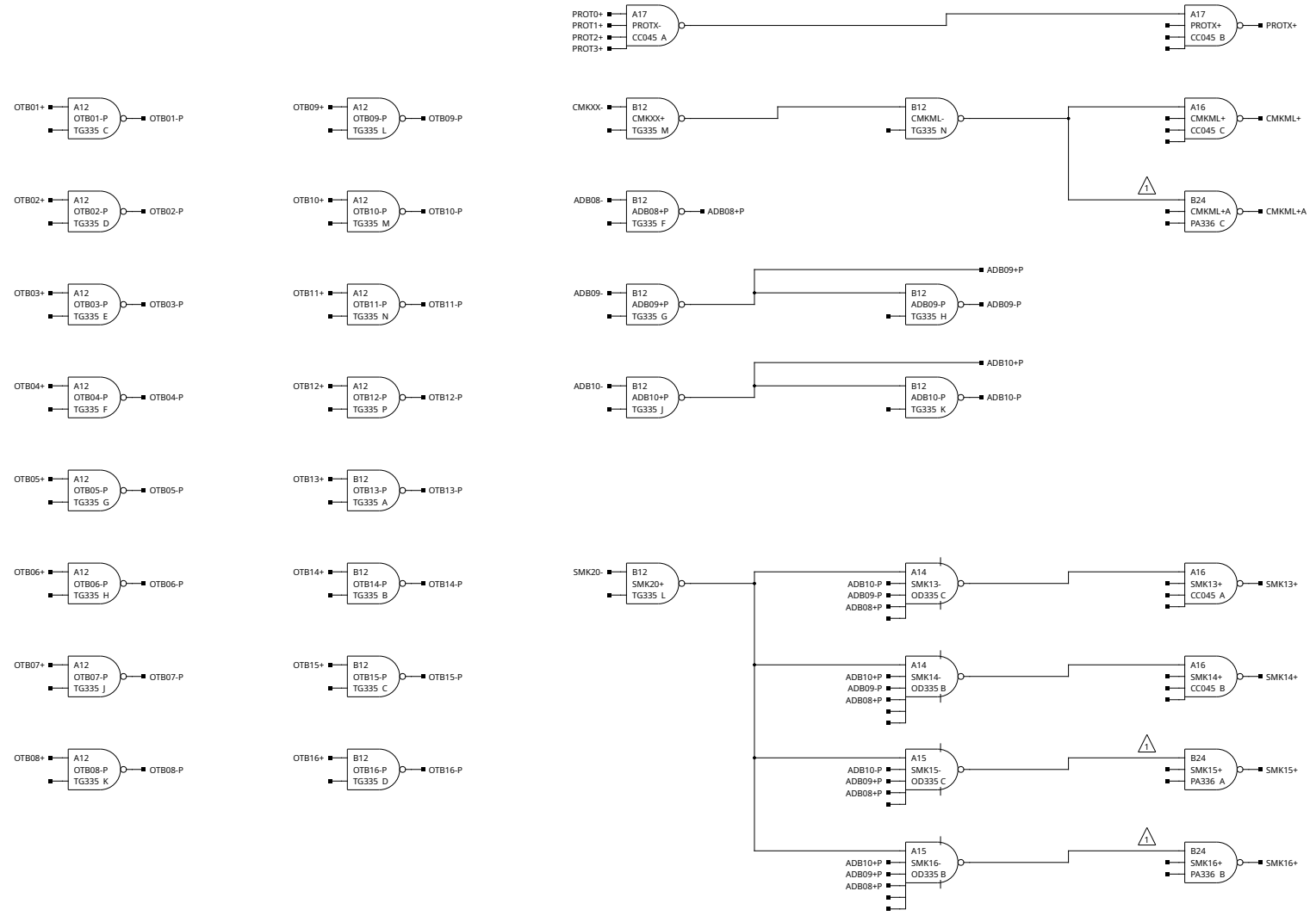

NOTES:-
 ▲ THESE GATE INCLUDED IF MORE THAN 16K MLO
 ▲
 ▲
 ▲

REV.	A
CHG.	REV.
S. R.	664-4192
ECO	9488
EXT CHG	PER ECO 9488 - 5/10/71

HONEYWELL
 INC
 COMPUTER CONTROL DIVISION
 Old Connecticut Path, Framingham, Mass

DR. D. HAMEL	DATE
ENG. K. ROY	11/4/69
APP.	11/5/69

PROJECT NO. 53218

TITLE	H-316-08
MLO EXTERNAL	I/O BUS INTERFACE
SIZE	DWG NO.
C	70027540
REV.	B

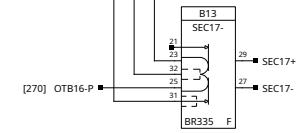
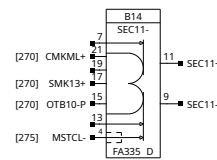
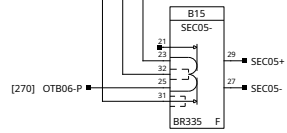
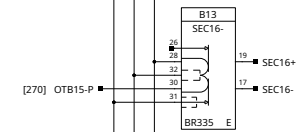
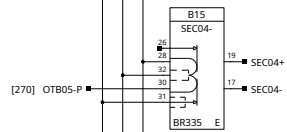
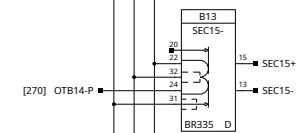
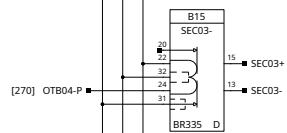
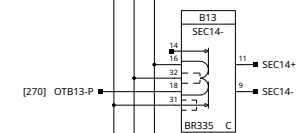
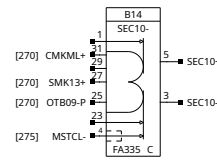
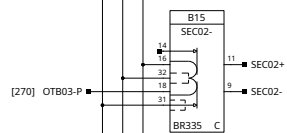
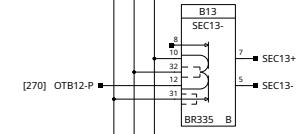
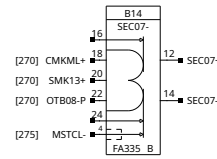
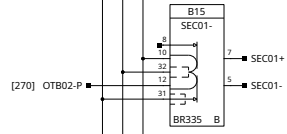
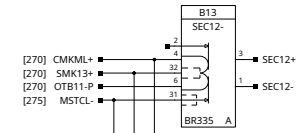
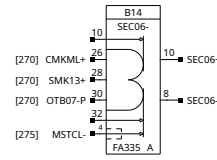
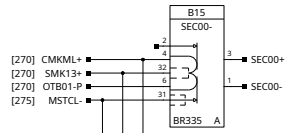

NOTES-

- △
- △
- △
- △

REV.	DESCRIPTION
A	
#	#

S. R. 664-4192

HONEYWELL
INC
COMPUTER CONTROL DIVISION
Old Connecticut Path, Framingham, Mass

DR. D. HAMEL	DATE
ENG. K. ROY	11/4/69
APP.	11/5/69

PROJECT NO. 53218

TITLE
H-316-08
LOCKOUT MASK REGISTER #1

SIZE	DWG NO.	REV.
C	70027541	/

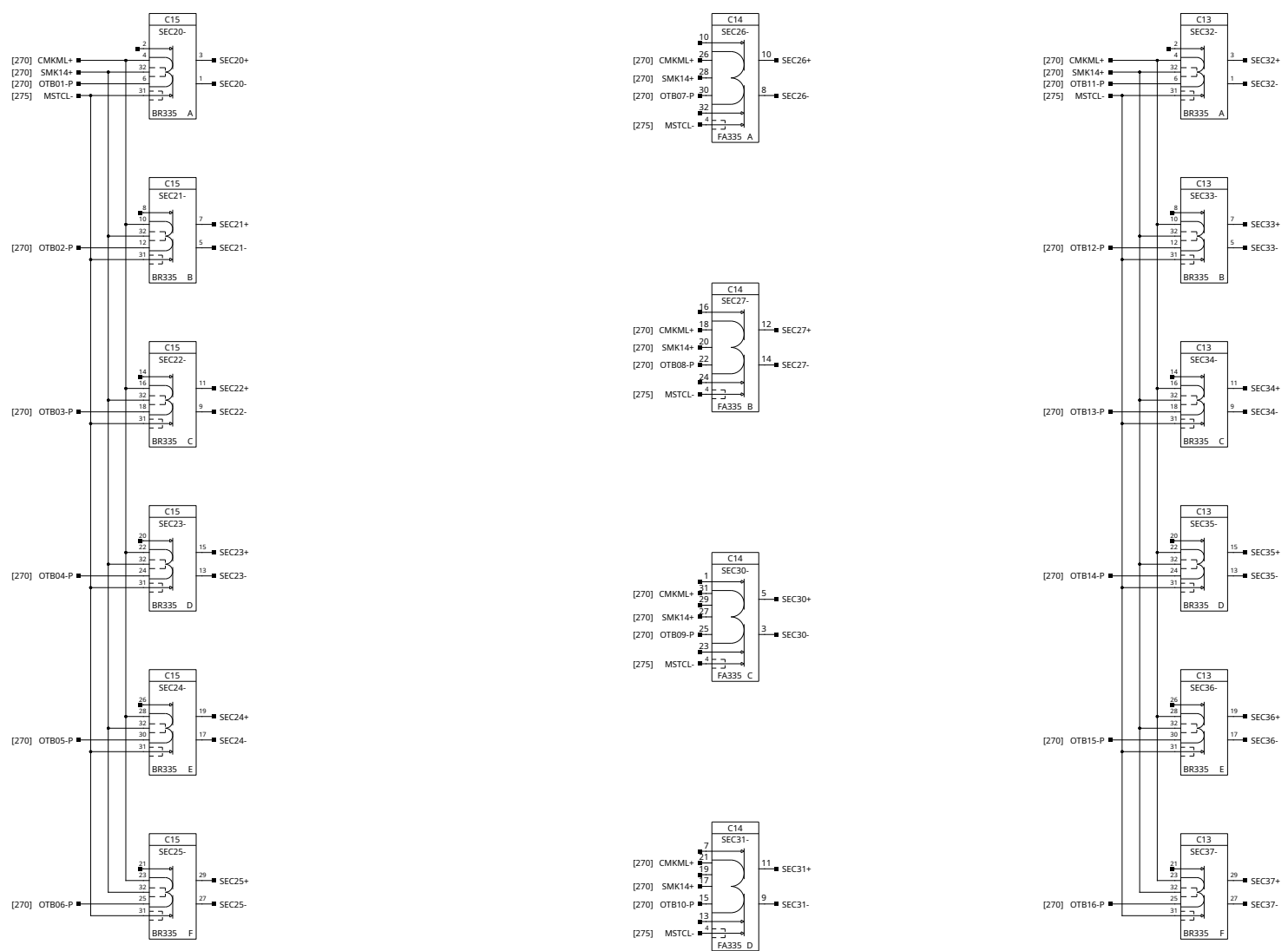

1
2
3
4
5
6
7
8
9
10
11
12

NOTES-
 ▲ ALL PACS THIS PAGE INCLUDED IF MORE THAN 8K OF MLO.
 ▲
 ▲
 ▲
 ▲

REV.	A
REVISIONS	
CHK	S. R. 664

HONEYWELL
 INC
 COMPUTER CONTROL DIVISION
 Old Connecticut Path, Framingham, Mass

DR. D. HAMEL	DATE
ENG. K. ROY	11/4/69
APP.	11/5/69

PROJECT NO. 53218

TITLE
 H-316-08
 LOCKOUT MASK REGISTER #2

SIZE	DWG NO.	REV.
C	70027542	/

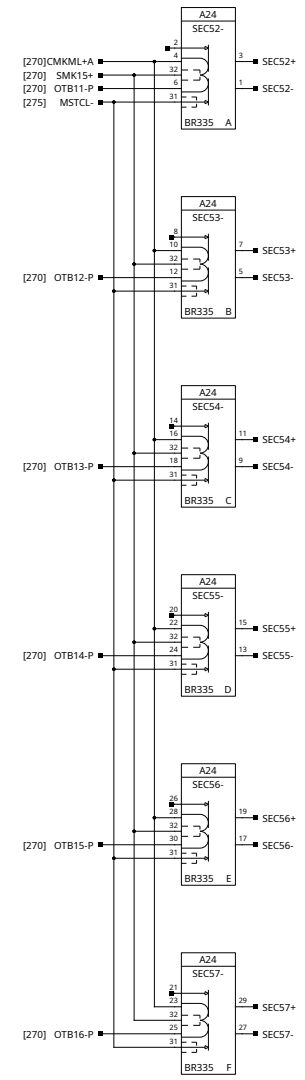
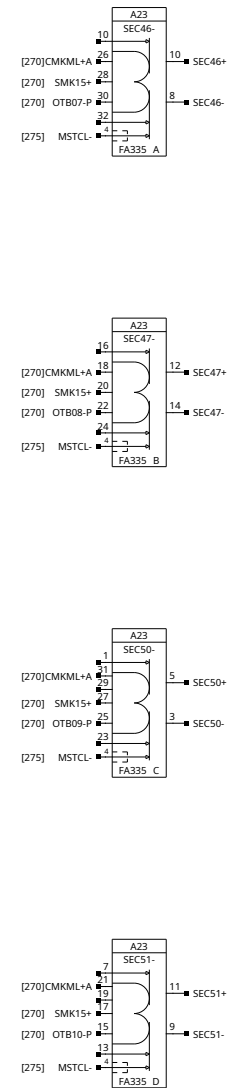
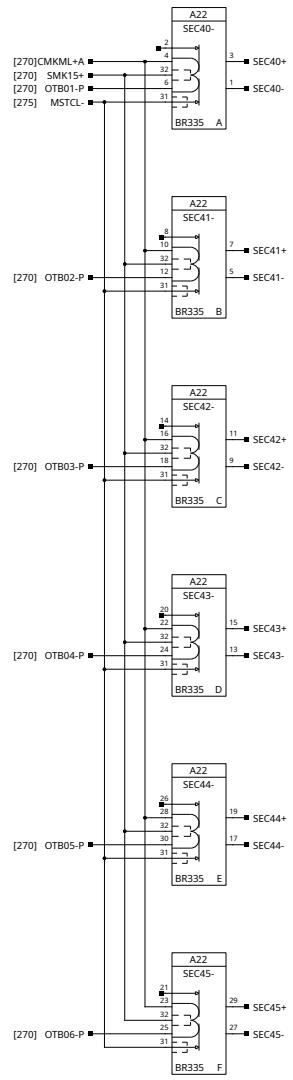

NOTES:
 ▲ ALL PACS THIS PAGE INCLUDED IF MORE THAN 16K OF MLO.
 ▲
 ▲
 ▲

REV.	A
REVISIONS	— / —
CHK.	— / —
S. R. 664-4192	

HONEYWELL
 INC
 COMPUTER CONTROL DIVISION
 Old Connecticut Path, Framingham, Mass

DR. D. HAMEL	DATE
ENG. K. ROY	11/4/69
APP.	11/5/69

PROJECT NO. 53218

TITLE
 H-316-08
 LOCKOUT MASK REGISTER #3

SIZE	DWG NO.	REV.
C	70027543	/

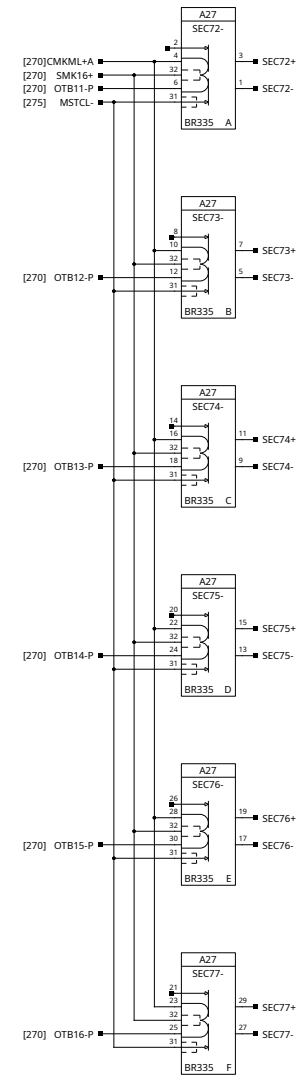
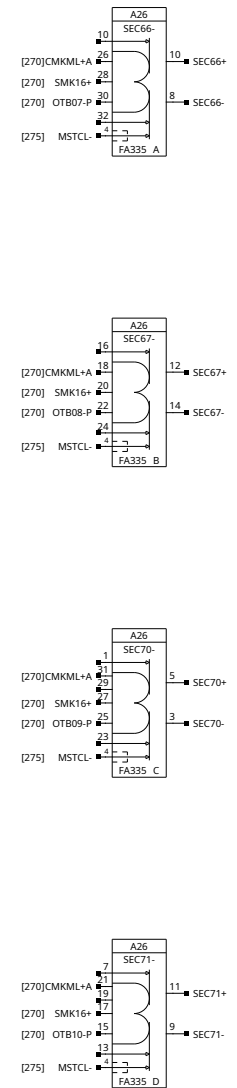
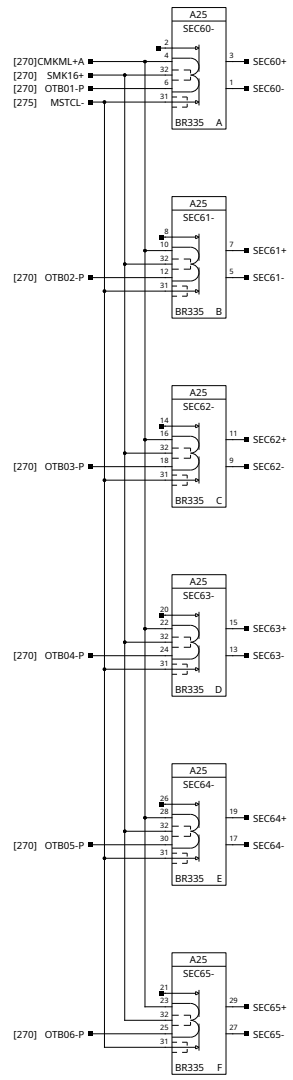

1
2
3
4
5
6
7
8
9
10
11
12

NOTES:
 ▲ ALL PACS THIS PAGE INCLUDED IF MORE THAN 24K OF MLO.
 ▲
 ▲
 ▲
 ▲

REV.	A
REVISIONS	
CHK.	S. R. 664

HONEYWELL
 INC
 COMPUTER CONTROL DIVISION
 Old Connecticut Path, Framingham, Mass

DR. D. HAMEL	DATE
ENG. K. ROY	11/4/69
APP.	11/5/69

PROJECT NO. 53218

TITLE
 H-316-08
 LOCKOUT MASK REGISTER #4

SIZE	DWG NO.	REV.
C	70027544	/

B18	
CNC18+	
[143] OTB09+	1
[*] INB10-	3
[143] ADB13-	5
[143] OTB11+	7
[*] INB12-	9
[143] ADB15-	11
[143] OTB13+	13
[*] INB14-	15
[*] PIL00-	17
[143] OTB15+	19
[*] INB16-	21
[*] PWRFL-	23
[143] CMKXX-	25
ENDOP-	27
[143] RRLIN-	29
[143] MSTCL-	31
	33
	34
CNC18	

C18	
CNC18+	
[143] OTB01+	1
[*] INB02-	3
[143] ADB08-	5
[143] OTB03+	7
[*] INB04-	9
[143] ADB10-	11
[143] OTB05+	13
[*] INB06-	15
[*] DRLIN-	17
[143] OTB07+	19
[*] INB08-	21
[*] SPARE+A	23
[143] SMKXX-	25
[143] OCPLS-	27
[143] SMK01-	29
[143] ERLXX-	31
	33
	34
CNC18	

B28	
CNC28+	
[143] OTB09+	1
[*] INB10-Q	3
[143] ADB13-Q	5
[143] OTB11-Q	7
[*] INB12-Q	9
[143] ADB15-Q	11
[143] OTB13-Q	13
[*] INB14-Q	15
[*] PIL00-Q	17
[143] INB15-Q	19
[*] INB16-Q	21
[*] PWRFL-Q	23
[143] CMKXX-Q	25
ENDOP-Q	27
[143] RRLIN-Q	29
[143] MSTCL-Q	31
	33
	34
CNC28	

SEE NOTE

B11	
CNC11+	
[143] OTB09+	1
[*] INB10-	3
[143] ADB13-	5
[143] OTB11+	7
[*] INB12-	9
[143] ADB15-	11
[143] OTB13+	13
[*] INB14-	15
[*] PIL00-	17
[143] OTB15+	19
[*] INB16-	21
[*] PWRFL-	23
[143] CMKXX-	25
ENDOP-	27
[143] RRLIN-	29
[143] MSTCL-	31
	33
	34
CNC11	

C11	
CNC11+	
[143] OTB01+	1
[*] INB02-	3
[143] ADB08-	5
[143] OTB03+	7
[*] INB04-	9
[143] ADB10-	11
[143] OTB05+	13
[*] INB06-	15
[*] DRLIN-	17
[143] OTB07+	19
[*] INB08-	21
[*] SPARE+A	23
[143] SMKXX-	25
[143] OCPLS-	27
[143] SMK01-	29
[143] ERLXX-	31
	33
	34
CNC11	

A18	
CNA18+	
SMK20-	1
BSD02+	3
D05FF-	5
D03FF-	7
D06FF-	9
D04FF-	11
D07FF-	13
PROTX+	15
	17
	18
	19
	20
	21
	22
	23
	24
	25
	26
	27
	28
	29
	30
	31
	32
	33
	34
CNA18	

B21	
CNC21+	
[143] OTB09+	1
[*] INB10-Q	3
[143] ADB13-Q	5
[143] OTB11-Q	7
[*] INB12-Q	9
[143] ADB15-Q	11
[143] OTB13-Q	13
[*] INB14-Q	15
[*] PIL00-Q	17
[143] INB15-Q	19
[*] INB16-Q	21
[*] PWRFL-Q	23
[143] CMKXX-Q	25
ENDOP-Q	27
[143] RRLIN-Q	29
[143] MSTCL-Q	31
	33
	34
CNC21	

C21	
CNC21+	
[143] OTB01+Q	1
[*] INB02-Q	3
[143] ADB08-Q	5
[143] OTB03+Q	7
[*] INB04-Q	9
[143] ADB09-Q	11
[143] OTB04+Q	13
[*] INB05-Q	15
[*] INB06-Q	17
[*] DRLIN-Q	19
[143] OTB07+Q	21
[*] INB08-Q	23
[*] SPARE+R	25
[143] SMKXX-Q	27
[143] OCPLS-Q	29
[143] SMK01-Q	31
[143] ERLXX-Q	33
	34
CNC21	

SEE NOTE

NOTES-

- INCLUDED IF MORE THAN 16K MLO.
- [*] THESE SIGNALS ARRIVE BY BUS FROM I/O OPTIONS, DEPENDING ON SYSTEM CONFIGURATION.
- THESE SIGNALS ARRIVE FROM H-316-21 HSDMC.
- THESE SIGNALS ARE CONNECTED TO SLOT C16 OF THE CPU MAINFRAME BY MEANS OF A TWISTED PAIR CABLE.

REV.	DESCRIPTION
A	

S. R. 664-4192

HONEYWELL
INC.
COMPUTER CONTROL DIVISION
Old Connecticut Path, Framingham, Mass

DR. D. HAMEL	DATE
ENG. K. ROY	11/4/69
APP.	11/5/69

PROJECT NO. 53218

TITLE	H-316-08
	ML EXTERNAL CABLES
SIZE	DWG NO.
C	70027545
REV.	/